

XtraDrive (XD-) SERIES

AC Servo Driver

USER'S MANUAL

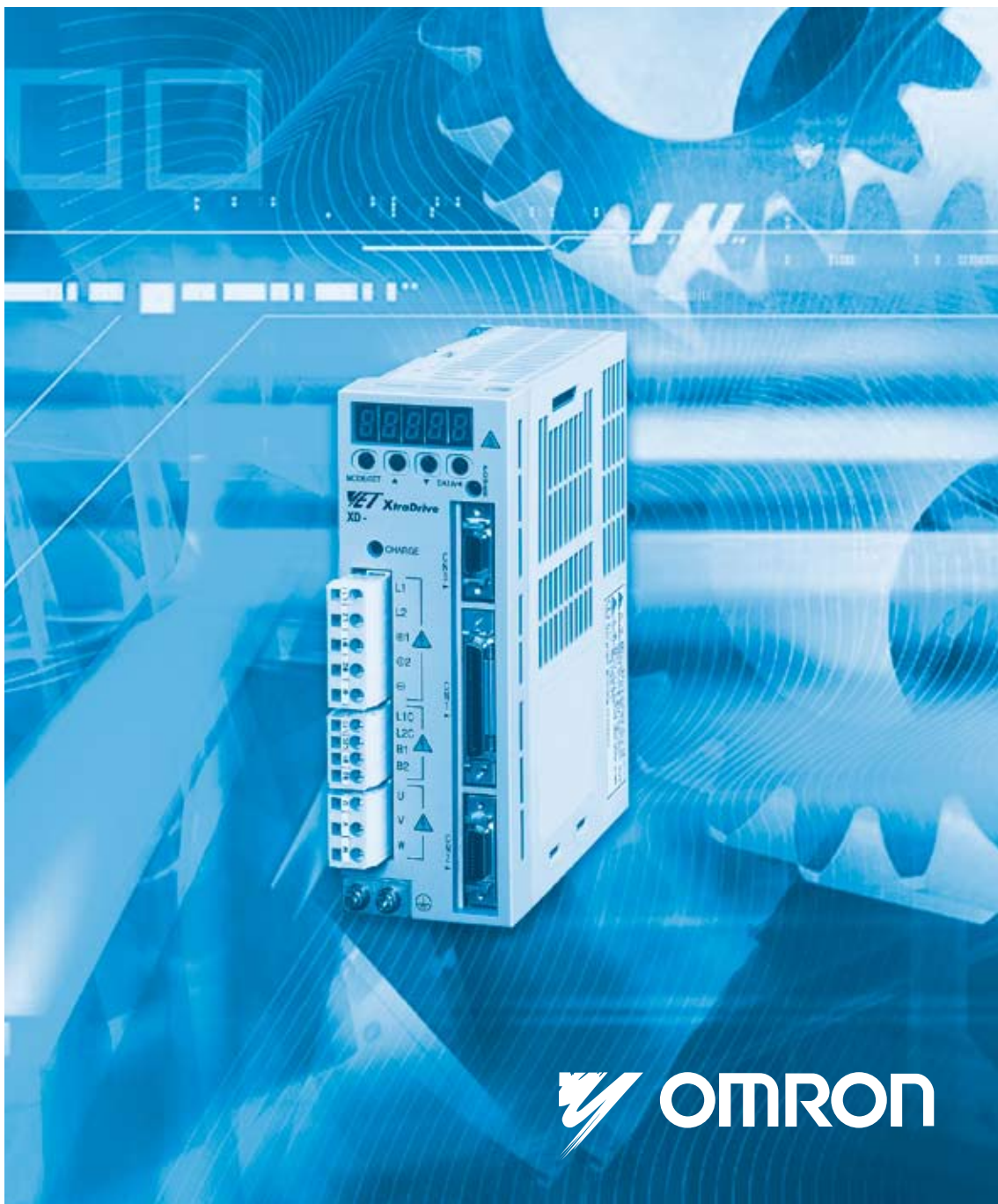

Copyright © 2003 by YET, Yaskawa Eshed Technology Ltd.

XtraDrive User Manual

Catalog No.8U0108, Revision C

November 2003

All rights reserved. No part of this publication may be stored in a retrieval system, or reproduced in any way, including but not limited to photocopy, photography, magnetic or other recording, without the prior agreement and written permission of the publisher. Program listings may be entered, stored and executed in a computer system, but not reproduced for publication.

This guide is designed to provide information about the XtraDrive hardware. Every effort has been made to make this guide complete and as accurate as possible. However, no warranty of suitability, purpose or fitness is made or implied. YET Ltd. is not liable or responsible to any person or entity for loss or damage in connection with or stemming from the use of **XtraDrive** and/or the information contained in this publication

YET Ltd. bears no responsibility for errors, which may appear in this publication and retains the right to make changes to the products and the guide without prior notice.

YET Ltd. ISRAEL

13 Hamelacha St.,
Afeq Industrial Estate
Rosh Ha'ayin 48091
ISRAEL

Tel: +972-3-9004114

Fax: +972-3-9030412

info@yetmotion.com

YET US Inc.

531 King St.,
Unit 1
Littleton, MA 01460
USA

Tel: +1-866-YET-8080

Fax: +1-978-952-6821

USinfo@yetmotion.com

web site: **www.yetmotion.com**

WARNING

YET manufactures component parts that can be used in a wide variety of industrial applications. The selection and application of YET products remain the responsibility of the equipment designer or end user. YET accepts no responsibility for the way its products are incorporated into the final system design.

Under no circumstances should any YET product be incorporated into any product or design as the exclusive or sole safety control. Without exception, all controls should be designed to detect faults dynamically and fail safely under all circumstances. All products designed to incorporate a component part manufactured by YET must be supplied to the end user with appropriate warnings and instructions as to that part's safe use and operation. Any warnings provided by YET must be promptly provided to the end user.

YET offers an express warranty only as to the quality of its products in conforming to standards and specifications published in YET's manual. **NO OTHER WARRANTY, EXPRESS OR IMPLIED, IS OFFERED.** YET assumes no liability for any personal injury, property damage, losses, or claims arising from misapplication of its products.

This page intentionally left blank.

Safety Information

The following defines the symbols used in this manual to indicate varying degrees of safety precautions and to identify the corresponding level of hazard inherent to each. Failure to follow precautions provided in this manual can result in serious, possibly even fatal, injury, and/or damage to the persons, products, or related equipment and systems.

WARNING

- **WARNING:** Indicates a potentially hazardous situation, which, if not heeded, could result in death or serious injury.

CAUTION

- **CAUTION:** Indicates a potentially hazardous situation, which, if not avoided, may result in minor or moderate injury.

This page intentionally left blank.

Table of Contents

1. Checking Product and Part Names	1-1
1.1. Checking the XtraDrive Series Products on Delivery	1-2
1.1.1. Servo Amplifiers	1-2
1.2. Product Part Names	1-3
1.2.1. Servo Amplifiers	1-3
1.2.2. Model Numbers	1-4
2. Installation	2-1
2.1. Servo Amplifiers	2-2
2.1.1. Storage Conditions	2-2
2.1.2. Installation Site	2-2
2.1.3. Orientation	2-3
2.1.4. Installation	2-3
3. Wiring	3-1
3.1. Connecting to Peripheral Devices	3-2
3.1.1. Single-Phase 200V Main Circuit Specifications	3-3
3.1.2. Single-Phase 0.8kW 200V Main Circuit Specifications	3-4
3.1.3. Three-phase 200V Main Circuit Specifications	3-5
3.1.4. Three-Phase 400V Main Circuit Specifications	3-6
3.2. XtraDrive Internal Block Diagrams	3-7
3.2.1. Single-phase 30W to 800W, 200V Models	3-7
3.2.2. Three-phase 1kW to 3kW, 200V Models	3-8
3.2.3. Three-phase 0.5kW to 3.0kW, 400V Models	3-9
3.3. Main Circuit Wiring	3-10
3.3.1. Names and Descriptions of Main Circuit Terminal	3-11
3.3.2. Typical Main Circuit Wiring Example	3-12
3.3.3. Servo Amplifier Power Losses	3-13
3.3.4. Wiring Main Circuit Terminal Blocks	3-14
3.4. I/O Signals	3-15
3.4.1. Example of Typical I/O Signal Connections	3-15
3.4.2. List of CN1 Terminals	3-16
3.4.3. I/O Signal Names and Functions	3-17
3.4.4. Interface Circuits	3-19
3.5. Wiring Encoders (for SGMGH and SGMSH Motors Only)	3-23
3.5.1. Encoder Connections	3-23
3.5.2. CN2 Encoder Connector Terminal Layout and Types	3-25
3.5.3. Encoder Cables Interconnections	3-26
3.6. Examples of Standard Connections	3-28
4. Trial Operation	4-1
4.1. Two-Step Trial Operation	4-2
4.1.1. Step 1: Trial Operation for Servomotor without Load	4-3
4.1.2. Step 2: Trial Operation with Servomotor Connected to Machine	4-9
4.2. Additional Setup Procedures in Trial Operation	4-10
4.2.1. Servomotors with Brakes	4-10
4.2.2. Position Control by Host Controller	4-11
4.3. Minimum Parameters and Input Signals	4-12
4.3.1. Parameters	4-12
4.3.2. Input Signals	4-12

5.	Parameter Settings and Functions	5-1
5.1.	Settings According to Device Characteristics	5-4
5.1.1.	Switching Servomotor Rotation Direction.....	5-4
5.1.2.	Setting the Overtravel Limit Function	5-5
5.1.3.	Limiting Torque.....	5-8
5.2.	Settings According to Host Controller.....	5-12
5.2.1.	Speed Reference	5-12
5.2.2.	Position Reference	5-14
5.2.3.	Using the Encoder Signal Output.....	5-20
5.2.4.	Sequence I/O Signals.....	5-23
5.2.5.	Using the Electronic Gear Function.....	5-25
5.2.6.	Contact Input Speed Control	5-29
5.2.7.	Using Torque Control.....	5-34
5.2.8.	Torque Feed-Forward Function	5-40
5.2.9.	Torque Limiting by Analog Voltage Reference	5-42
5.2.10.	Reference Pulse Inhibit Function (/INHIBIT)	5-44
5.3.	Setting Up the Servo Amplifier	5-45
5.3.1.	Parameters.....	5-45
5.3.2.	JOG Speed	5-46
5.3.3.	Input Circuit Signal Allocation	5-46
5.3.4.	Output Circuit Signal Allocation.....	5-50
5.3.5.	Control Mode Selection.....	5-52
5.4.	Setting Stop Functions	5-54
5.4.1.	Adjusting Offset.....	5-54
5.4.2.	Servo OFF Stop Mode Selection.....	5-55
5.4.3.	Using the Zero Clamp Function	5-56
5.4.4.	Using the Holding Brake	5-58
5.5.	Forming a Protective Sequence	5-61
5.5.1.	Using Servo Alarm and Alarm Code Outputs	5-61
5.5.2.	Using the Servo ON Input Signal (/S-ON)	5-63
5.5.3.	Using the Positioning Completed Output Signal (/COIN).....	5-64
5.5.4.	Speed Coincidence Output (/V-CMP)	5-65
5.5.5.	Using the Running Output Signal (/TGON).....	5-67
5.5.6.	Using the Servo Ready Output Signal (/S-RDY).....	5-68
5.5.7.	Using the Warning Output Signal (/WARN).....	5-69
5.5.8.	Handling Power Loss.....	5-71
5.6.	Selecting a Regenerative Resistor.....	5-72
5.6.1.	External Regenerative Resistor	5-73
5.6.2.	Calculating the Regenerative Power Capacity.....	5-74
5.7.	Absolute Encoders.....	5-78
5.7.1.	Interface Circuit	5-79
5.7.2.	Configuring an Absolute Encoder.....	5-80
5.7.3.	Absolute Encoder Setup	5-81
5.7.4.	Absolute Encoder Reception Sequence	5-84
5.8.	AB Encoders.....	5-89
5.9.	Configuration of Serial Commands for AB Encoders	5-91
5.9.1.	Position Control	5-91
5.9.1.1.	Defining User Units for Motion Profiles	5-91
5.9.1.2.	Position Units.....	5-91
5.9.1.3.	Speed Units	5-92

5.9.1.4.	Acceleration Units	5-93
5.9.1.5.	Setting Default Motion Profile Parameters	5-94
5.9.1.6.	Profile Speed (Pn2A2, Pn2A3)	5-95
5.9.1.7.	Profile Acceleration (Pn2A4, Pn2A5).....	5-95
5.9.1.8.	Jerk Smoothing Time (Pn2A6)	5-95
5.9.1.9.	Quick Stop Deceleration (Pn2A8, Pn2A9)	5-96
5.9.1.10.	Motion End Window (Pn2C0)	5-96
5.9.2.	Torque Control.....	5-96
5.9.2.1.	Torque Slope (Pn2C1)	5-96
5.9.3.	Homing.....	5-97
5.9.4.	Digital I/O	5-98
5.9.5.	Auto Tuning.....	5-99
5.10.	Auto Running a User Program.....	5-99
6.	Servo Adjustment.....	6-1
6.1.	Selection of Control Mode.....	6-2
6.2.	Analog Input or Contact Input Velocity Control.....	6-3
6.2.1.	Principle and Block Diagram of the Velocity Control	6-3
6.2.2.	Parameters of the Velocity Control	6-4
6.2.3.	Setting the Input Gain	6-4
6.2.4.	Adjusting Offset.....	6-5
6.2.5.	Using the Soft Start Function	6-6
6.2.6.	Load Inertia Setting.....	6-7
6.2.7.	Adjusting Speed Loop Gain	6-8
6.2.8.	Setting the Torque Reference Filter Time Constant	6-9
6.2.9.	Notch Filter	6-9
6.2.10.	Gain Setting Reference Values.....	6-10
6.3.	NCT Position Control.....	6-12
6.3.1.	Load Inertia Setting.....	6-12
6.3.2.	Position Control Block Diagram	6-14
6.3.3.	NCT Gain Parameters.....	6-15
6.3.4.	OCA - Oscillation Canceling Algorithm	6-16
6.3.5.	Additional Parameters Tuning.....	6-17
6.3.6.	Filters.....	6-17
6.3.7.	Flexible System Parameters	6-18
6.3.8.	Gain Factor.....	6-19
6.3.9.	Integral Clear Parameters	6-19
6.3.10.	Tuning Procedure for Position Control Parameters.....	6-20
6.4.	Analog Monitor	6-22
7.	Using the Panel Operator	7-1
7.1.	Basic Operation	7-2
7.1.1.	Panel Operator	7-2
7.1.2.	Resetting Servo Alarms	7-3
7.1.3.	Basic Mode Selection	7-3
7.1.4.	Status Display Mode.....	7-4
7.1.5.	Operation in Parameter Setting Mode.....	7-6
7.1.6.	Operation in Monitor Mode	7-11
7.2.	Applied Operation.....	7-16
7.2.1.	Operation in Alarm Traceback Mode	7-17
7.2.2.	JOG Operation	7-18
7.2.3.	Automatic Adjustment of Speed and Torque Reference Offset.....	7-20

7.2.4.	Manual Adjustment of Speed and Torque Reference Offset	7-22
7.2.5.	Clearing Alarm Traceback Data.....	7-25
7.2.6.	Checking the Motor Model	7-26
7.2.7.	Checking the Software Version.....	7-27
7.2.8.	Origin Search Mode.....	7-28
7.2.9.	Initializing Parameter Settings.....	7-30
7.2.10.	Manual Zero Adjustment and Gain Adjustment of Analog Monitor Output 7-31	
7.2.11.	Adjusting the Motor Current Detection Offset	7-34
7.2.12.	Write Protection Setting	7-36
7.2.13.	Clearing the Option Unit Detection Alarm	7-37
8.	Ratings, Specifications and Dimensional Drawings.....	8-1
8.1.	Ratings and Specifications	8-2
8.2.	Single-phase 200V XtraDrive and Motors Combinations	8-6
8.3.	Three-phase 200V XtraDrive and Motor Combinations.....	8-7
8.4.	Three-phase 400V XtraDrive and Motors Combinations	8-8
8.5.	Base-mounted Dimensional Drawings	8-10
8.5.1.	XD-P3 to -02 (1-phase 200V, 30 to 200 W).....	8-10
8.5.2.	XD-04 (1-phase 200 V, 400 W).....	8-11
8.5.3.	XD-08 (1-phase 200V, 0.75kW) and XD-10 (3-phase 200V, 1.0kW).....	8-12
8.5.4.	XD-05, 10, 15 (3-phase 400V, 0.5 to 1.5kW)	8-13
8.5.5.	XD-20, -30 (3-phase 200V,400V, 2.0 and 3.0 kW)	8-14
8.6.	Rack-mounted Dimensional Drawings.....	8-15
8.6.1.	XD-P3 to -02 (1-phase 200V, 30 to 200 W).....	8-15
8.6.2.	XD-04 (1-phase 200 V, 400 W).....	8-16
8.6.3.	XD-08 (1-phase 200V, 0.75kW) and XD-10 (3-phase 200V, 1.0kW).....	8-17
8.6.4.	XD-05, 10, 15 (3-phase 400V, 0.5 to 1.5kW)	8-18
8.6.5.	XD-20, -30 (3-phase 200V,400V, 2.0 and 3.0 kW)	8-19
9.	Inspection, Maintenance, and Troubleshooting.....	9-1
9.1.	XtraDrive Inspection and Maintenance	9-2
9.1.1.	Servomotor Inspection.....	9-2
9.1.2.	Servo Amplifier Inspection	9-2
9.1.3.	Replacing the Battery for the Absolute Encoder	9-3
9.2.	Troubleshooting.....	9-4
9.2.1.	Troubleshooting Problems with Alarm Displays	9-4
9.2.2.	Troubleshooting Problems with No Alarm Display	9-25
9.2.3.	Alarm Display Table.....	9-26
9.2.4.	Warning Displays	9-28
Appendix A.	Host Controller Connection Examples	A-1
A.1.	Connecting the GL-series MC20 Motion Module	A-2
A.2.	Connecting the CP-9200SH Servo Controller Module (SVA).....	A-3
A.3.	Connecting the GL-series B2813 Positioning Module	A-4
A.4.	Connecting OMRON's C500-NC222 Position Control Unit.....	A-5
A.5.	Connecting OMRON's C500-NC112 Position Control Unit.....	A-6
A.6.	Connecting MITSUBISHI's AD72 Positioning Unit	A-7
A.7.	Connecting MITSUBISHI's AD75 Positioning Unit	A-8
Appendix B.	Special Wiring	B-1
B.1.	Wiring Precautions	B-2
B.2.	Wiring for Noise Control	B-5
B.3.	Using More Than One XtraDrive	B-9

B.4.	Extending Encoder Cables	B-10
B.5.	400V Power Supply Voltage	B-12
B.6.	Reactor for Harmonic Suppression.....	B-14
Appendix C. Specifications for Peripheral Devices.....		C-1
C.1.	Connector Terminal Block Converter Unit JUSP-TA50P.....	C-2
C.2.	External Regenerative Resistors	C-4
C.3.	DC Reactors for Power Supplies Designed for Minimum Harmonics.....	C-6
C.4.	Brake Power Supplies	C-8
C.5.	Surge Suppressor.....	C-9
C.6.	Magnetic Contactor	C-9
C.7.	Variable Resistor for Speed Setting.....	C-9
C.8.	CN1 I/O Signal Connector.....	C-9
C.9.	Connecting Pulse A/B Encoder without C Pulse (Index Pulse)	C-10
C.10.	Absolute Encoder Battery	C-11
C.11.	Cables for Connecting PC to XtraDrive	C-12
C.11.1.	RS-232 Communication Cable	C-12
C.11.2.	Cable with RS-232 to RS-422 Active Adapter.....	C-14
C.12.	Connecting Regenerative Resistors	C-15
C.13.	Connecting Yaskawa Option Board	C-19
C.13.1.	Attaching the Option Board	C-19
C.13.2.	Detaching the Option Board.....	C-19
Appendix D. List of Parameters.....		D-1
D.1.	Parameters	D-2
D.2.	Switches.....	D-7
D.3.	Input Signal Selections.....	D-11
D.3.1.	Home Switches	D-12
D.3.2.	Extended input signal selection.....	D-12
D.4.	Output Signal Selections	D-13
D.4.1.	Extended Output Signal Selection	D-13
D.5.	Auxiliary Functions.....	D-14
D.6.	Monitor Modes	D-14

This page intentionally left blank.

Using This Manual

■ Intended Audience

This manual is intended for the following users.

- Those designing XtraDrive XD-□ Series servodrive systems.
- Those installing or wiring XtraDrive XD-□ Series servodrives.
- Those performing trial operation or adjustments of XtraDrive XD-□ Series servodrives.
- Those maintaining or inspecting XtraDrive XD-□ Series servodrives.

■ Description of Technical Terms

In this manual, the following terms are defined as follows:

- **Servomotor** = SGMAH/SGMPH/SGMGH/SGMSH or other compatible servomotor.
- **Servo Amplifier** = XtraDrive Series XD-□ servo amplifier.
- **Servodrive** = A set including a servomotor and servo amplifier.
- **Servo System** = A servo control system that includes the combination of a servodrive with a host computer and peripheral devices.

■ Indication of Inverted Signals

In this manual, the names of inverted signals (ones that are valid when low) are written with a forward slash (/) before the signal name, as shown in the following equations:

- $\overline{\text{S-ON}} = /\text{S-ON}$
- $\overline{\text{P-CON}} = /\text{P-CON}$

Safety Precautions

The following precautions are for checking products upon delivery, installation, wiring, operation, maintenance and inspections.

■ Checking Products upon Delivery

CAUTION

- **Always use the servomotor and servo amplifier in one of the specified combinations.**
Not doing so may cause fire or malfunction.

■ Installation

CAUTION

- **Never use the products in an environment subject to water, corrosive gases, inflammable gases, or combustibles.**
Doing so may result in electric shock or fire.

■ Wiring

WARNING

- **Connect the ground terminal to a class 3 ground (100. or less).**
Improper grounding may result in electric shock or fire.

CAUTION

- **Do not connect a three-phase power supply to the U, V, or W output terminals.**
Doing so may result in injury or fire.
- **Securely fasten the power supply terminal screws and motor output terminal screws.**
Not doing so may result in fire.

■ Operation

CAUTION

- **Never touch any rotating motor parts while the motor is running.**
Doing so may result in injury.

CAUTION

- **Conduct trial operation on the servomotor alone with the motor shaft disconnected from machine to avoid any unexpected accidents.**
Not doing so may result in injury.
- **Before starting operation with a machine connected, change the settings to match the parameters of the machine.**
Starting operation without matching the proper settings may cause the machine to run out of control or malfunction.
- **Before starting operation with a machine connected, make sure that an emergency stop can be applied at any time.**
Not doing so may result in injury.
- **Do not touch the heat sinks during operation.**
Not doing so may result in burns due to high temperatures.

■ Maintenance and Inspection

WARNING

- **Do not remove the panel cover while the power is ON.**
Doing so carries a risk of electric shock.
- **Do not touch terminals for five minutes after the power has been turned OFF.**
Residual voltage may cause electric shock.
- **Never touch the inside of the servo amplifier.**
Doing so may result in electric shock.

CAUTION

- **Do not disassemble the servomotor.**
Doing so may result in electric shock or injury
- **Do not attempt to change wiring while the power is ON.**
Doing so may result in electric shock or injury

■ General Precautions

NOTE THE FOLLOWING TO ENSURE SAFE APPLICATION:

- The drawings presented in this manual are sometimes shown without covers or protective guards. Always replace the cover or protective guard as specified first, and then operate the products in accordance with the manual.
- The drawings presented in this manual are typical examples and may not match the product you received.
- This manual is subject to change due to product improvement, specification modification, and manual improvement. When this manual is revised, the manual code is updated, and the new manual is published as a next edition. The edition number appears on the front and back covers.
- If the manual must be ordered due to loss or damage, inform your nearest YET representative or one of the offices listed on the back of this manual.
- YET will not take responsibility for the results of unauthorized modifications of this product. YET shall not be liable for any damages or troubles resulting from unauthorized modification.

1. Checking Product and Part Names

This chapter describes the procedure for checking products upon delivery as well as names for product parts.

1. Checking Product and Part Names	1-1
1.1. Checking the XtraDrive Series Products on Delivery	1-2
1.1.1. Servo Amplifiers	1-2
1.2. Product Part Names.....	1-3
1.2.1. Servo Amplifiers	1-3
1.2.2. Model Numbers	1-4

1.1. Checking the XtraDrive Series Products on Delivery

The following procedure is suggested to check XtraDrive series products upon delivery.

Use the following checklist when XtraDrive series products are delivered.

Initial Inspection	Comments
Are the delivered products the ones that were ordered?	Check the model numbers marked on the nameplates of the servomotor and servo amplifier. (Refer to the descriptions of model numbers on following pages)
Does the servomotor shaft rotate smoothly?	The servomotor shaft is normal if it can be turned smoothly by hand. Servomotors with brakes, however, cannot be turned manually.
Is there any damage?	Check the overall appearance, and check for damage or scratches that may have occurred during shipping.
Are there any loose screws?	Check screws for looseness using a screwdriver.

If any of the above are faulty or incorrect, contact YET or an authorized distributor.

1.1.1. Servo Amplifiers

■ External Appearance and Nameplate Examples

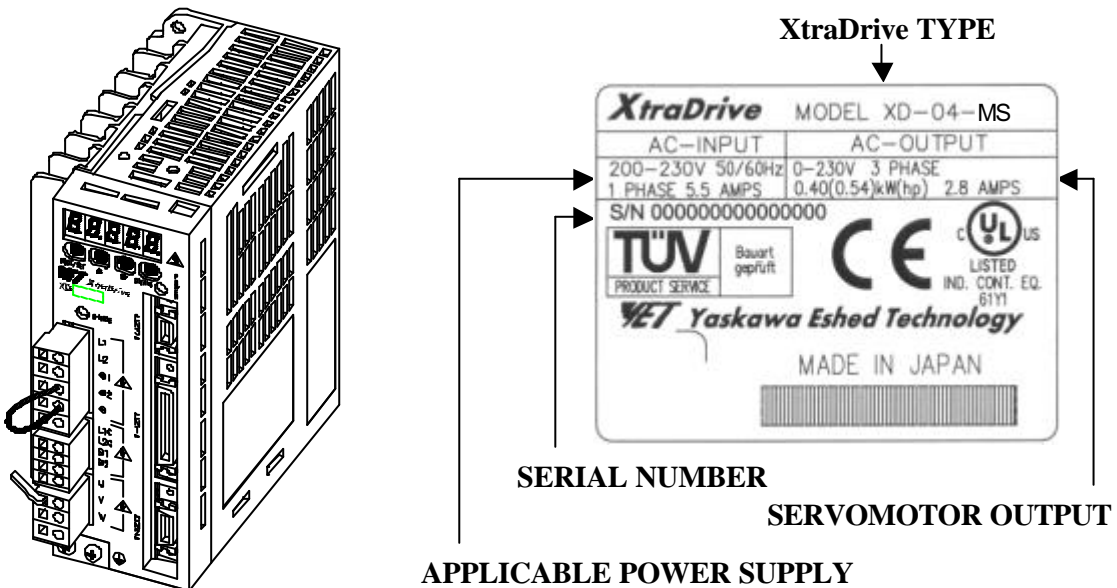

1.2. Product Part Names

This section describes product part names.

1.2.1. Servo Amplifiers

The figure below shows the part names for servo amplifiers.

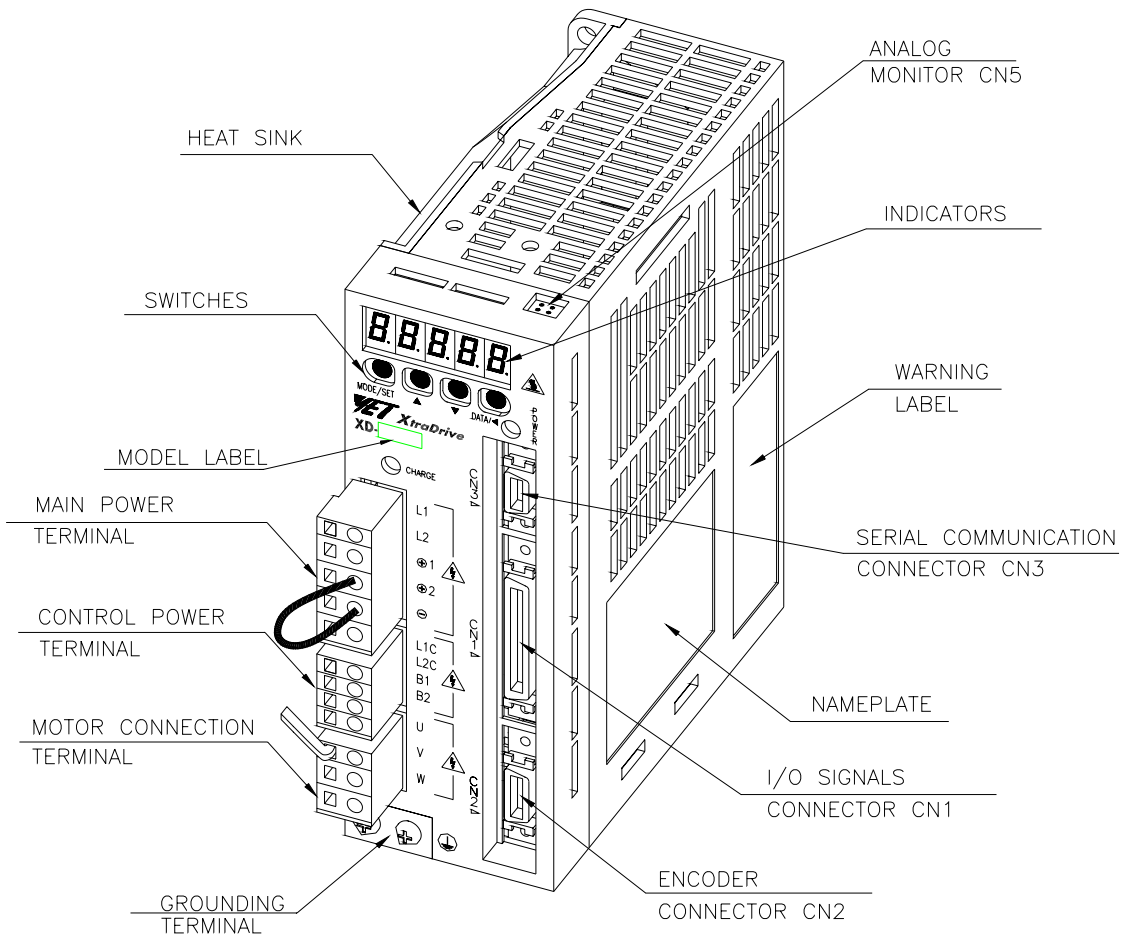

1.2.2. Model Numbers

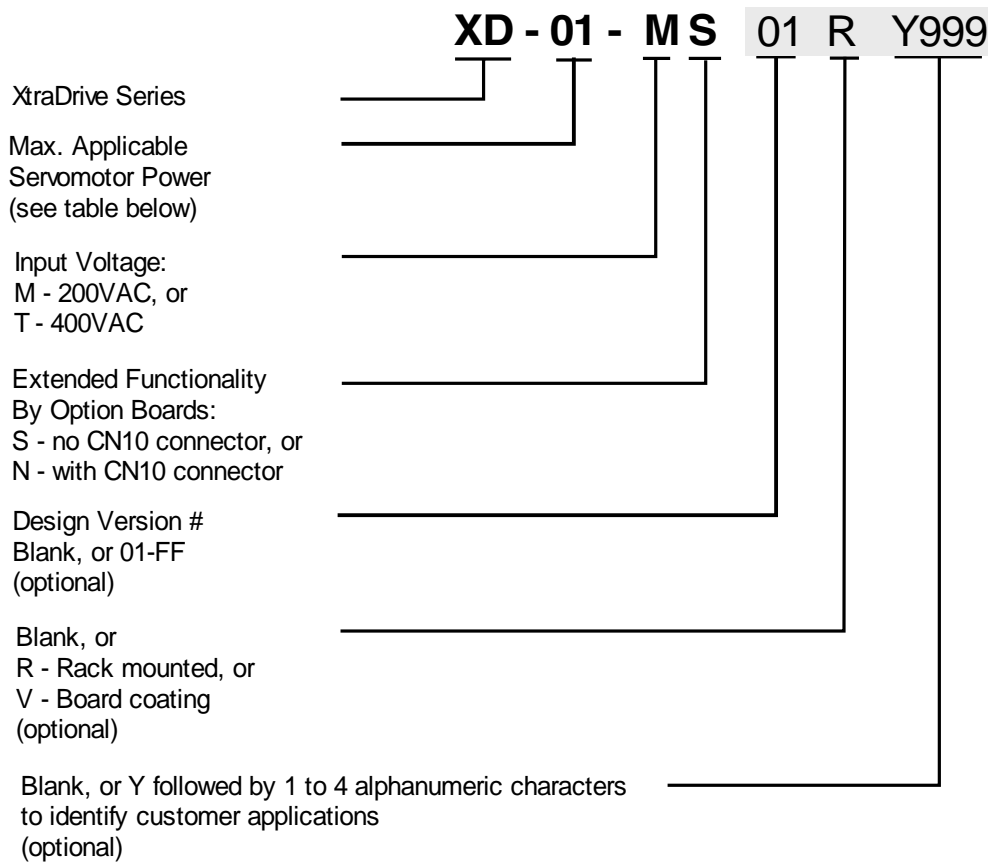

Output Capacity Code	Max. Applicable Servomotor Power (kW)	Output Capacity Code	Max. Applicable Servomotor Power (kW)
P3	0.03	08	0.75
P5	0.05	10	1.0
01	0.10	15	1.5
02	0.20	20	2.0
04	0.40	30	3.0

2. Installation

This chapter describes precautions for XtraDrive Series servomotor and servo amplifier installation.

2.1.	Servo Amplifiers	2-2
2.1.1.	Storage Conditions	2-2
2.1.2.	Installation Site	2-2
2.1.3.	Orientation	2-3
2.1.4.	Installation.....	2-3

2.1. Servo Amplifiers

The XtraDrive servo amplifiers are base-mounted. Incorrect installation will cause problems. Follow the installation instructions below.

2.1.1. Storage Conditions

Store the servo amplifier within the following temperature range, as long as it is stored with the power cable disconnected.

-20 to 85°C

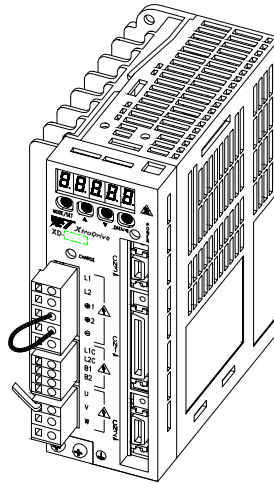

2.1.2. Installation Site

The following precautions apply to the installation site.

Situation	Installation Precaution
Installation in a Control Panel	Design the control panel size, unit layout, and cooling method so the temperature around the servo amplifier does not exceed 55°C.
Installation Near a Heating Unit	Minimize heat radiated from the heating unit as well as any temperature rise caused by natural convection so the temperature around the servo amplifier does not exceed 55°C.
Installation Near a Source of Vibration	Install a vibration isolator beneath the servo amplifier to avoid subjecting it to vibration.
Installation at a Site Exposed to Corrosive Gas	Corrosive gas does not have an immediate effect on the servo amplifier, but will eventually cause electronic components and contactor-related devices to malfunction. Take appropriate action to avoid corrosive gas.
Other Situations	Do not install the servo amplifier in hot and humid locations or locations subject to excessive dust or iron powder in the air.

2.1.3. Orientation

Install the servo amplifier perpendicular to the wall as shown in the figure. The servo amplifier must be oriented this way because it is designed to be cooled by natural convection or by a cooling fan.

Secure the servo amplifier using the mounting holes. The number of holes varies (from two to four) with the frame size of the servo amplifier.

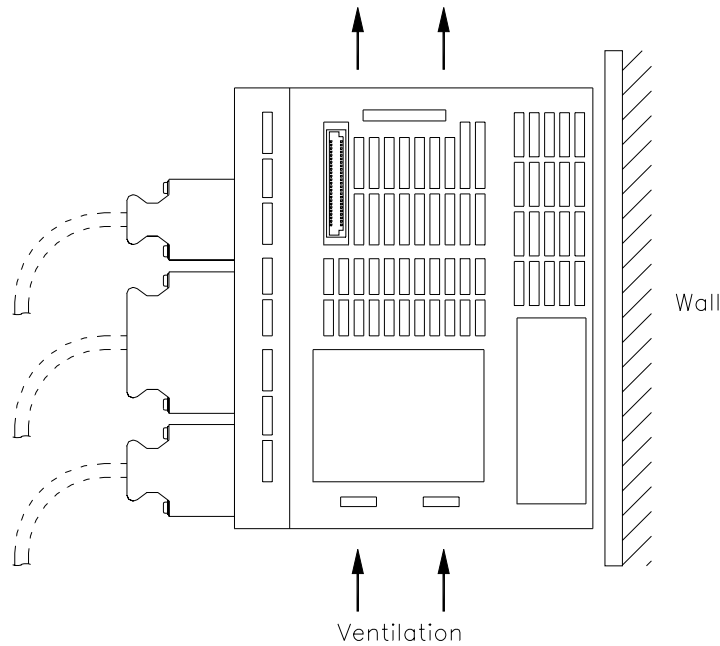

2.1.4. Installation

Follow the procedure below to install multiple servo amplifiers side by side in a control panel.

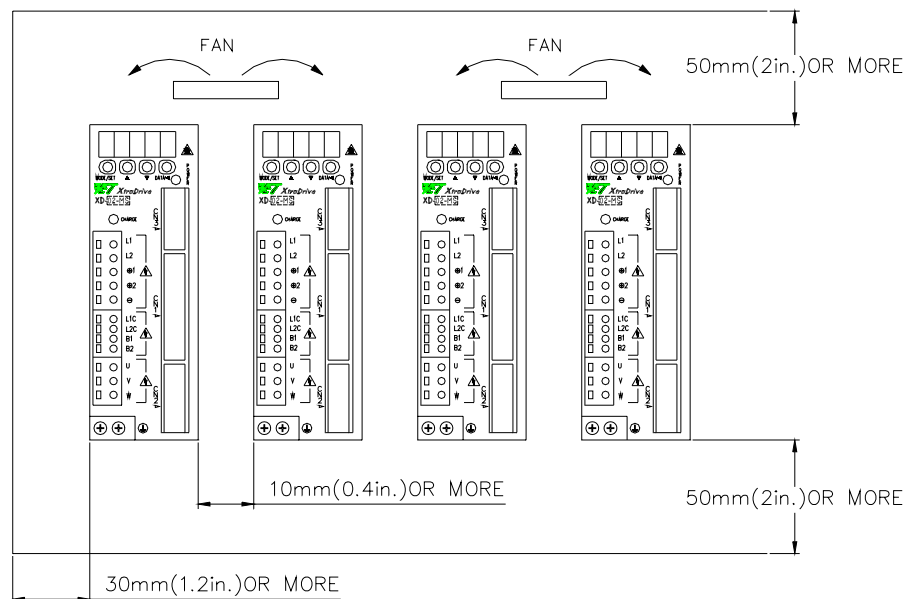

■ **Servo Amplifier Orientation**

Install the servo amplifier perpendicular to the wall so the front panels' connectors faces outward.

■ **Cooling**

As shown in the figure above, allow sufficient space around each servo amplifier for cooling by cooling fans or natural convection.

■ **Side-by-side Installation**

When installing servo amplifiers side by side as shown in the figure above, allow at least 0.39in (10mm) between and at least 1.97in (50mm) above and below each servo amplifier. Install cooling fans above the servo amplifiers to avoid excessive temperature rise and to maintain even temperature inside the control panel.

■ **Environmental Conditions in the Control Panel**

- Ambient Temperature: 0 to 55°C
- Humidity: 90% RH or less
- Vibration: 0.5 G (4.9m/s²)
- Condensation and Freezing: None
- Ambient Temperature for Long-term Reliability: 45°C max.

3. Wiring

This chapter describes the procedure used to connect XtraDrive Series products to peripheral devices and gives typical examples of main circuit wiring as well as I/O signal connections.

3.1.	Connecting to Peripheral Devices.....	3-2
3.1.1.	Single-Phase 200V Main Circuit Specifications.....	3-3
3.1.2.	Single-Phase 0.8kW 200V Main Circuit Specifications.....	3-4
3.1.3.	Three-phase 200V Main Circuit Specifications.....	3-5
3.1.4.	Three-Phase 400V Main Circuit Specifications	3-6
3.2.	XtraDrive Internal Block Diagrams.....	3-7
3.2.1.	Single-phase 30W to 800W, 200V Models	3-7
3.2.2.	Three-phase 1kW to 3kW, 200V Models	3-8
3.2.3.	Three-phase 0.5kW to 3.0kW, 400V Models	3-9
3.3.	Main Circuit Wiring.....	3-10
3.3.1.	Names and Descriptions of Main Circuit Terminal.....	3-11
3.3.2.	Typical Main Circuit Wiring Example	3-12
3.3.3.	Servo Amplifier Power Losses	3-13
3.3.4.	Wiring Main Circuit Terminal Blocks.....	3-14
3.4.	I/O Signals	3-15
3.4.1.	Example of Typical I/O Signal Connections	3-15
3.4.2.	List of CN1 Terminals	3-16
3.4.3.	I/O Signal Names and Functions	3-17
3.4.4.	Interface Circuits.....	3-19
3.5.	Wiring Encoders (for SGMGH and SGMSH Motors Only)	3-23
3.5.1.	Encoder Connections	3-23
3.5.2.	CN2 Encoder Connector Terminal Layout and Types	3-25
3.5.3.	Encoder Cables Interconnections.....	3-26
3.6.	Examples of Standard Connections	3-28

3.1. Connecting to Peripheral Devices

This section provides examples of standard XtraDrive Series product connections to peripheral devices.

It also briefly explains how to connect each peripheral device.

3.1.1. Single-Phase 200V Main Circuit Specifications

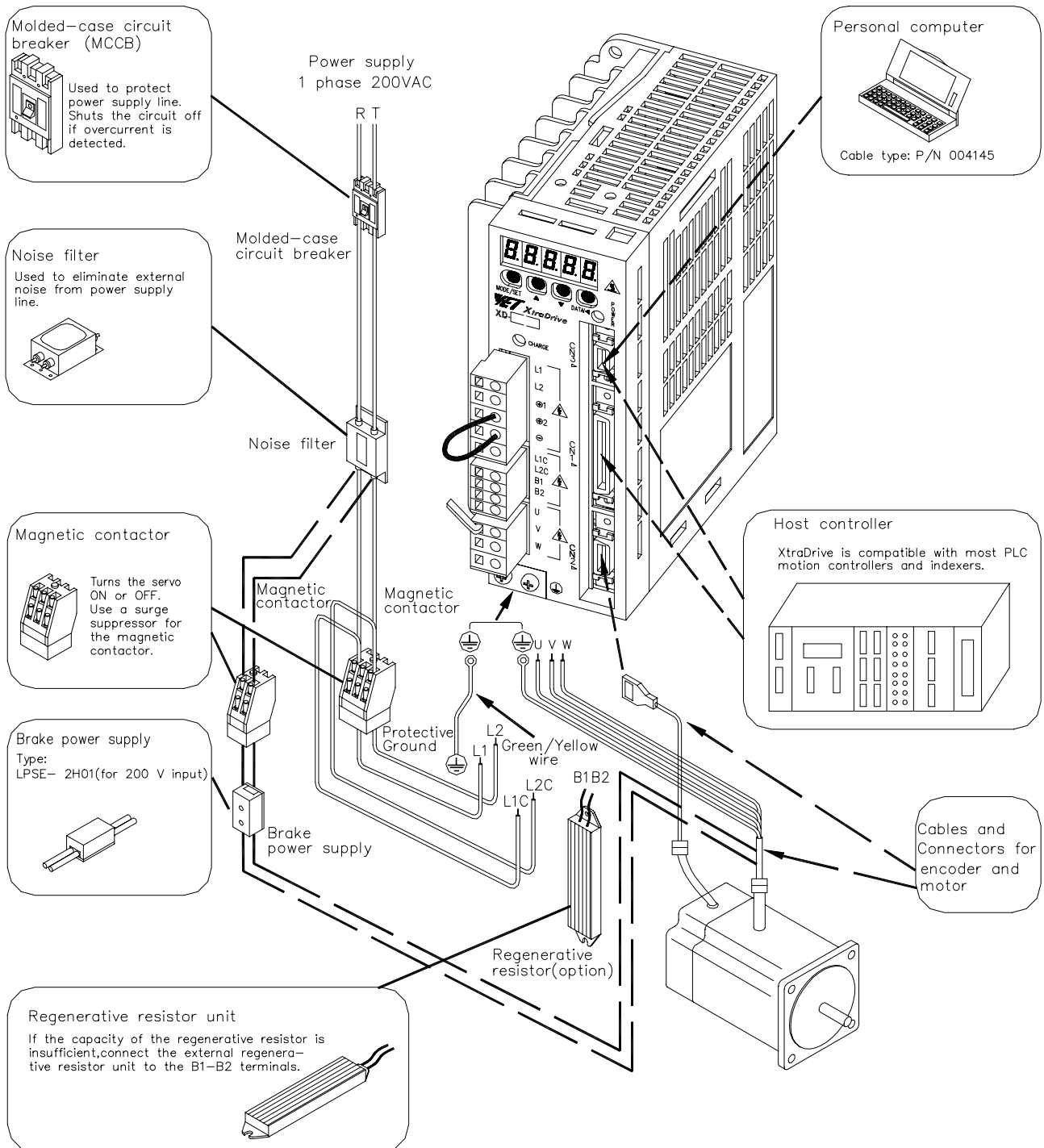

3.1.2. Single-Phase 0.8kW 200V Main Circuit Specifications

XtraDrive XD-08-MS has been changed from three-phase specifications to single-phase. Main circuit connection terminals (**L1**, **L2**, **L3**) remained.

These devices have terminal **B3** and internal regenerative resistor. Observe the following points.

1. Connect main power supply shown below to **L1** and **L3** terminals. Power supply is single-phase, 220 to 230 VAC +10% to -15%, 50/60Hz. If power supply of 187V (-15% of 220V) or less is used, alarm A.41 indicating voltage shortage, may occur when accelerating to max speed with max torque of motor.
2. Short-circuit **B2** and **B3** terminals using the internal regenerative resistor. If capacity of the regenerative resistor is insufficient, remove the lead between **B2** and **B3** terminals and connect an external regenerative resistor unit to **B1** and **B2** terminals.

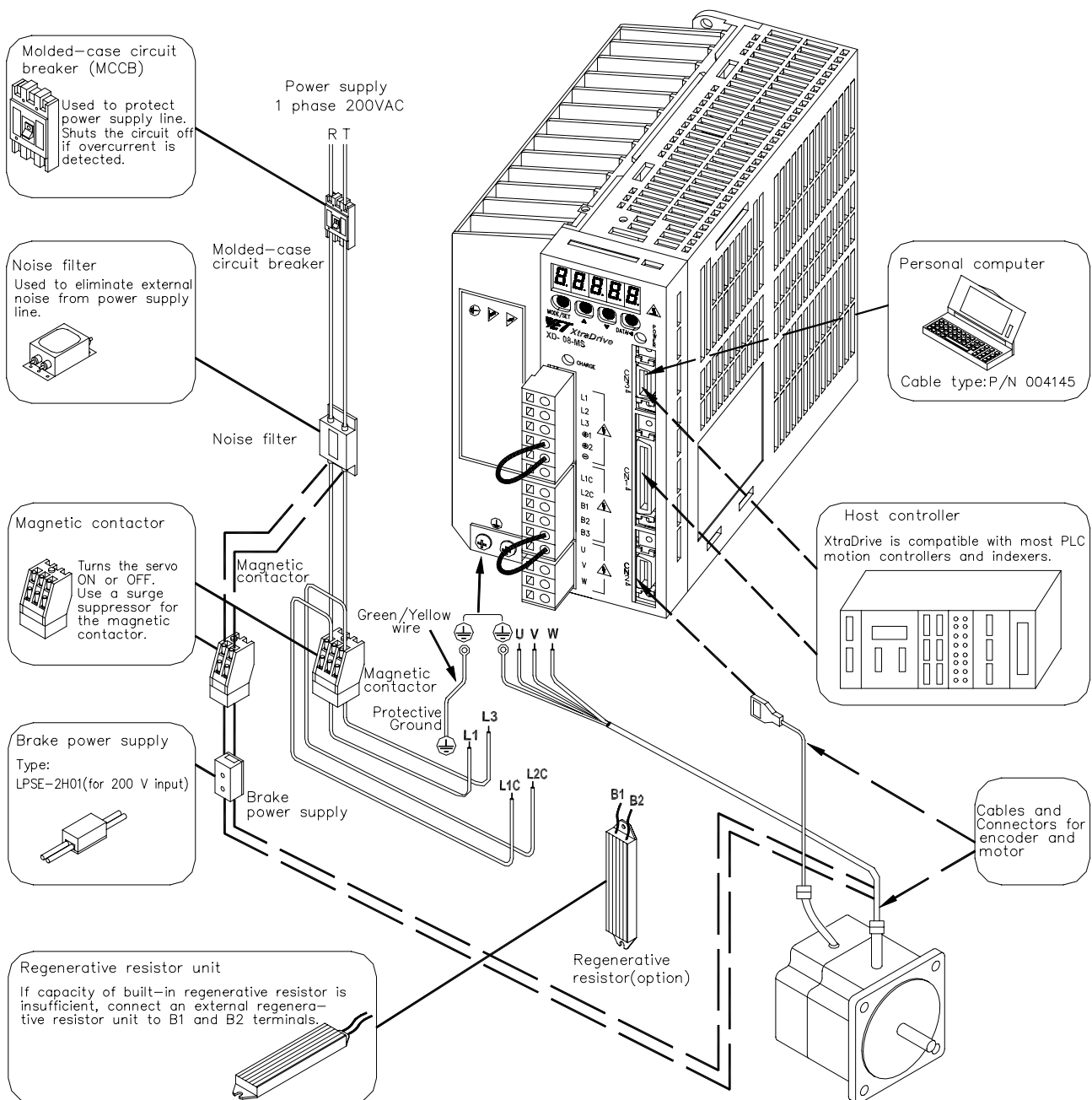

3.1.3. Three-phase 200V Main Circuit Specifications

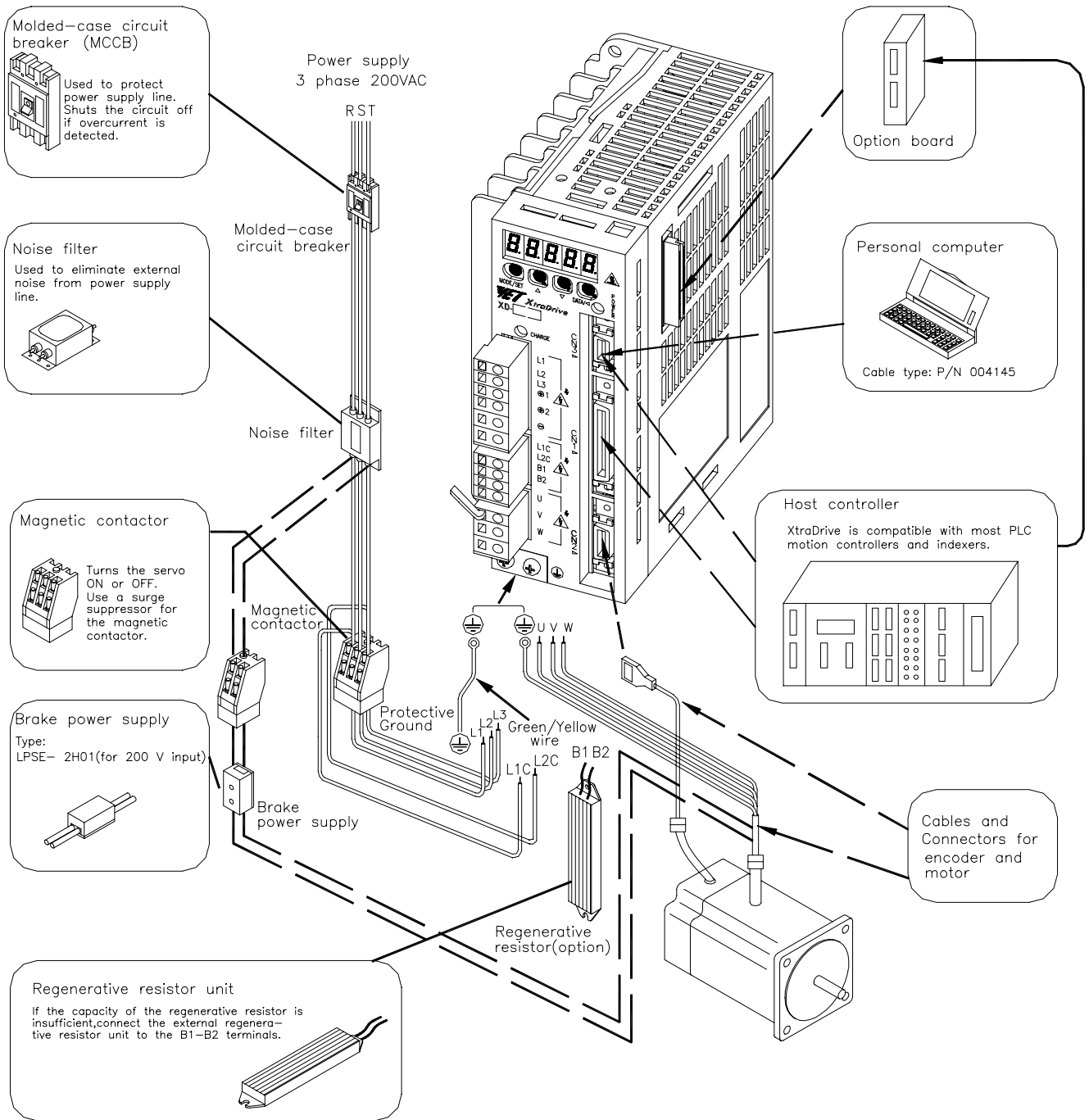

3.2.2. Three-phase 1kW to 3kW, 200V Models

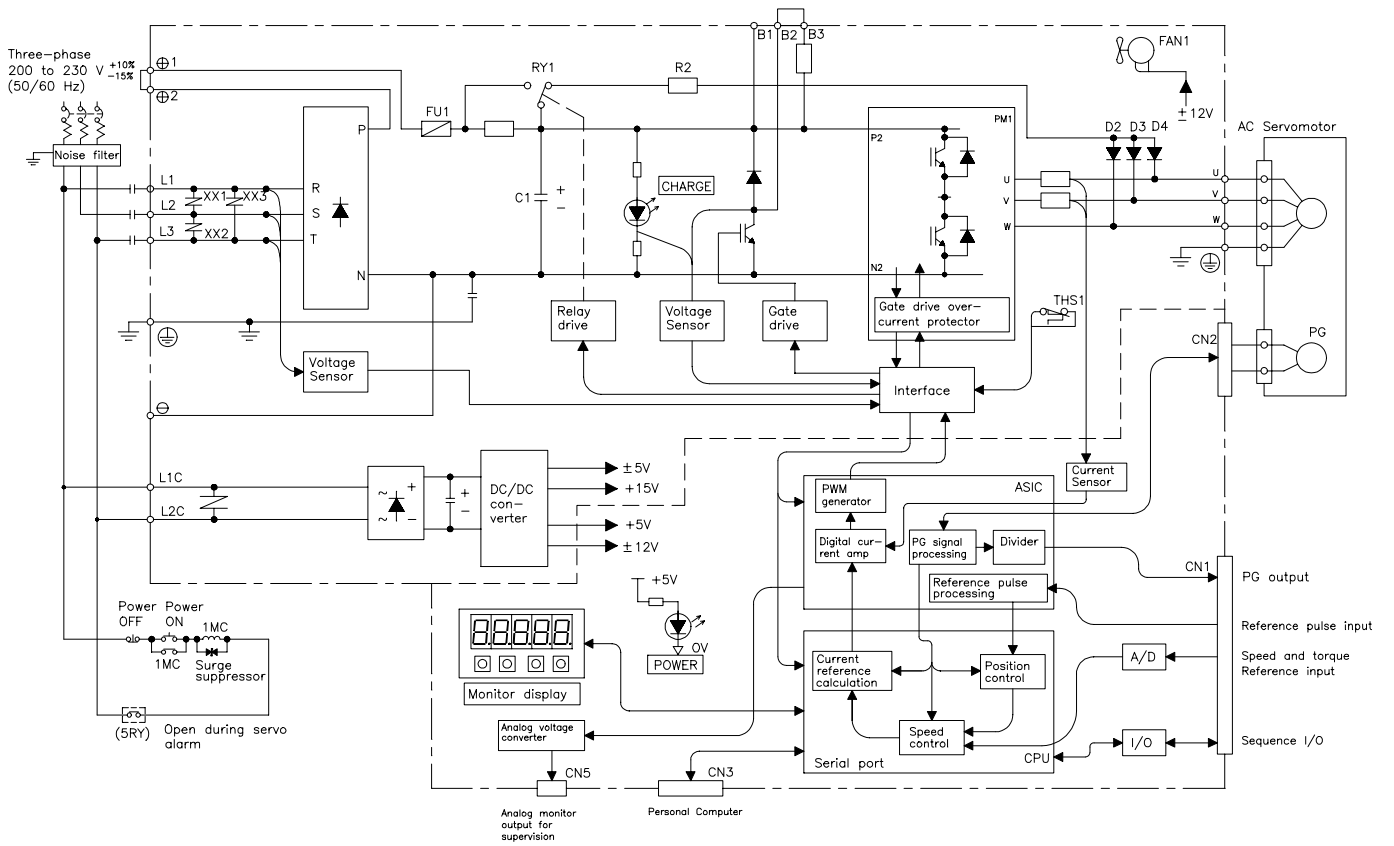

3.2.3. Three-phase 0.5kW to 3.0kW, 400V Models

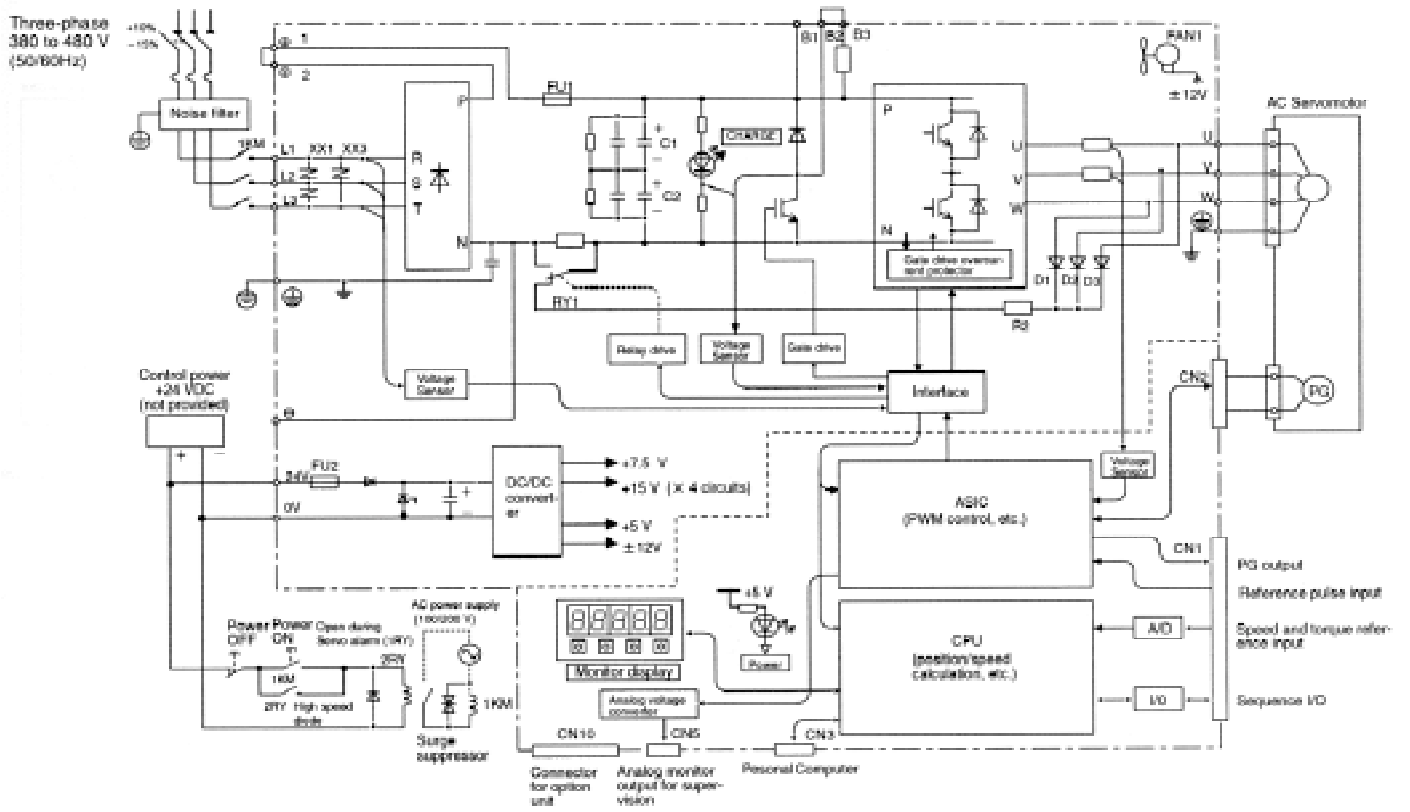

3.3. Main Circuit Wiring

This section shows typical examples of main circuit wiring for XtraDrive Series servo products, functions of main circuit terminals, and the power ON sequence.

Observe the following precautions when wiring.

CAUTION

- **Do not bundle or run power and signal lines together in the same duct. Keep power and signal lines separated by at least 30cm (11.81 in).**

Not doing so may cause a malfunction.

- **Use twisted pair wires or multi-core shielded-pair wires for signal and encoder (PG) feedback lines.**

The maximum length is 3m (118.11 in) for reference input lines and is 20m (787.40 in) for PG feedback lines.

- **Do not touch the power terminals for 5 minutes after turning power OFF because high voltage may still remain in the servo amplifier.**

Make sure the charge indicator is out first before starting an inspection.



- **Avoid frequently turning power ON and OFF. Do not turn power ON or OFF more than once per minute.**

Since the servo amplifier has a capacitor in the power supply, a high charging current flows for 0.2s when power is turned ON. Frequently turning power ON and OFF causes main power devices like capacitors and fuses to deteriorate, resulting in unexpected problems.

3.3.1. Names and Descriptions of Main Circuit Terminal

The following table gives the names and a description of main circuit terminals.

Table 3.1: Main Circuit Names and Description

Terminal Symbol	Name	Description	
L1, L2	Main circuit AC input terminal	30W to 1kW	Single-phase 200 to 230V (+10%, -15%), 50/60Hz
L1, L2, L3*		1kW to 3kW	Three-phase 200 to 230V (+10%, -15%), 50/60Hz
		2kW to 3.0kW 400V	Three-phase 380 to 480V (+10%, -15%), 50/60Hz
U, V, W	Servomotor connection terminal	Connects to the Servomotor.	
L1C, L2C	Control power input terminal	30W to 3.0kW	Single-phase 200 to 230V (+10%, -15%), 50/60Hz
24V, 0V			Three-phase 200 to 230V (+10%, -15%), 50/60Hz
			24VDC ($\pm 15\%$) 400V units only
 (2 places)	Ground terminal	Connects to the power supply ground terminals and motor ground terminal.	
B1, B2 or B1, B2, B3	External regenerative resistor terminal	30W to 400W	Normally not connected. Connect an external regenerative resistor (provided by customer) between B1 and B2 if the regenerative capacity is insufficient. Note: No B3 terminal.
		800W to 3.0kW	Normally short B2 and B3 (for an internal regenerative resistor). Remove the wire between B2 and B3 and connect an external regenerative resistor (provided by customer) between B1 and B2 if the capacity of the internal regenerative resistor is insufficient.
$\oplus 1, \oplus 2$	DC reactor terminal connection for power supply harmonic wave countermeasure	Normally short $\oplus 1$ and $\oplus 2$. If a countermeasure against power supply harmonic waves is needed, connect a DC reactor between $\oplus 1$ and $\oplus 2$. The amplifier is delivered from the factory with these terminals shorted. See 5.8.6 <i>Reactor for Harmonic Suppression</i> for details.	
	Main circuit Positive terminal	Normally not connected.	
	Main circuit Negative terminal	Normally not connected.	

*XtraDrive XD-08 has single-phase, 200V power supply specifications. Connect the following power supply between L1 and L3.

Single-phase 220 to 230 VAC ^{+10%, -15%} (50/60Hz)

When a power supply of 187V(-15% of 220V) or less is used, an alarm 41, indicating voltage shortage, may occur when accelerating to max speed with max torque of motor.

3.3.2. Typical Main Circuit Wiring Example

The following figure shows a typical example of main circuit wiring.

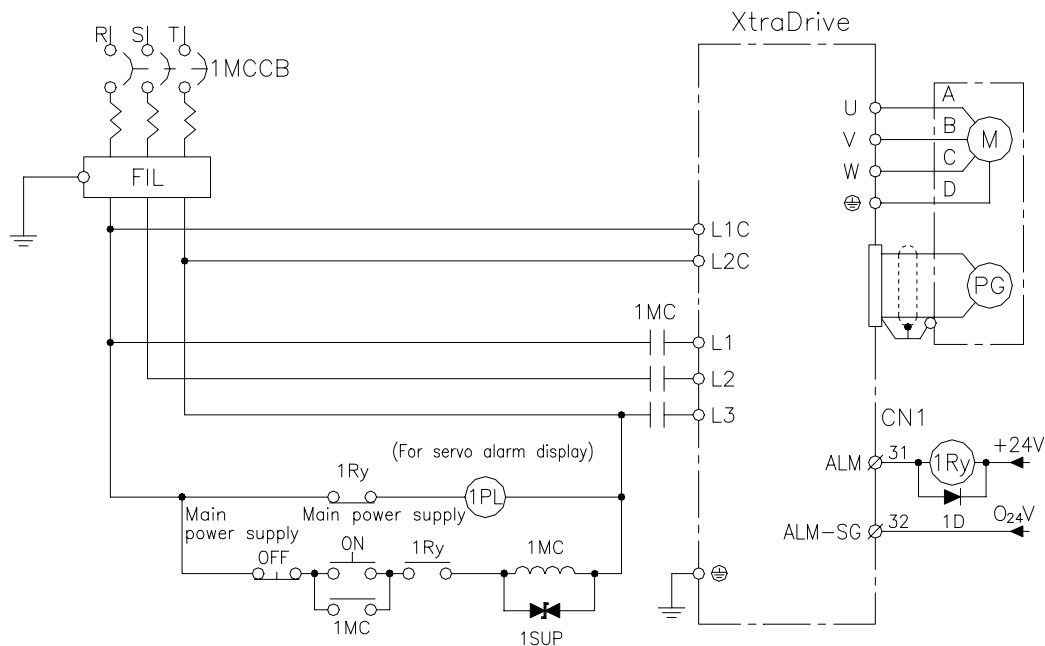

■ Designing a Power ON Sequence

Note the following when designing the power ON sequence.

- Design the power ON sequence so that power is turned OFF when a servo alarm signal is output. (See the circuit figure above.)
- Hold the power ON button for at least two seconds. The servo amplifier will output a servo alarm signal for two seconds or less when power is turned ON. This is required in order to initialize the servo amplifier.

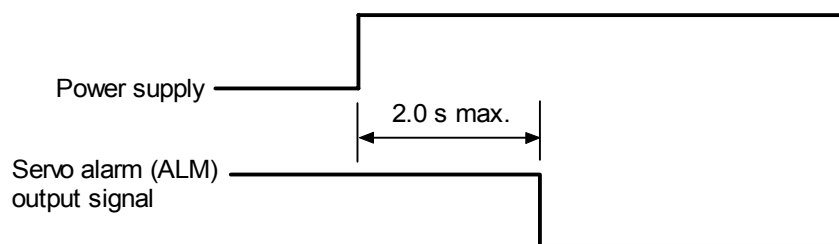

3.3.3. Servo Amplifier Power Losses

The following table shows servo amplifier power losses at the rated output.

Table 3.2: Servo Amplifier Power Losses at Rated Output

Main Circuit Power Supply	Maximum Applicable Servomotor Capacity [kW]	Servo Amplifier Model	Output Current (Effective Value) [A]	Main Circuit Power Loss [W]	Regenerative Resistor Power Loss [W]	Control Circuit Power Loss [W]	Total Power Loss [W]
Single-phase 200V	0.10	XD-01-**	0.91	6.7	—	13	19.7
	0.20	XD-02-**	2.1	13.3			26.3
	0.40	XD-04-**	2.8	20			33
	0.75	XD-08-**	4.4	47	12	15	74
Three-phase 200V	1.0	XD-10-**	7.6	55	12	15	82
	2.0	XD-20-**	18.5	120	28		163
	3.0	XD-30-**	7.5	60			198
Three-phase 400V	0.45	XD-05-**	1.9	19	14	15	48
	1.0	XD-10-**	3.5	35			64
	1.5	XD-15-**	5.4	53			82
	2.0	XD-20-**	8.4	83	28		161
	3.0	XD-30-**	11.9	118			243

Note: Regenerative resistor power losses are allowable losses. Take the following action if this value is exceeded:

- Disconnect the internal regenerative resistor in the servo amplifier by removing the wire between terminals B2 and B3.
- Install an external regenerative resistor between terminals B1 and B2.

See 5.6 *Selecting a Regenerative Resistor* for more details on the resistors.

3.3.4. Wiring Main Circuit Terminal Blocks

Observe the following precautions when wiring main circuit terminal blocks.

⚠ CAUTION

- Remove the terminal block from the servo amplifier prior to wiring.
- Insert only one wire per terminal on the terminal block.
- Make sure that the core wire is not electrically shorted to adjacent core wires.
- Reconnect any wires that were accidentally pulled out.

Servo amplifiers with a capacity below 1.5kW will have connector-type terminal blocks for main circuit terminals. Follow the procedure below when connecting to the terminal block.

■ Connection Procedure

- Strip the end of the wire, leaving the ends twisted together.

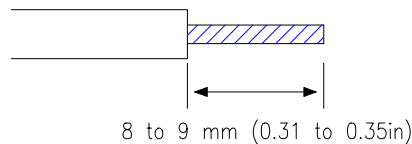

- Open the wire insert opening of the terminal block (plug) with a tool using either of the two procedures shown in Fig. A and Fig. B on the following page.

1. **Fig. A:** Use the provided lever to open the wire insert opening .

Fig. B: Using a commercially available 1/8in (3.0 to 3.5mm) slotted screwdriver, press down firmly on the screwdriver insert opening to release the wire insert slot.

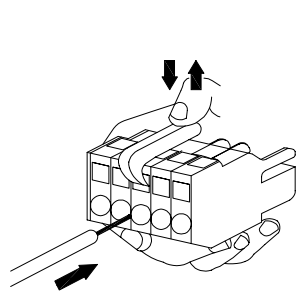

Fig. A

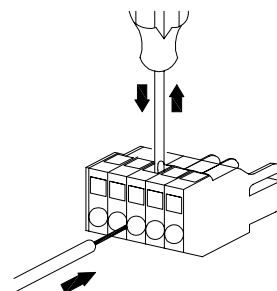

Fig. B

2. **Figs A and B:** Insert the wire end into the opening and then clamp it tightly by releasing either the lever or the screwdriver.

3.4. I/O Signals

This section describes I/O signals for the XtraDrive servo amplifier.

3.4.1. Example of Typical I/O Signal Connections

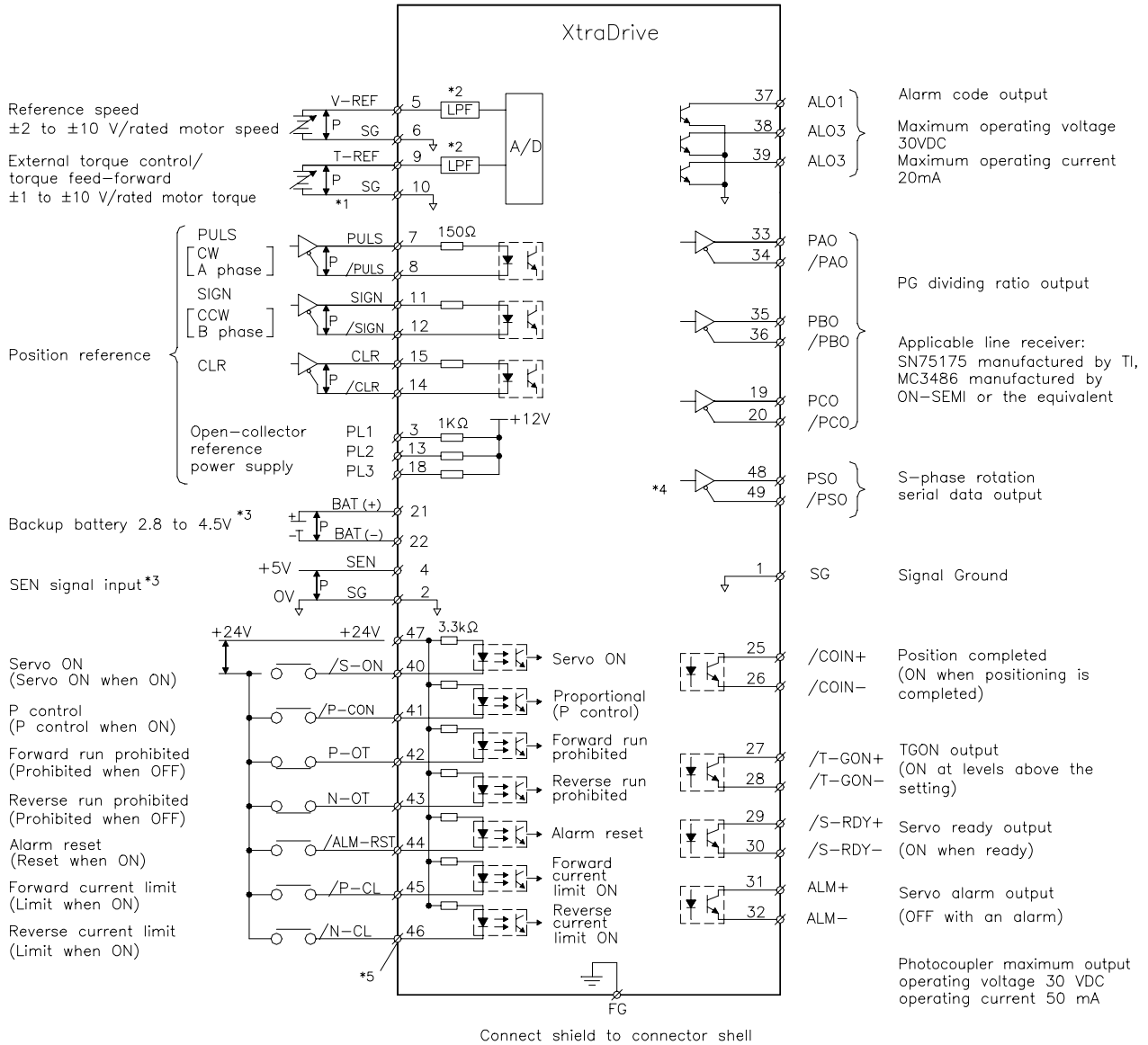

3.4.3. I/O Signal Names and Functions

The following section describes servo amplifier I/O signal names and functions.

■ Input Signals

Signal Name		Pin No.	Function		Reference	
Common	/S-ON	40	Servo ON: Turns ON the servomotor when the gate block in the inverter is released.		5.5.2	
	/P-CON	41	* Function selected via parameter.		5.2.1 5.2.7	
			Proportional operation reference	Switches the speed control loop from PI (proportional/integral) to P (proportional) control when ON.	5.2.1	
			Direction reference	With internal reference speed selected: Switches the direction of rotation.	5.2.6	
			Control mode switching	Position \leftrightarrow Speed Speed \leftrightarrow Torque Torque \leftrightarrow Speed	Enables control mode switching.	5.2.7
			Zero-clamp reference	Speed control with zero-clamp function: reference speed is zero when ON.		
			Reference pulse block	Position control with reference pulse stop: stops reference pulse input when ON.	5.2.10	
	P-OT	42	Forward Run prohibited Reverse Run prohibited	Overtravel prohibited: stops servomotor when movable part travels beyond the allowable range of motion.	5.1.2	
	N-OT	43				
	/P-CL /N-CL	45 46	* Function selected with a parameter.		—	
			Forward current limit ON Reverse current limit ON	Current limit function used when ON.	5.1.3	
			Internal speed switching	With internal reference speed selected: switches the internal speed settings.	5.2.6	
	/ALM-RST	44	Alarm reset: Releases the servo alarm state.		5.5.1	
	+24VIN	47	Control power supply input for sequence signals: users must provide the +24V power supply.		5.2.4	
SEN	4 (2)	Initial data request signal when using an absolute encoder.		5.2.3		
BAT+ BAT-	21 22	Connecting pins for the absolute encoder backup battery.		5.2.3		
Speed Reference	V-REF	5 (6)	Speed reference input: ± 2 to $\pm 10V$ /rated motor speed (Input gain can be modified with a parameter.)		5.2.1	
Torque Reference	T-REF	9 (10)	Torque reference input: ± 1 to $\pm 10V$ /rated motor speed (Input gain can be modified with a parameter.)		5.2.1	
Position Reference	PULS	7	Corresponds to reference pulse input Line-driver Open-collector	Input mode • Code + pulse string • CCW/CW pulse • Two-phase pulse (90° phase differential)	5.2.1	
	/PULS	8				
	SIGN	11				
	/SIGN	12				
	CLR /CLR	15 14	Error counter clear: Clears the error counter during position control.		5.2.1	
	PL1 PL2 PL3	3 13 18	+12V pull-up power supply when PULS, SIGN and CLR reference signals is open-collector outputs (+12V power supply is built into the servo amplifier).		5.2.1	

- Note:**
1. The functions allocated to /S-ON, /P-CON, P-OT, N-OT, /ALM-RST, /P-CL, and /N-CL input signals can be changed with parameters. (See 5.3.3 Input Circuit Signal Allocation.)
 2. Pin numbers in parenthesis () indicate signal grounds.
 3. The voltage input range for speed and torque references is a maximum of $\pm 12V$.

■ Output Signals

Signal Name		Pin No.	Function		Reference
Common	ALM+	31	Servo alarm: Turns OFF when an error is detected.		5.5.1
	ALM-	32			
	/TGON+	27	Detection during servomotor rotation: detects whether the servomotor is rotating at a speed higher than the motor speed setting. Motor speed detection can be set via parameter.		5.5.5
	/TGON-	28			
	/S-RDY+	9	Servo ready: ON if there is no servo alarm when the control/main circuit power supply is turned ON.		5.5.6
	/S-RDY-	30			
	PAO	33(1)	A phase signal	Converted two-phase pulse (A and B phase) encoder output signal and origin pulse (C phase) signal: RS-422 or the equivalent.	5.2.3
	/PAO	34			
	PBO	35			
/PBO	36				
PCO	19	C phase signal			
/PCO	20				
PSO	48	S phase signal	With an absolute encoder: outputs serial data corresponding to the number of revolutions (RS-422 or equivalent).		
/PSO	49				
	ALO1	37	Alarm code output: Outputs 3-bit alarm codes. Open-collector: 30V and 20mA rating maximum.		5.5.1
	ALO2	38			
	ALO3	39(1)			
	TMON	16	Analog monitor signal		
	VTG	17	Analog monitor signal		
Speed	/V-CMP+	25	Speed coincidence (output in Speed Control Mode): detects whether the motor speed is within the setting range and if it matches the reference speed value.		5.5.4
	/V-CMP-	26			
Position	/COIN+	25	Positioning completed (output in Position Control Mode): turns ON when the number of error pulses reaches the value set. The setting is the number of error pulses set in reference units (input pulse units defined by the electronic gear).		5.5.3
	/COIN-	26			
Not used.		23	These terminals are not used. Do not connect relays to these terminals.		—
		24			
		50			

- Note:**
1. Pin numbers in parenthesis () indicate signal grounds.
 2. The functions allocated to /TGON, /S-RDY, and /V-CMP (/COIN) can be changed via parameters. Functions /CLT, /VCT, /BK, /WARN, and /NEAR signals can also be changed. (See 5.3.4 Output Circuit Signal Allocation).

3.4.4. Interface Circuits

This section shows examples of servo amplifier I/O signal connection to the host controller.

■ Interface for Reference Input Circuits

Analog Input Circuit

Analog signals are either speed or torque reference signals at the impedance below.

- Speed reference input: About 14kΩ
- Torque reference input: About 14kΩ

The maximum allowable voltage for input signals is ±12V.

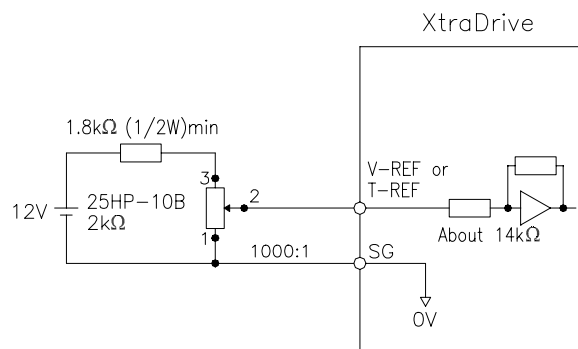

Reference Position Input Circuit

An output circuit for the reference pulse and error counter clear signal at the host controller can be either line-driver or open-collector outputs. These are shown below by type.

- Line-driver Output Example:

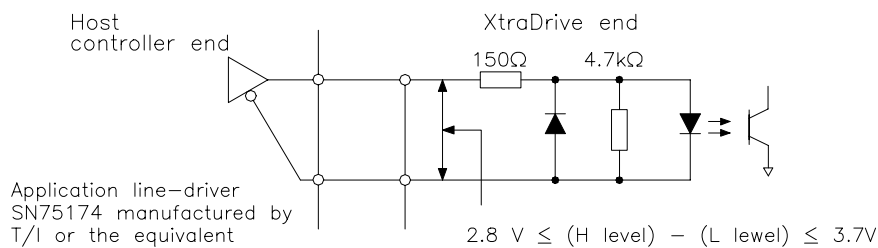

- Open-collector Output, Example 1: External power supply

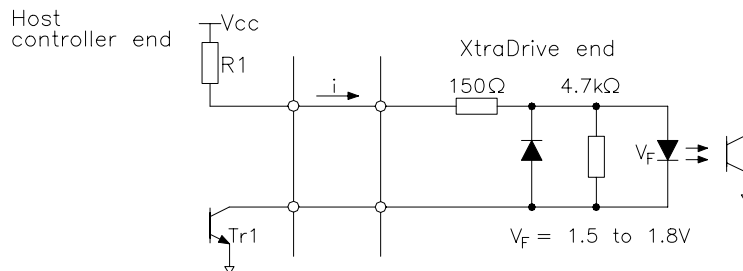

The following examples show how to select the pull-up resistor R1 so the input current (I) falls between 7 and 15mA.

Application Examples		
R1 = 2.2kΩ with V _{CC} = 24V ±5%	R1 = 1kΩ with V _{CC} = 12V ±5%	R1 = 180Ω with V _{CC} = 5V ±5%

- Open-collector Output, Example 2: Using a servo amplifier with an internal 12V power supply
This circuit uses the 12V power supply built into the servo amplifier. The input is not isolated in this case.

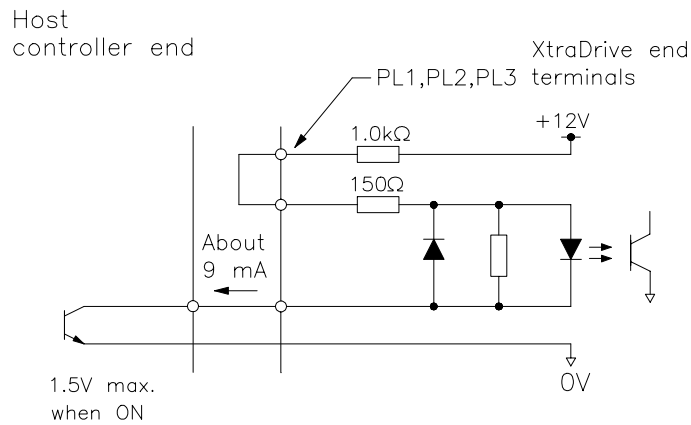

■ Sequence Input Circuit Interface

The sequence input circuit interface connects through a relay or open-collector transistor circuit. Select a low-current relay; otherwise a faulty contact will result.

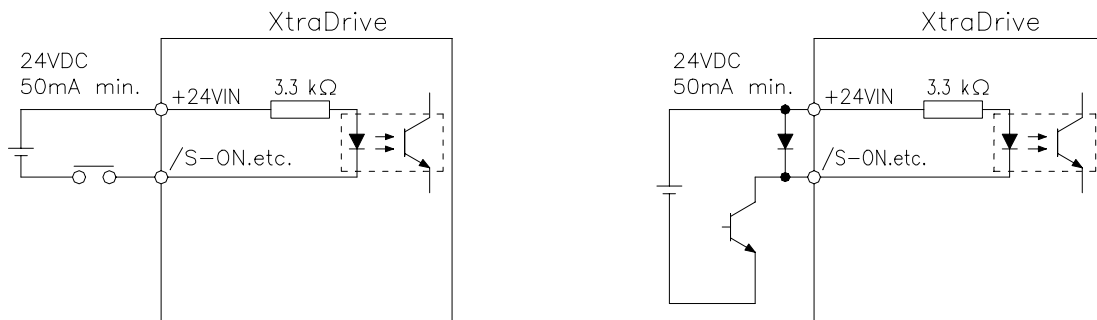

■ Output Circuit Interfaces

Any of the following three types of servo amplifier output circuits can be used. Connect an input circuit at the host controller following one of these types.

- Connecting to a Line-driver Output Circuit

Encoder serial data converted to two-phase (A and B phase) pulse output signals (PAO, /PAO, PBO, /PBO), origin pulse signals (PCO, /PCO) and S phase rotation signals (PCO, /PCO) are output via line-driver output circuits that normally comprise the position control system at the host controller. Connect the line-driver output circuit through a line receiver circuit at the host controller.

See 3.5 *Wiring Encoders* for connection circuit examples.

- Connecting to an Open-collector Output Circuit

Alarm code signals are output from open-collector transistor output circuits.

Connect an open-collector output circuit through an optocoupler, relay, or line receiver circuit.

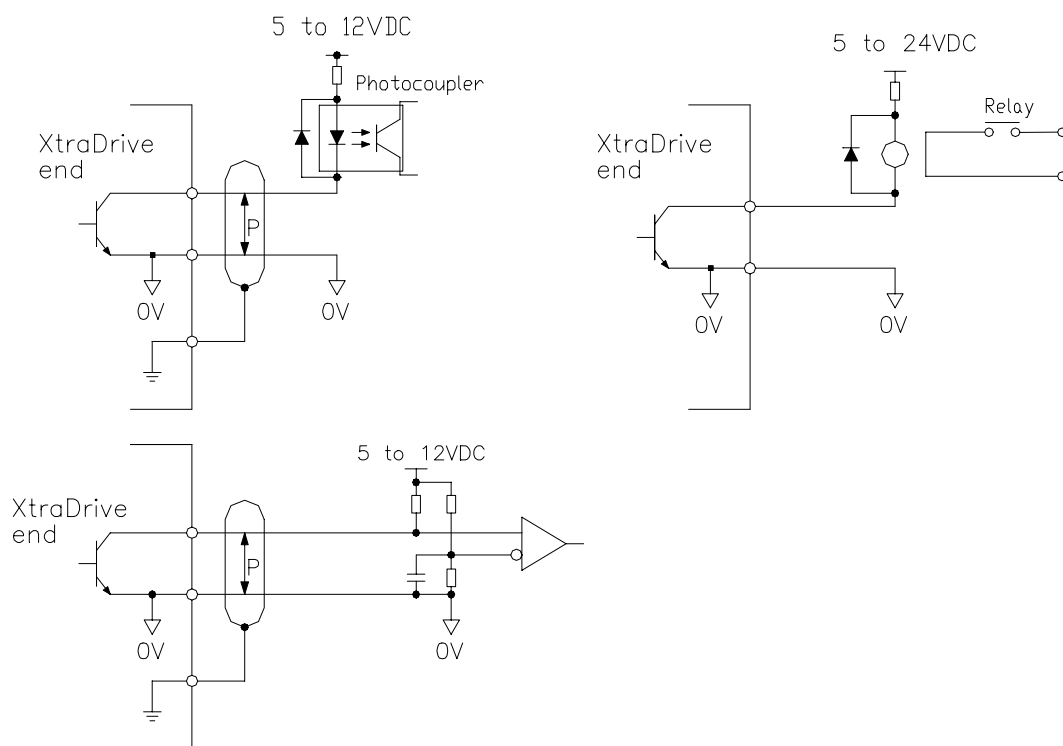

Note: The maximum allowable voltage and current capacities for open-collector circuits are:

- Voltage: $30V_{DC}$
- Current: $20mA_{DC}$

- Connecting an optocoupler output circuit

An optocoupler output circuits are used for servo alarm, servo ready, and other sequence output signal circuits.

Connect an optocoupler output circuit through a relay or line receiver circuit.

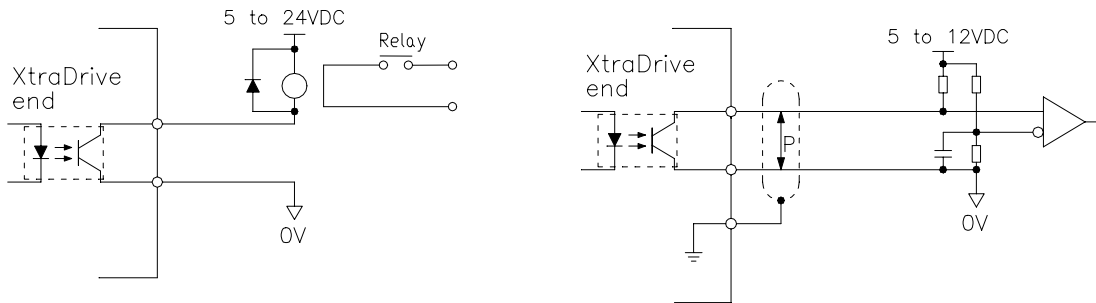

Note: The maximum allowable capacities for optocoupler output circuits are:

- Voltage: 30V_{DC}
- Current: 50mA_{DC}

- Connecting two XtraDrives (master-slave mode)

Connect output of “master” XtraDrive to “slave” XtraDrive’s input.

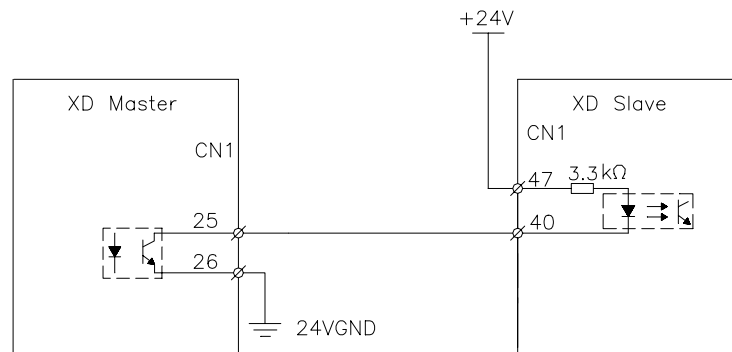

- Connecting an external load to XtraDrive’s output.

Maximum current: 50mA.

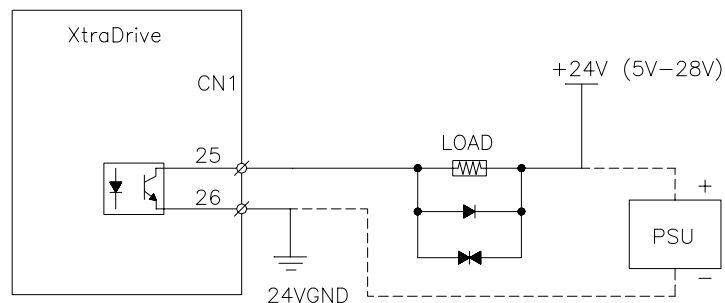

3.5. Wiring Encoders (for SGMGH and SGMSH Motors Only)

The following sections describe the procedure for wiring a servo amplifier to the encoder.

3.5.1. Encoder Connections

The following diagrams show the wiring of the encoder output from the motor to CN2 of the servo amplifier, and PG output signals from CN1 to the controller. This applies to both incremental and absolute encoders of SGMGH and SGMSH motors only.

■ Incremental Serial Encoders

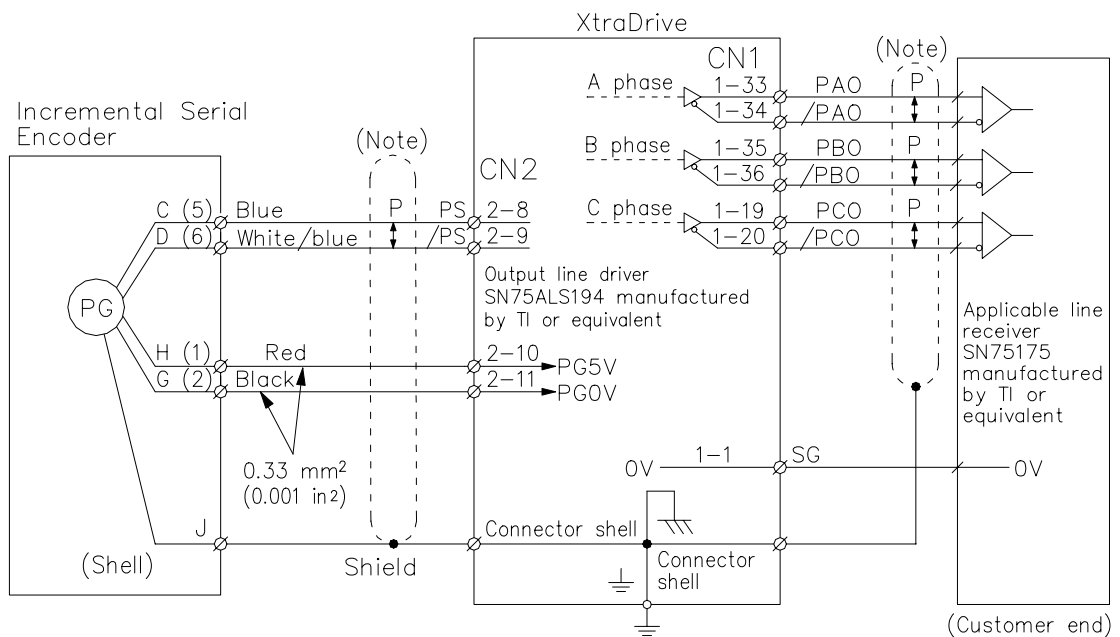

Absolute Serial Encoders

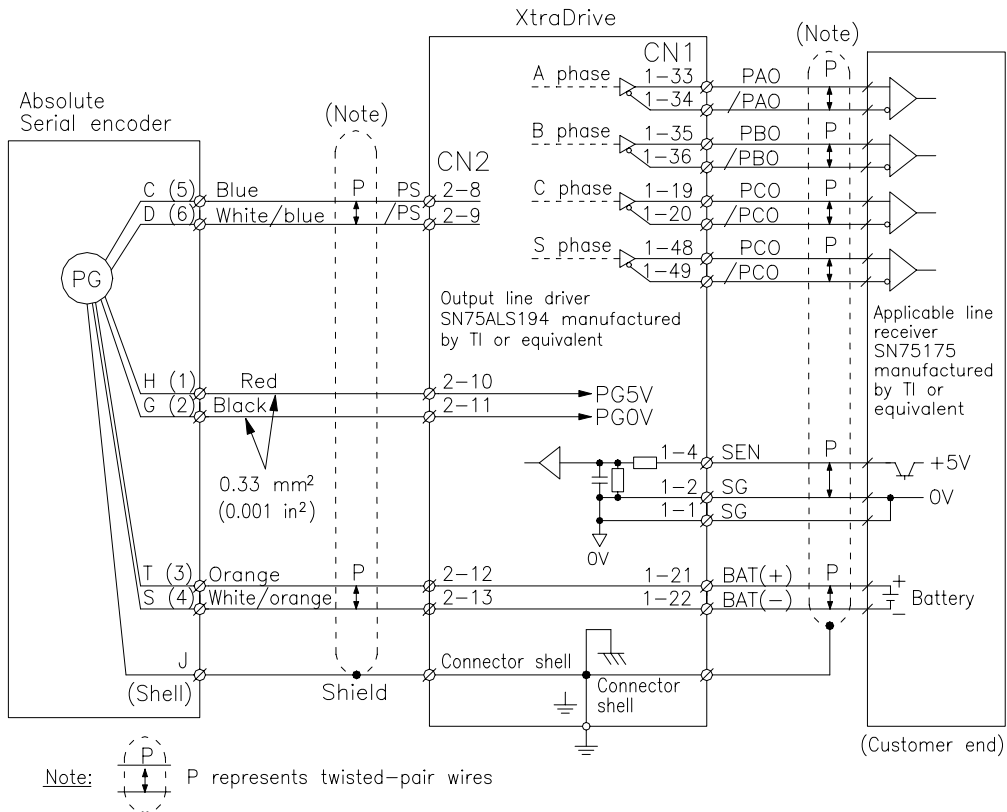

Incremental A/B+C Encoders

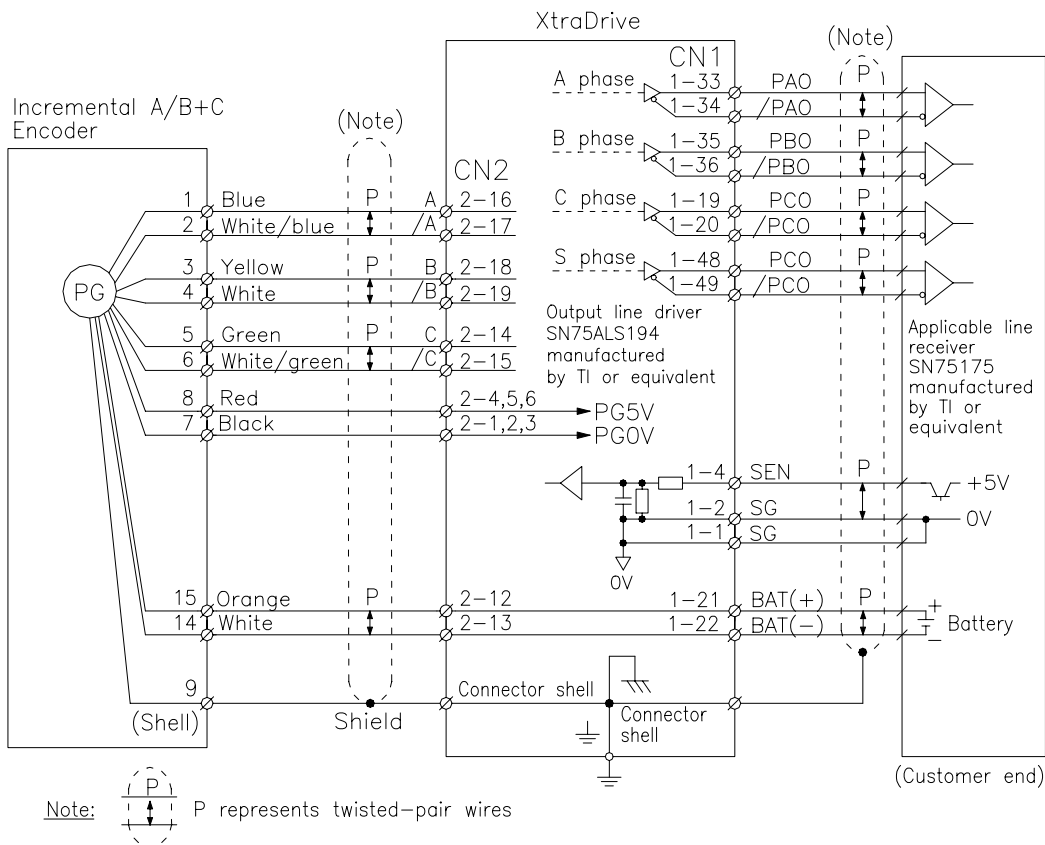

3.5.2. CN2 Encoder Connector Terminal Layout and Types

The following tables describe CN2 connector terminal layout and types.

■ CN2 Connector Terminal Layout

1	PPG0V	PG GND	2	PPG0V	PG GND	11	SPG0V	Serial PG GND	12	BAT+	Battery "+" input
3	PPG0V	PG GND	4	PPG5V	PG +5V	13	BAT-	Battery "-" input	14	PC	PG C-phase
5	PPG5V	PG +5V	6	PPG5V	PG +5V	15	/PC	PG /C-phase	16	PA	PG A-phase
7	NC*	-	8	PS	Serial PG S-phase	17	/PA	PG /A-phase	18	PB	PG B-phase
9	/PS	Serial PG /S-phase	10	SPG5V	Serial PG +5V	19	/PB	PG /B-phase	20	NC*	-

Note: NC* – Leave contact open.

■ Optional: CN2 Connector with Commutation Sensors Terminal Layout

1	PPG0V	PG GND	2	PPG0V	PG GND	11	SPG0V	GND	12	BAT+	Battery "+" input
3	PPG0V	PG GND	4	PPG5V	PG +5V	13	BAT-	Battery "-" input	14	PC	PG C-phase
5	PPG5V	PG +5V	6	PPG5V	PG +5V	15	/PC	PG /C-phase	16	PA	PG A-phase
7	/UIN	U – Phase Hall Effect	8	NC*	-	17	/PA	PG /A-phase	18	PB	PG B-phase
9	/VIN	V – Phase Hall Effect	10	SPG5V	+5V	19	/PB	PG /B-phase	20	/WIN	W – Phase Hall Effect

Note: NC* – Leave contact open.

■ CN2 Connector Models

XtraDrive Internal Connector	Applicable Plug (or Socket)		
	Soldered Plug	Case	Soldered Plug (Servomotor Side)
10220-52A2JL 20 PIN	MDR 10120-3000VE 20PIN (YET P/N: 4J4001)	10320-52A0-008 (YET P/N: 4J0101)	54280-0600 6PIN (YET P/N: 4J1521)

Note: The motor-end relay socket connects to the encoder connector for the SGMAH and SGMPH servomotors.

3.5.3. Encoder Cables Interconnections

This chapter shows interconnections for all standard encoder cables available from YET (Refer to YET Part Number). For additional types of encoders (like with communication sensors etc.) contact your YET representative.

■ Absolute A/B Encoder Cable

For Yaskawa SGM motors. (P/N 004143)

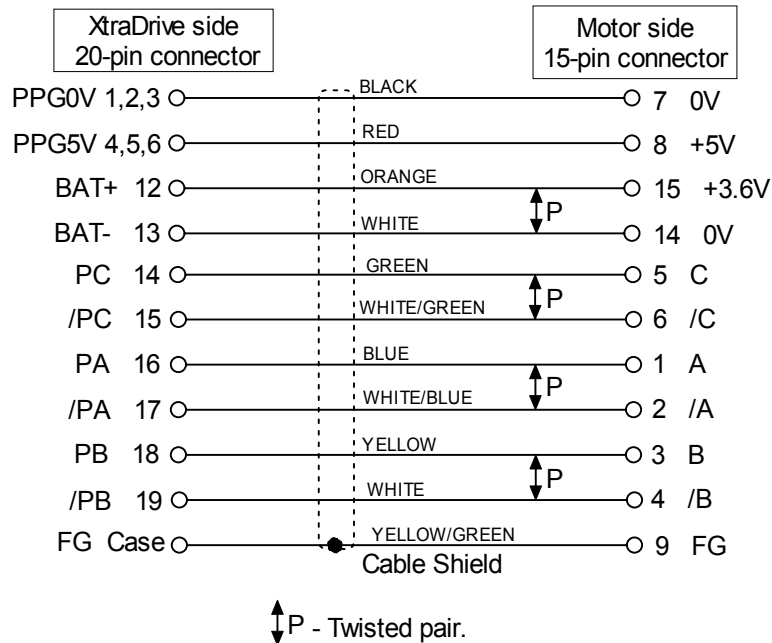

■ Incremental A/B Encoder Cable

For Yaskawa SGM motors. (P/N 004144)

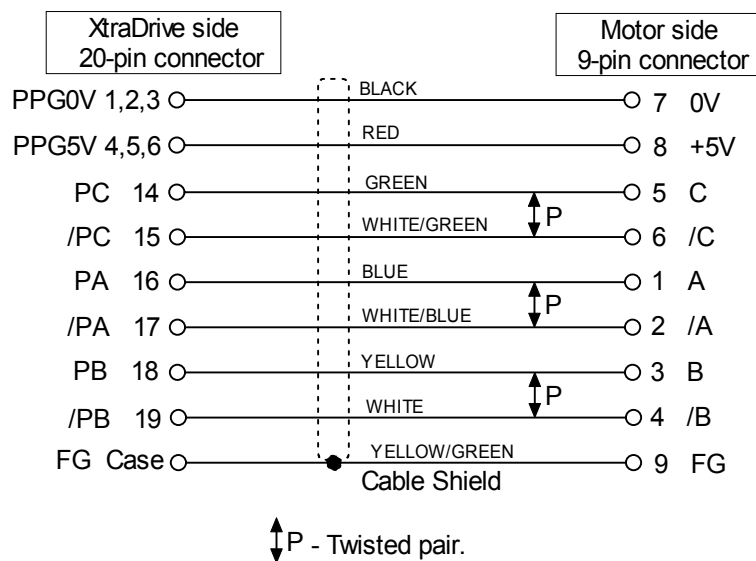

■ **Absolute Serial Encoder Cable**

For Yaskawa SGMAH motors. (P/N 004139)

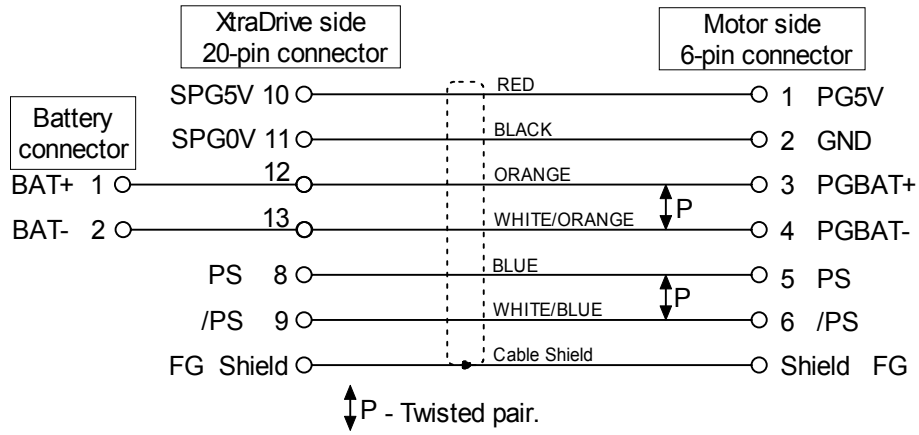

■ **Incremental Serial Encoder Cable**

For Yaskawa SGMAH motors. (P/N 004140)

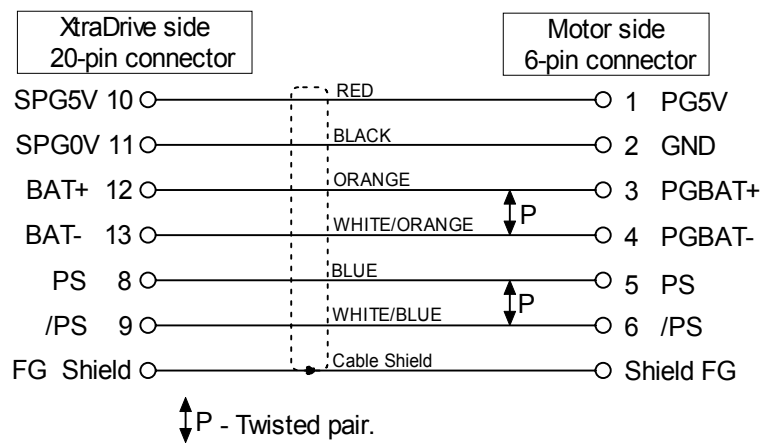

3.6. Examples of Standard Connections

The following diagrams show examples of standard servo amplifier connections by specifications and type of control.

Note for single-phase power supply specifications:

XtraDrive XD-08** have changed from three-phase specifications to single-phase. Main circuit connection terminals (L1, L2, L3) remained.

These devices have terminal B3 and internal regenerative resistor. Observe the following points.

1. Connect main power supply shown below to L1 and L3 terminals. Power supply is single-phase, 220 to 230 VAC +10% to -15%, 50/60Hz. If power supply of 187V (-15% of 220V) or less is used, alarm A41 indicating voltage shortage, may occur when accelerating to max speed with max torque of motor.
2. Short-circuit B2 and B3 terminals using the internal regenerative resistor. If capacity of the regenerative resistor is insufficient, remove the lead between B2 and B3 terminals and connect an external regenerative resistor unit to B1 and B2 terminals.

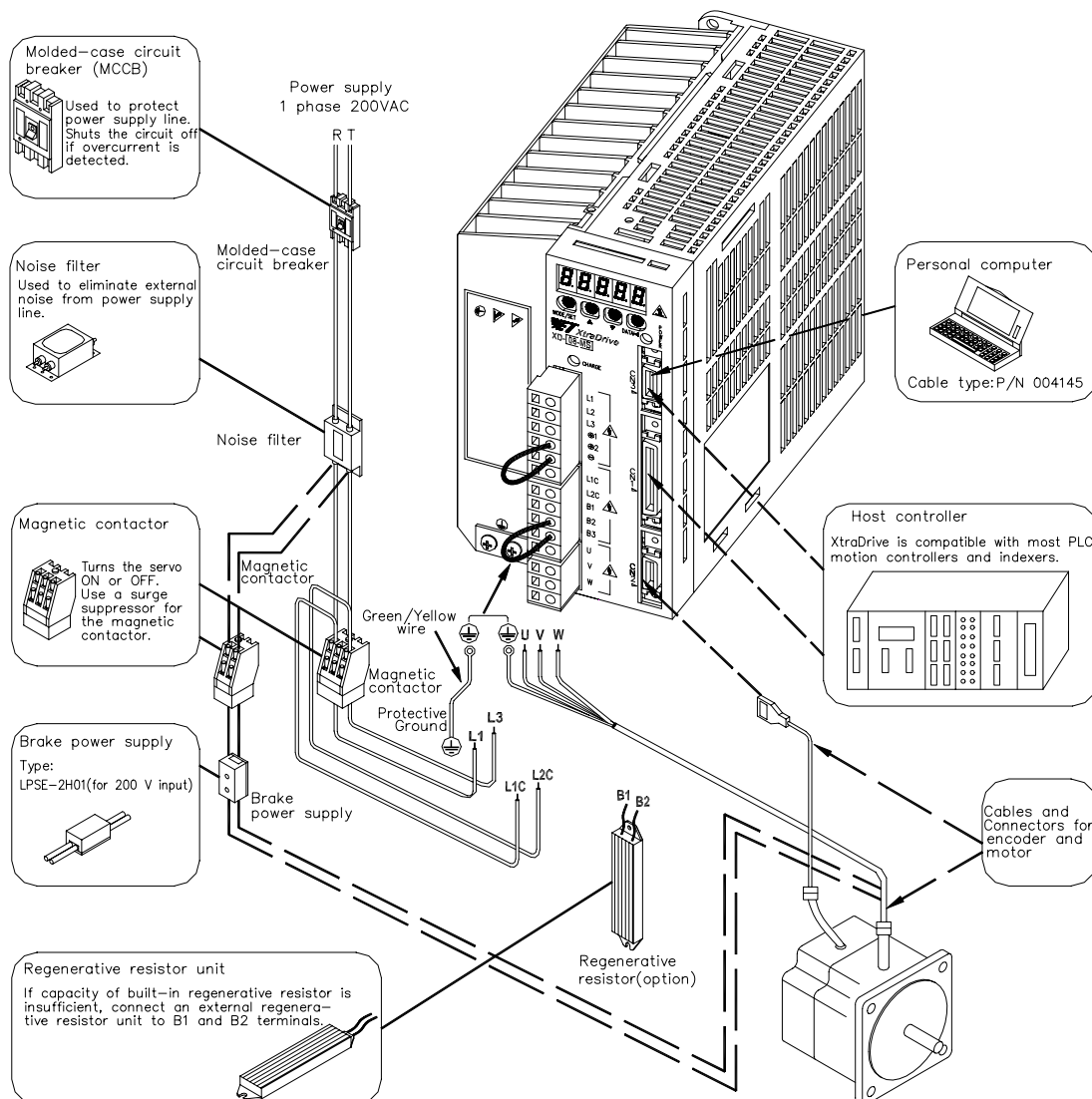

Position Control Mode

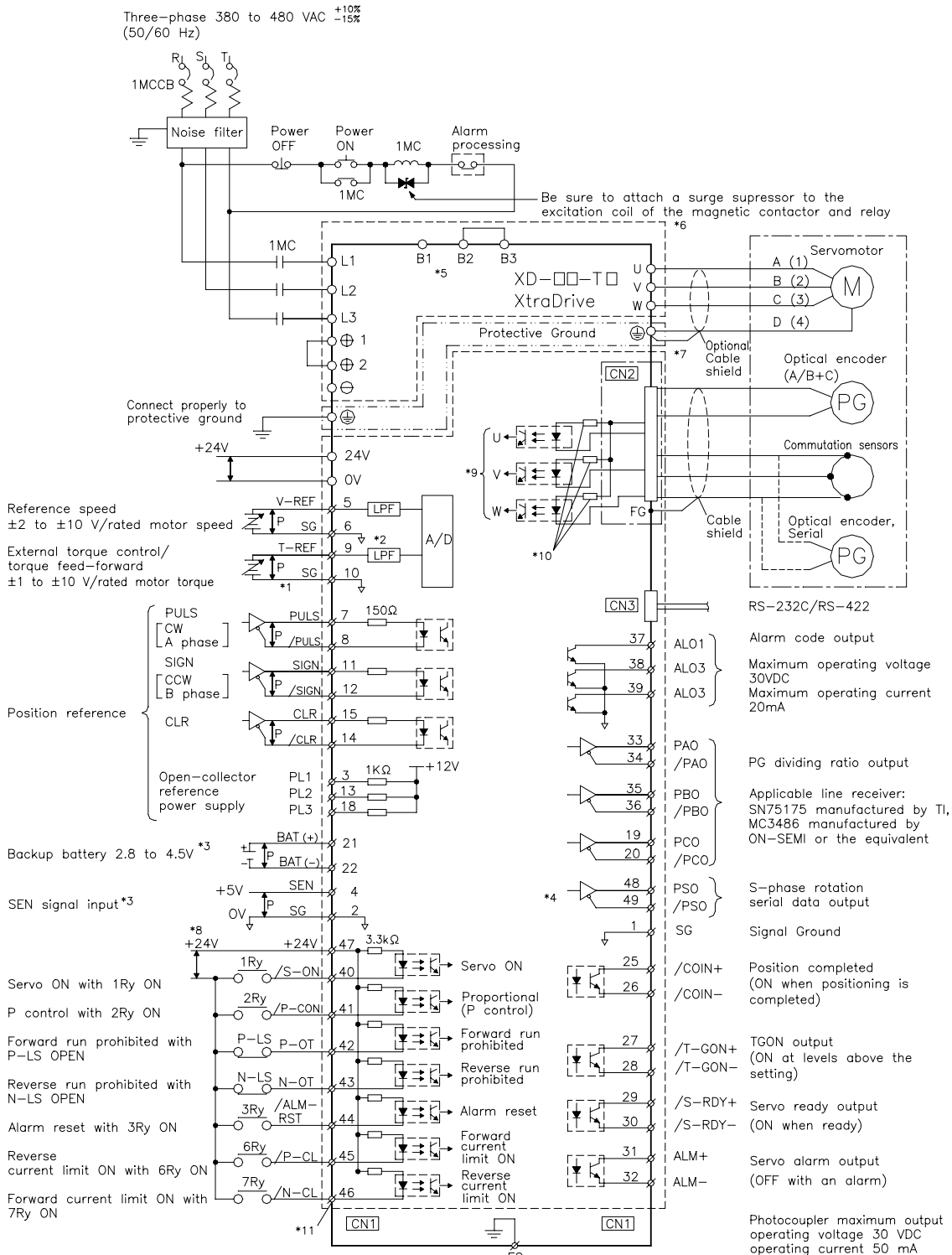

Connect shield to connector shell

- *1. P represents twisted-pair wires
- *2. The time constant for the primary filter is 47 μ s.
- *3. Connect only with an absolute encoder.
- *4. Used only with an absolute encoder.
- *5. Connect an external regenerative resistor between terminals B1 and B2.(for XtraDrives with big capacity)
- *6. These circuits are hazardous, therefore are separated by protecting separator.
- *7. These circuits are SELV circuits, therefore are separated from all other circuits by double and reinforced insulator.
- *8. Use a double-insulated 24-VDC power supply.
- *9. Optional – not available in all models.
- *10. Resistors are different for each model.
- *11. \emptyset Represents contacts of CN1 connector

Speed Control Mode

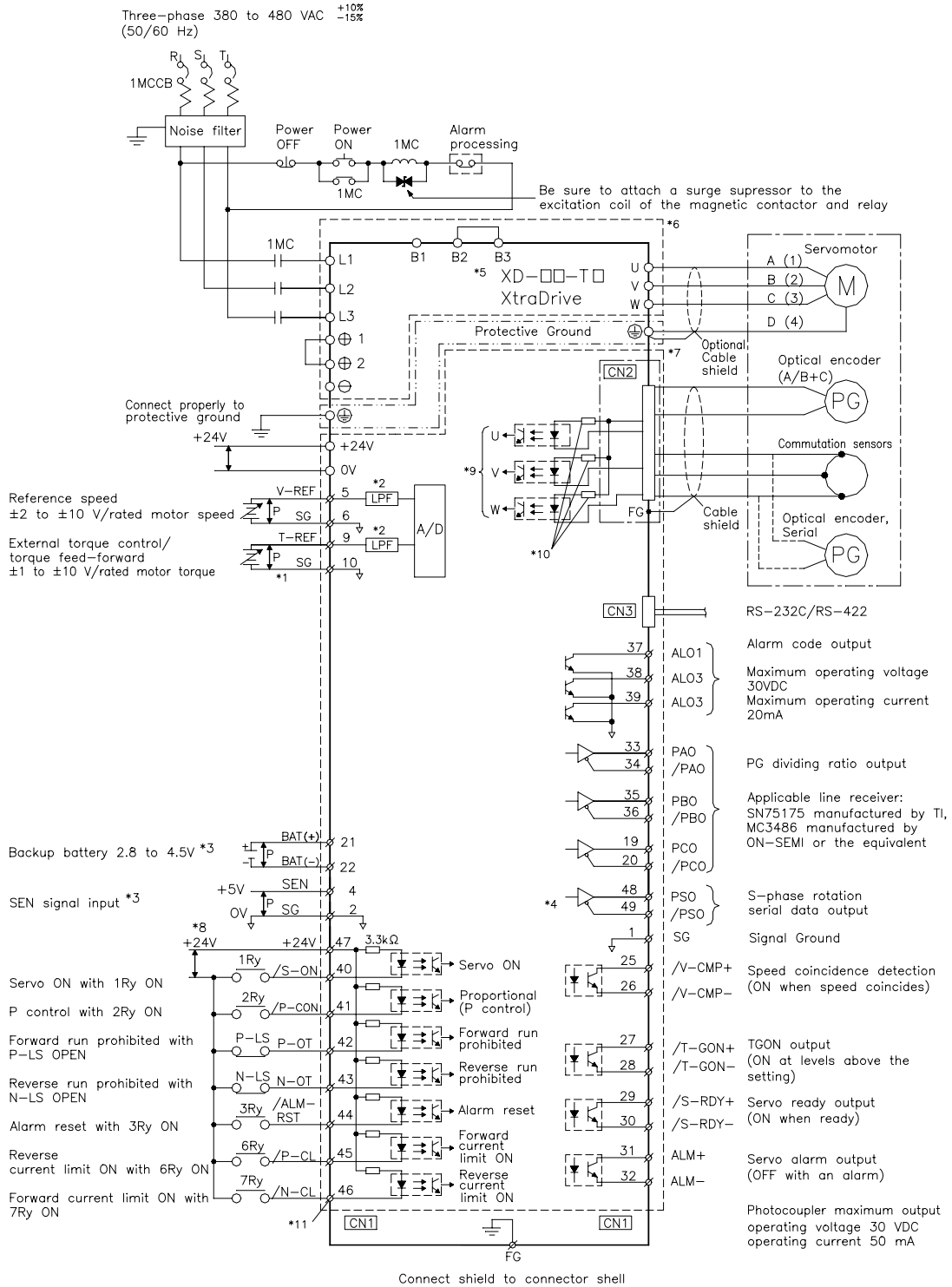

*1. P represents twisted-pair wires

*2. The time constant for the primary filter is 47us.

*3. Connect only with an absolute encoder.

*4. Used only with an absolute encoder.

*5. Connect an external regenerative resistor between terminals B1 and B2.(for XtraDrives with big capacity)

*6. These circuits are hazardous, therefore are separated by protecting separator.

*7. These circuits are SELV circuits, therefore are separated from all other circuits by double and reinforced insulator.

*8. Use a double-insulated 24-VDC power supply.

*9. Optional – not available in all models.

*10. Resistors are different for each model.

*11. ∅ Represents contacts of CN1 connector

Torque Control Mode

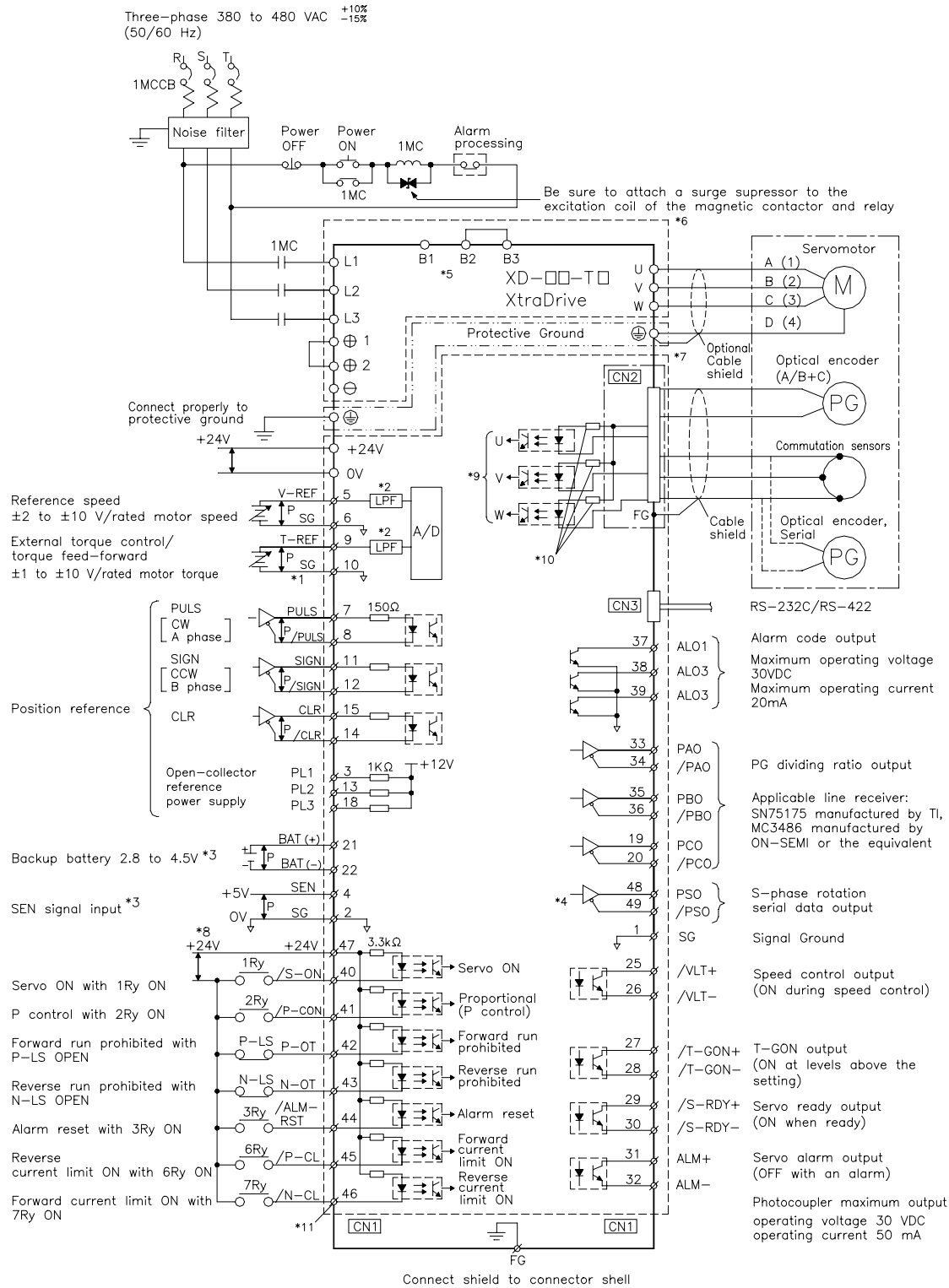

- *1. P represents twisted-pair wires
- *2. The time constant for the primary filter is 47us.
- *3. Connect only with an absolute encoder.
- *4. Used only with an absolute encoder.
- *5. Connect an external regenerative resistor between terminals B1 and B2.(for XtraDrives with big capacity)
- *6. These circuits are hazardous, therefore are separated by protecting separator.

- *7. These circuits are SELV circuits, therefore are separated from all other circuits by double and reinforced insulator.
- *8. Use a double-insulated 24-VDC power supply.
- *9. Optional – not available in all models.
- *10. Resistors are different for each model.
- *11. \emptyset Represents contacts of CN1 connector

This page intentionally left blank.

4. Trial Operation

This chapter describes a two-step trial operation. Be sure to complete step 1 before proceeding to step 2.

4.1.	Two-Step Trial Operation	4-2
4.1.1.	Step 1: Trial Operation for Servomotor without Load.....	4-3
4.1.2.	Step 2: Trial Operation with Servomotor Connected to Machine	4-9
4.2.	Additional Setup Procedures in Trial Operation.....	4-10
4.2.1.	Servomotors with Brakes	4-10
4.2.2.	Position Control by Host Controller	4-11
4.3.	Minimum Parameters and Input Signals.....	4-12
4.3.1.	Parameters	4-12
4.3.2.	Input Signals	4-12

4.1. Two-Step Trial Operation

Make sure that all wiring is completed prior to starting trial operation.

For your own safety, perform the trial operation in the order given below (step 1 and 2). See *4.1.1 Trial Operation for Servomotor without Load* and *4.1.2 Trial Operation for Servomotor Connected to Machine* for more details on the trial operation.

Step 1: Trial Operation for Servomotor without Load

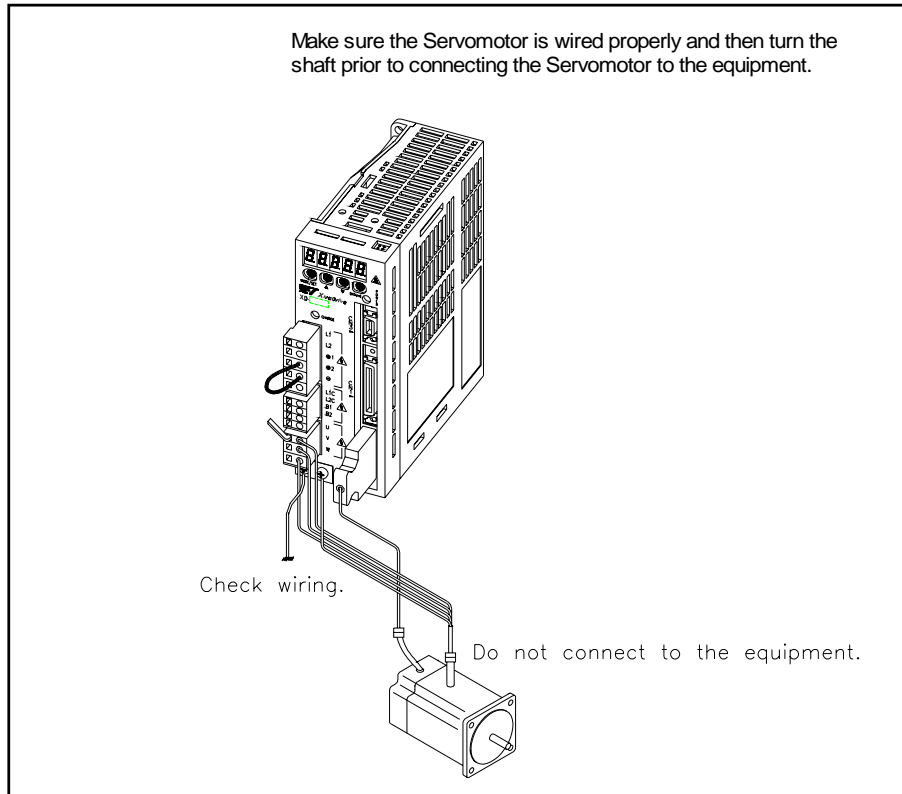

Step 2: Trial Operation with the Equipment and Servomotor Connected

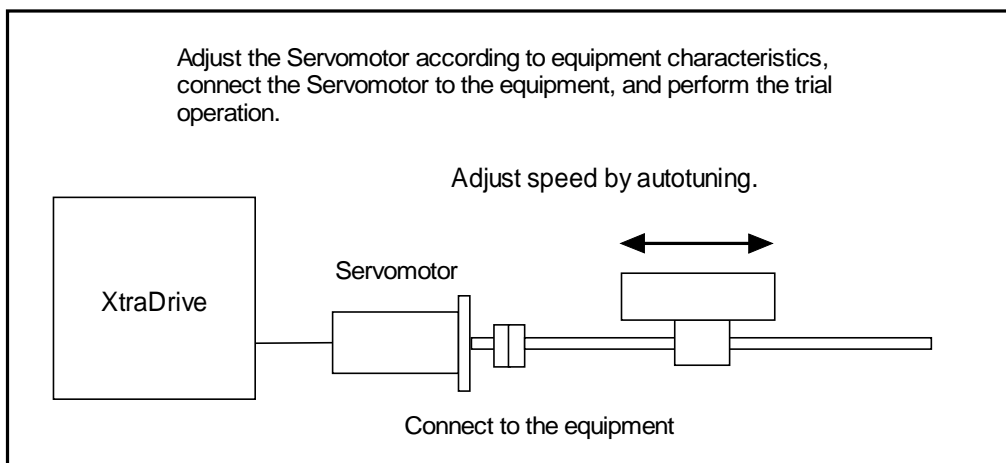

4.1.1. Step 1: Trial Operation for Servomotor without Load

! Caution

- **Do not operate the servomotor while it is connected to the equipment.**
To prevent accidents, initially perform step 1 where the trial operation is conducted under no-load conditions (with all couplings and belts disconnected).

In step 1, make sure that the servomotor is wired properly as shown below. Incorrect wiring is generally the reason why servomotors fail to operate properly during trial operation.

- Check main power supply circuit wiring.
- Check servomotor wiring.
- Check CN1 I/O signal wiring.

Make sure the host controller and other adjustments are completed as much as possible in step 1 (prior to connecting the servomotor to equipment).

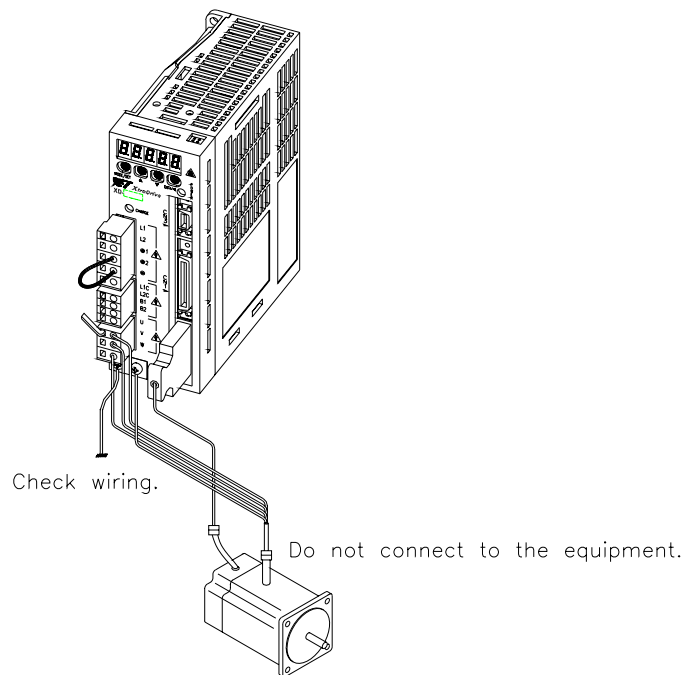

Note: Check the items on the following pages in the order given during the servomotor trial operation.
See 4.2.1 *Servomotors with Brakes*, if you are using a servomotor with brakes.

1. Secure the servomotor.

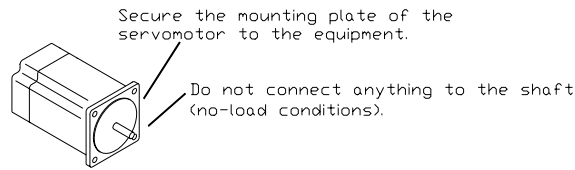

Secure the servomotor mounting plate to the equipment in order to prevent the servomotor from moving during operation.

2. Check the wiring.

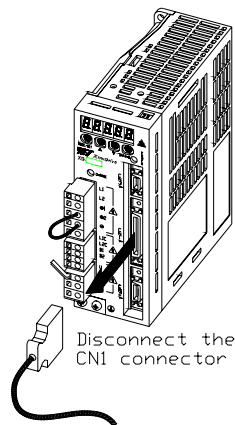

Disconnect the CN1 connector and check the servomotor wiring in the power supply circuit. CN1 I/O signals are not used, so leave the connector disconnected.

3. Turn ON power.

Normal display

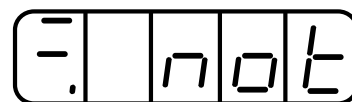
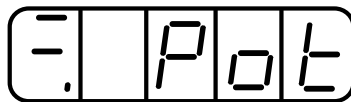

Alternative display

Example of alarm display



Turn ON the servo amplifier's power. If the servo amplifier has turned ON normally, the LED display on its front panel will appear as shown above. Power is not supplied to the servomotor because the servo is OFF.

If an alarm display appears on the LED indicator as shown above, the power supply circuit, servomotor wiring, or encoder wiring is incorrect. In this case, turn OFF power and take appropriate action. See *9.2 Troubleshooting*.

Note: If an absolute encoder is used, it must be set up. Refer to *5.7.4 Absolute Encoder Setup*.

4. Operate with the panel operator.

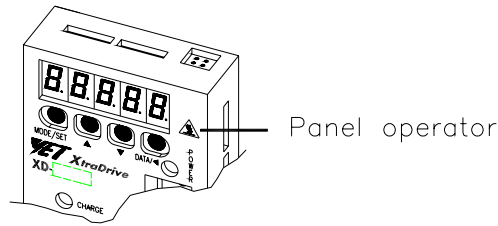

Operate the servomotor using the panel operator. Check to see if the servomotor runs normally.

See 7.2.2 *JOG Operation* for more details on the procedure.

5. Connect the signal lines.

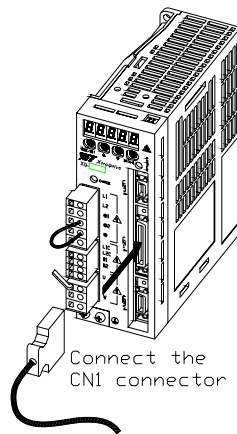

Use the following procedure to connect the CN1 connector.

- a) Turn OFF power.
- b) Connect the CN1 connector.
- c) Turn ON power again.

6. Check the input signals.

Check input signal wiring in Monitor Mode using the panel operator. See 7.1.6 *Operation in Monitor Mode* for more details on the procedure.

Turn ON and OFF each signal line to see if the LED monitor bit display on the panel changes as shown below.

Input signal LED display

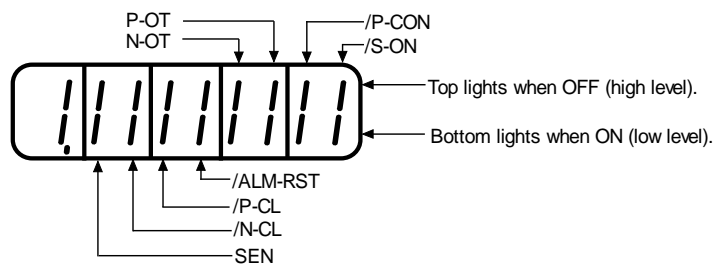

Input Signal Status	LED Display
OFF (high level)	Top LED indicators light.
ON (low level)	Bottom LED indicators light.

Note: The servomotor will not operate properly if the following signal lines are not wired correctly. Always wire them correctly. Short-circuit the signal lines if they will be unused. Input signal selections (parameters Pn50A to Pn50D) can be used to eliminate the need for external short-circuiting.

Signal Symbol	Connector Pin Number	Description
P-OT	CN1-42	The servomotor can rotate in forward direction when this signal line is low (0V).
N-OT	CN1-43	The servomotor can rotate in reverse direction when this signal line is low (0V).
/S-ON	CN1-40	The servomotor is turned ON when this signal line is low (0V). Leave the servomotor OFF.
+24VIN	CN1-47	Control power supply terminal for sequence signals.

Note: IF an absolute encoder is being used, the servo will not turn ON when the servo ON signal (/S-ON) is input unless the SEN signal is also ON. When the SEN signal is checked in Monitor mode, the top of the LED will light because the SEN signal is high when ON.

7. Turn ON the servo.

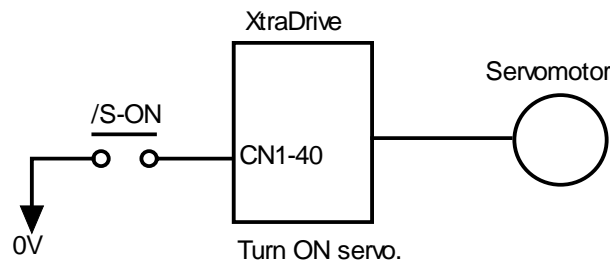

Turn ON the servo using the following procedure.

- a) Make sure there are no reference signal inputs.
 - Set V-REF (CN1-5) and T-REF (CN1-9) to 0V for speed and torque control.
 - Set PULS (CN1-7) and SIGN (CN1-11) to low for position control.
- b) Turn ON the servo ON signal.

Display with servo ON.

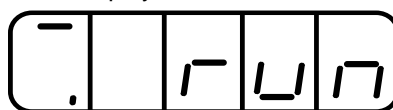

Set /S-ON (CN1-40) to 0V. If everything is normal, the servomotor will turn ON and the LED indicator on the front panel will display as shown above. If an alarm display appears, take appropriate action as described in 9.2 *Troubleshooting*.

Note: If there is noise in the reference voltage for speed control, the “-” on the left of the 7-segment LED may flash.

■ Operation Using Reference Input

The operating procedure here depends on the parameter settings (control mode selection at memory switch Pn000.1). Use the following procedure for operations with speed and position control.

Operating Procedure in Speed Control Mode: Set Pn000.1 to 0

This description applies to the standard speed control setting.

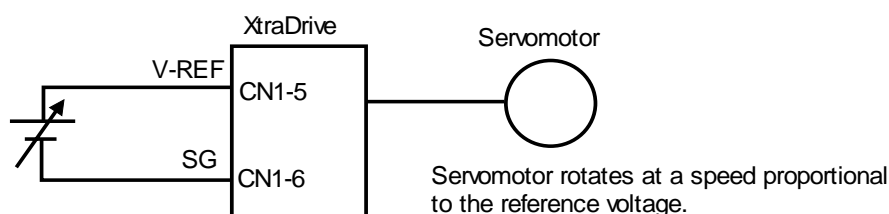

1. Gradually increase the reference speed input (V-REF, CN1-5) voltage. The servomotor will rotate.
2. Check the following items in Monitor mode. See 7.1.6 *Operation in Monitor Mode*.

Un000	Actual motor speed
Un001	Reference speed

- Has the reference speed been input?
 - Is the motor speed as defined?
 - Does the reference speed coincide with the actual motor speed?
 - Does the servomotor stop when the speed reference is 0?
3. If the servomotor rotates at extremely slow speed with 0V specified for the reference voltage, correct the reference offset value as described in 7.2.3 *Automatic Adjustment of the Speed and Torque Reference Offset* or 7.2.4 *Manual Adjustment of the Speed and Torque Reference Offset*.
 4. Reset the following parameters to change the motor speed or direction of rotation.

Pn300	Sets the reference speed input gain. See 5.2.1 <i>Speed Reference</i> .
Pn000.0	Selects the rotation direction. See 5.1.1 <i>Switching Servomotor Rotation Direction</i> .

Operating Procedure In Position Control Mode: Set Pn000.1 to 1

1. Set the parameter Pn200.0 so that the reference pulse form is the same as the host controller output form.

To select the reference pulse form: See 5.2.2 *Position Reference*.

2. Input a slow speed pulse from the host controller and execute low-speed operation.

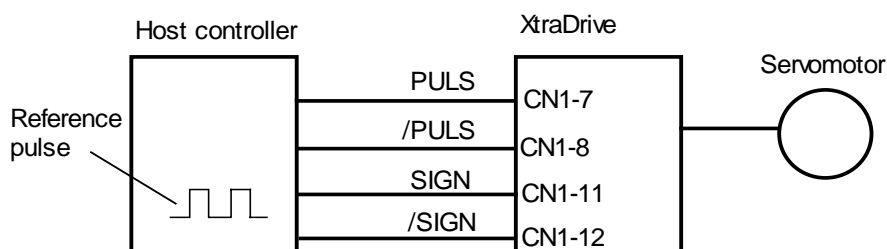

3. Check the following data in Monitor mode. See 7.1.6 *Operation in Monitor Mode*.

Un000	Actual motor speed
Un007	Reference pulse speed display
Un008	Position offset

- Has the reference pulse been input?
 - Is the motor speed as defined?
 - Does the reference speed coincide with the actual motor speed?
 - Does the servomotor stop when the speed reference is 0?
4. Reset the parameters shown below to change the motor speed or direction of rotation.

Pn202, Pn203	Electronic gear ratio See 5.2.5 <i>Using the Electronic Gear Function</i> .
Pn000.0	Selects the direction of rotation. See 5.1.1 <i>Switching Servomotor Rotation Direction</i> .

If an alarm occurs or the servomotor fails to operate during the above operation, the CN1 connector wiring is incorrect or the parameter settings do not match the host controller specifications. Check the wiring and review the parameter settings, then repeat step 1.

Note: References

- List of alarms: See 9.2.3 *Alarm Display Table*.
- List of parameters: See Appendix D *List of Parameters*.

4.1.2. Step 2: Trial Operation with Servomotor Connected to Machine

! Warning

Follow the procedure below for step 2 operation precisely as given.

Malfunctions that occur after the servomotor is connected to the equipment not only damage the equipment, but may also cause an accident resulting in death or injury.

Before proceeding to step 2, repeat step 1 (servomotor trial operation without a load) until all concerns including parameters and wiring have fully satisfied expectations.

After step 1 has been completed, proceed to step 2 for trial operation with the servomotor connected to the equipment. The servo amplifier is now adjusted in the following ways to meet the specific equipment's characteristics.

- Using autotuning to match the servo amplifier to the equipment's characteristics.
- Matching direction of rotation and speed to the equipment's specifications.
- Checking the final control form.

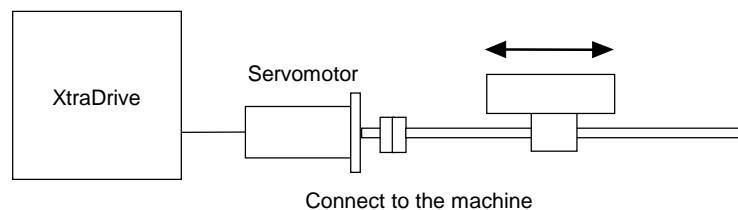

Follow the procedure below to perform the trial operation.

1. Make sure power is OFF.
2. Connect the servomotor to the equipment.
See *2.1 Servomotors* for more details on connecting the servomotor.
3. Use autotuning to match the servo amplifier to equipment characteristics.
See *6.3 Autotuning*.
4. Operate the servomotor by reference input.
As in step 1 (*Servomotor Trial Operation without Load*), operate the servomotor by reference input as described in *4.1.1 Step 1: Trial Operation for Servomotor without Load*. Tune to match the host controller at this time, as well.
5. Set and record user settings.
Set parameters as required and record all settings for later use during maintenance.

Note: The servomotor will not be broken in completely during the trial operation. Therefore, let the system run for a sufficient amount of time after trial operation has been completed to ensure that it is properly broken in.

4.2. Additional Setup Procedures in Trial Operation

For two equipment configurations, which are delineated in the subsequent sections, precautionary setup procedures must be followed before starting trial operation.

4.2.1. Servomotors with Brakes

Use a servomotor with a brake for vertical shaft applications or for the application of external force to the shaft to prevent rotation due to gravity or external force during a power loss.

The servo amplifier uses the brake interlock output (/BK) signal to control the holding brake operation when using servomotors with brakes.

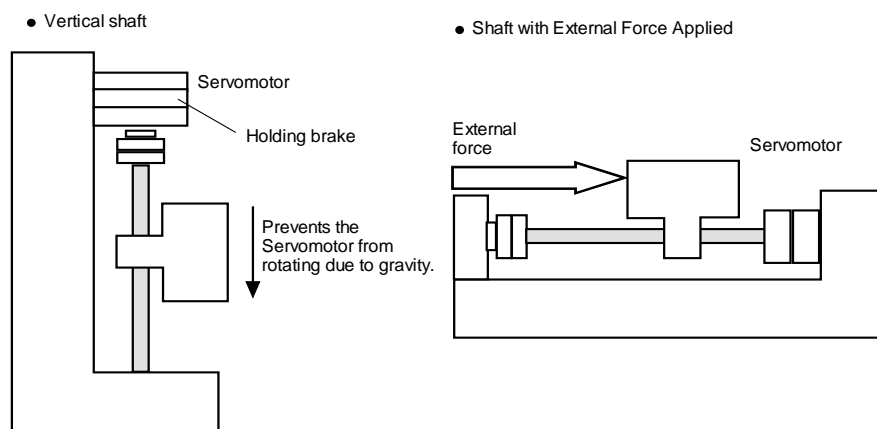

Note: To prevent faulty operation when using gravity or external force, first make sure that both the servomotor and the holding brake work properly. When assured that each operates properly, connect the servomotor to the rest of the equipment to start the trial operation.

The following figure shows wiring for a servomotor with brakes. See [5.4.4 Using the Holding Brake](#) for details on wiring.

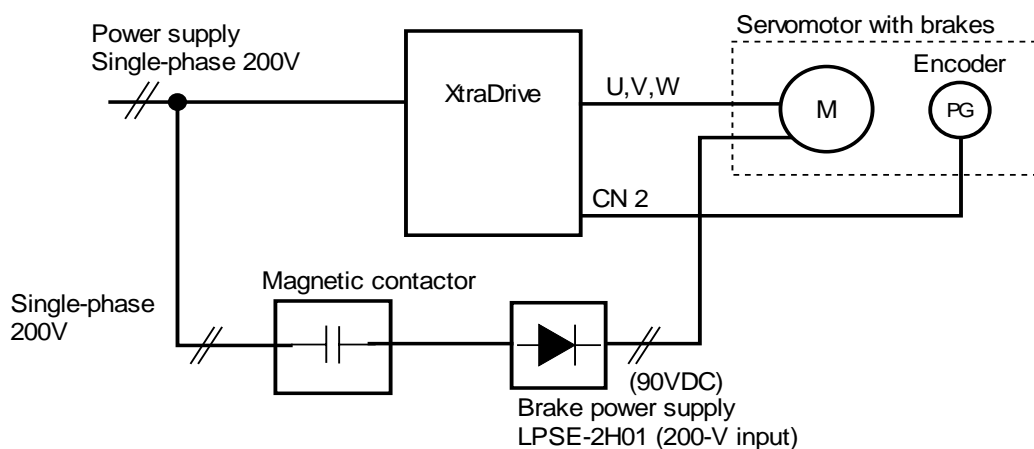

4.2.2. Position Control by Host Controller

If the position control algorithm of the host controller has not been established or finalized, disconnect the servomotor from the equipment before performing a trial operation. This will prevent the servomotor from running out of control and damaging the equipment.

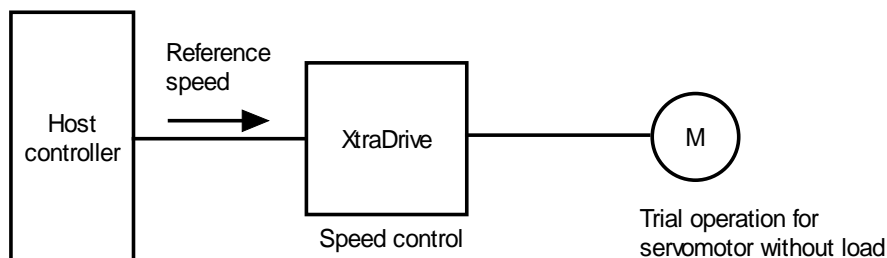

Check servomotor operation as described in the following table.

Controller Reference	Check	Procedure	Description
JOG Operation (Constant Reference Speed Input from Host Controller)	Motor speed	Check motor speed as follows: <ul style="list-style-type: none"> • Use the speed monitor (Un000) on the Panel Operator. • Run the servomotor at low speed. Input a reference speed of 60rpm, for example, to see if the servomotor makes one revolution per second. 	Check the parameter setting at Pn300 to see if the reference speed gain is correct.
Simple Positioning	Number of motor rotations	Input a reference equivalent to one servomotor rotation and visually check to see if the shaft makes one revolution.	Check the parameter setting at Pn201 to see if the number of dividing pulses is correct.
Overtravel (P-OT and N-OT Used)	Whether the servomotor stops rotating when P-OT and N-OT signals are applied	Check to see if the servomotor stops when P-OT and N-OT signals are input during continuous servomotor operation.	Review P-OT and N-OT wiring if the servomotor does not stop.

4.3. Minimum Parameters and Input Signals

This section describes the minimum parameters and input signals required for trial operation.

4.3.1. Parameters

See 7.1.5 *Operation in Parameter Setting Mode* for more details on setting parameters.

Turn power OFF once after changing any parameter except Pn300. The change will not be valid until power is restored.

Basic Parameters

Pn000.1	Function Selection Basic Switches: Control Mode Selection	See 5.3.5
---------	--	-----------

Speed Control

Pn300	Speed Reference	See 5.2.1
Pn201	Using the Encoder Signal Output	See 5.2.3

Position Control

Pn200.0	Position Reference	See 5.2.2
Pn202	Using the Electronic Gear Function (Numerator)	See 5.2.5
Pn203	Using the Electronic Gear Function (Denominator)	See 5.2.5

Changing Servomotor Rotation Direction

If the specified direction differs from the actual direction of rotation, wiring may be incorrect. Recheck the wiring and correct if necessary. Use the following parameter to reverse the direction of rotation.

Pn000.0	Switching Servomotor Rotation Direction	See 5.1.1
---------	---	-----------

4.3.2. Input Signals

Input signal selection settings through parameters can be used to eliminate the need for external short circuits.

Signal Name		Pin Number	Description
/S-ON	Servo ON	CN1-40	See 5.5.2 for more details on turning ON and OFF the servomotor.
P-OT	Forward run prohibited	CN1-42	See 5.1.2 for more details on the overtravel limit switch.
N-OT	Reverse run prohibited	CN1-43	

5. Parameter Settings and Functions

5.1.	Settings According to Device Characteristics.....	5-4
5.1.1.	Switching Servomotor Rotation Direction.....	5-4
5.1.2.	Setting the Overtravel Limit Function	5-5
5.1.3.	Limiting Torque	5-8
5.2.	Settings According to Host Controller.....	5-12
5.2.1.	Speed Reference.....	5-12
5.2.2.	Position Reference	5-14
5.2.3.	Using the Encoder Signal Output	5-20
5.2.4.	Sequence I/O Signals	5-23
5.2.5.	Using the Electronic Gear Function.....	5-24
5.2.6.	Contact Input Speed Control.....	5-29
5.2.7.	Using Torque Control	5-34
5.2.8.	Torque Feed-Forward Function	5-40
5.2.9.	Torque Limiting by Analog Voltage Reference	5-42
5.2.10.	Reference Pulse Inhibit Function (/INHIBIT)	5-44
5.3.	Setting Up the Servo Amplifier	5-45
5.3.1.	Parameters	5-45
5.3.2.	JOG Speed	5-46
5.3.3.	Input Circuit Signal Allocation.....	5-46
5.3.4.	Output Circuit Signal Allocation	5-50
5.3.5.	Control Mode Selection	5-52
5.4.	Setting Stop Functions	5-54
5.4.1.	Adjusting Offset.....	5-54
5.4.2.	Servo OFF Stop Mode Selection	5-55
5.4.3.	Using the Zero Clamp Function.....	5-56
5.4.4.	Using the Holding Brake	5-58
5.5.	Forming a Protective Sequence	5-61
5.5.1.	Using Servo Alarm and Alarm Code Outputs	5-61
5.5.2.	Using the Servo ON Input Signal (/S-ON)	5-63
5.5.3.	Using the Positioning Completed Output Signal (/COIN)	5-64
5.5.4.	Speed Coincidence Output (/V-CMP)	5-65
5.5.5.	Using the Running Output Signal (/TGON)	5-67
5.5.6.	Using the Servo Ready Output Signal (/S-RDY)	5-68
5.5.7.	Using the Warning Output Signal (/WARN).....	5-69
5.5.8.	Handling Power Loss	5-71
5.6.	Selecting a Regenerative Resistor.....	5-72
5.6.1.	External Regenerative Resistor.....	5-73
5.6.2.	Calculating the Regenerative Power Capacity.....	5-74
5.7.	Absolute Encoders	5-78
5.7.1.	Interface Circuit	5-79
5.7.2.	Configuring an Absolute Encoder	5-80
5.7.3.	Absolute Encoder Setup.....	5-81
5.7.4.	Absolute Encoder Reception Sequence	5-84
5.8.	AB Encoders	5-89
5.9.	Configuration of Serial Commands for AB Encoders	5-91
5.9.1.	Position Control	5-91
5.9.1.1.	Defining User Units for Motion Profiles	5-91

5.9.1.3.	Speed Units	5-92
5.9.1.4.	Acceleration Units	5-93
5.9.1.5.	Setting Default Motion Profile Parameters.....	5-94
5.9.1.6.	Profile Speed (Pn2A2, Pn2A3)	5-95
5.9.1.7.	Profile Acceleration (Pn2A4, Pn2A5)	5-95
5.9.1.8.	Jerk Smoothing Time (Pn2A6)	5-95
5.9.1.9.	Quick Stop Deceleration (Pn2A8, Pn2A9)	5-96
5.9.1.10.	Motion End Window (Pn2C0).....	5-96
5.9.2.	Torque Control.....	5-96
5.9.3.	Homing	5-97
5.9.4.	Digital I/O	5-98
5.9.5.	Auto Tuning	5-99
5.10.	Auto Running a User Program.....	5-99

■ Before Reading This Chapter

This chapter describes the use of each CN1 connector I/O signals in the XtraDrive servo amplifier as well as the procedure for setting the related parameters for the intended purposes.

The following sections can be used as references for this chapter.

- List of CN1 I/O signals: See *3.4.3 I/O Signal Names and Functions*.
- CN1 I/O signal terminal layout: See *3.4.2 List of CN1 Terminals*.
- List of parameters: *Appendix D List of Parameters*.
- Parameter setting procedure: *7.1.5 Operation in Parameter Setting Mode*

The CN1 connector is used to exchange signals with the host controller and external circuits.

■ Parameter Configurations

Parameters are comprised of the types shown in the following table. See *Appendix D List of Parameters*.

Type	Parameter Number	Description
Function Selection Constants	Pn000 to Pn007 Pn550 to Pn551	Select basic and application functions such as the type of control or the stop mode used when an alarm occurs.
Servo Gain and Other Constants	Pn100 to Pn11E Pn1A0 to Pn1C0	Set numerical values (speed control). Set numerical values (position control).
Position Control Constants	Pn200 to Pn216 Pn2A2 to Pn2CB	Set position control parameters such as the reference pulse input form gear ratio and application setting.
Speed Control Constants	Pn300 to Pn308	Set speed control parameters such as speed reference input gain and soft start deceleration time.
Torque Control Constants	Pn400 to Pn40A	Set torque control parameters such as the torque reference input gain and forward/reverse torque limits.
Sequence Constants	Pn500 to Pn512 Pn200 to Pn2D2	Set output conditions for all sequence signals and change I/O signal selections and allocations.
Others	Pn600 to Pn601	Specify the capacity for an external regenerative resistor and reserved constants.
Auxiliary Function Execution	Fn000 to Fn014	Execute auxiliary functions such as JOG Mode operation.
Monitor Modes	Un000 to Un00D	Enable speed and torque reference monitoring, as well as monitoring to check whether I/O signals are ON or OFF.
Encoder Selection	Pn190 to Pn193	Encoder type selection

5.1. Settings According to Device Characteristics

This section describes the procedure for setting parameters according to the dimensions and performance characteristics of the equipment used.

5.1.1. Switching Servomotor Rotation Direction

XtraDrive has a Reverse Rotation mode that reverses the direction of servomotor rotation without rewiring. Forward rotation in the standard setting is defined as counterclockwise as viewed from the load.

With the Reverse Rotation mode, the direction of servomotor rotation can be reversed without changing other parameters. Only the direction (+, -) of shaft motion is reversed.

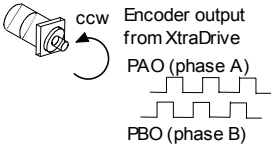
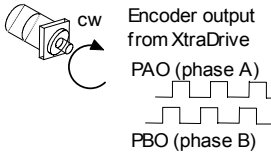
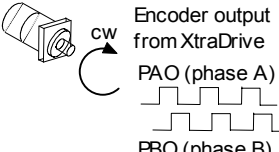
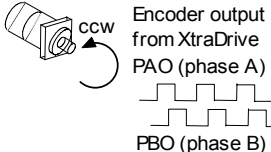
	Standard Setting	Reverse Rotation Mode
Forward Reference		
Reverse Reference		

■ Setting Reverse Rotation Mode

Use the parameter Pn000.0.

Parameter	Signal	Setting	Control Mode
Pn000.0	Direction Selection	Default Setting: 0	Speed/Torque Control, Position Control

Use the following settings to select the direction of servomotor rotation.

Setting	Description
0	Forward rotation is defined as counterclockwise (CCW) rotation as viewed from the load. (Standard setting)
1	Forward rotation is defined as clockwise (CW) rotation as viewed from the load. (Reverse Rotation Mode)

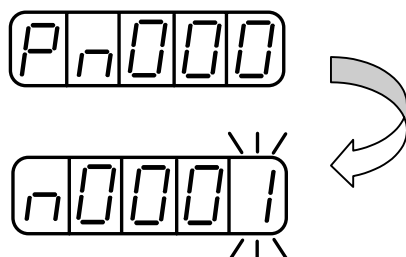

5.1.2. Setting the Overtravel Limit Function

The overtravel limit function forces movable equipment parts to stop if they exceed the allowable range of motion.

■ Using the Overtravel Function

To use the overtravel function, connect the overtravel limit switch input signal terminals shown below to the correct pins of the servo amplifier CN1 connector.

Input ⇒ P-OT CN1-42	Forward Run Prohibited (Forward Overtravel)	Speed/Torque Control, Position Control
Input ⇒ N-OT CN1-43	Reverse Run Prohibited (Reverse Overtravel)	Speed/Torque Control, Position Control

Connect limit switches as shown below to prevent damage of exuipment during linear motion.

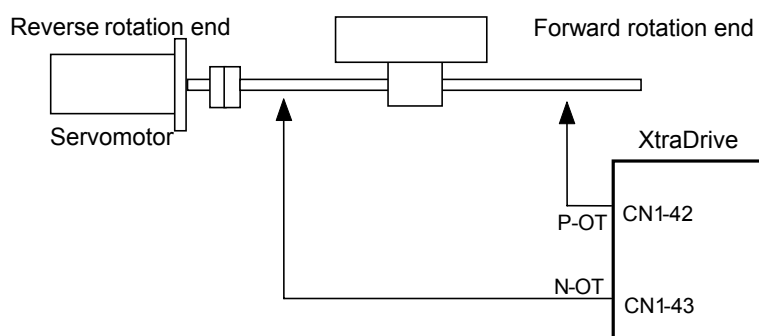

The drive status with an input signal ON or OFF is shown in the following table.

Signal	State	Input Level	Description
P-OT	ON	CN1-42: low	Forward rotation allowed, (normal operation status).
	OFF	CN1-42: high	Forward rotation prohibited (reverse rotation allowed).
N-OT	ON	CN1-43: low	Reverse rotation allowed, (normal operation status).
	OFF	CN1-43: high	Reverse rotation prohibited (forward rotation allowed).

■ Enabling/Disabling Input Signals

Set the following parameters to specify whether input signals are used for overtravel or not. The default setting is “NOT USED.”

Parameter	Signal	Setting	Control Mode
Pn50A.3	P-OT Signal Mapping (Forward Run Prohibit Input Signal)	Default Setting: 8	Speed/Torque Control, Position Control
Pn50B.0	N-OT Signal Mapping (Reverse Run Prohibit Input Signal)	Default Setting: 8	Speed/Torque Control, Position Control

■ Servomotor Stop Mode for P-OT and N-OT Input Signals

Set the following parameters to specify the servomotor Stop mode when P-OT and N-OT input signals are used.

Specify the servomotor Stop mode when either of the following signals is input during servomotor operation.

- Forward run prohibited input (P-OT, CN1-42)
- Reverse run prohibited input (N-OT, CN1-43)
- Set the parameters according to limit switch type (NO or NC).

Parameter	Signal	Setting	Description
Pn50A.3	P-OT Signal Mapping (Forward Run Prohibit Input Signal)	Example: 2	Uses the P-OT input signal to prevent forward rotation. (Forward rotation is prohibited when CN1-42 is open and is allowed when CN1-42 is at 0V).
		Default Setting: 8	Does not use the P-OT input signal to prevent forward rotation. (Forward rotation is always allowed and has the same effect as shorting CN1-42 to 0V).
		Example: B	Inputs the reverse signal from CN1-42 input terminal.
<i>For more options of parameters Pn50A.3 and Pn50B.0 refer to Appendix D.3. Input Signal Selections</i>			
Pn50B.0	N-OT Signal Mapping (Reverse Run Prohibit Input Signal)	Example: 3	Uses the N-OT input signal to prevent reverse rotation. (Reverse rotation is prohibited when CN1-43 is open and is allowed when CN1-43 is at 0V).
		Default Setting: 8	Does not use the N-OT input signal to prevent reverse rotation. (Reverse rotation is always allowed and has the same effect as shorting CN1-43 to 0V).
		Example: C	Inputs the reverse signal from CN1-43 input terminal.

Connection example:

Normally Closed type

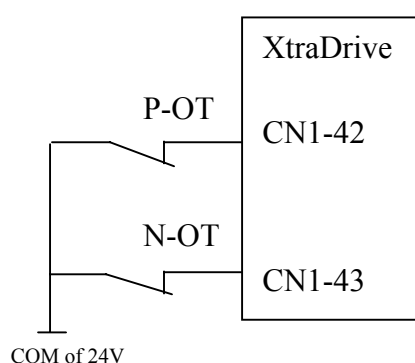

Parameter	Signal	Setting	Control Mode
Pn001.1	Overtravel Stop Mode	Default Setting: 0	Speed/Torque Control, Position Control

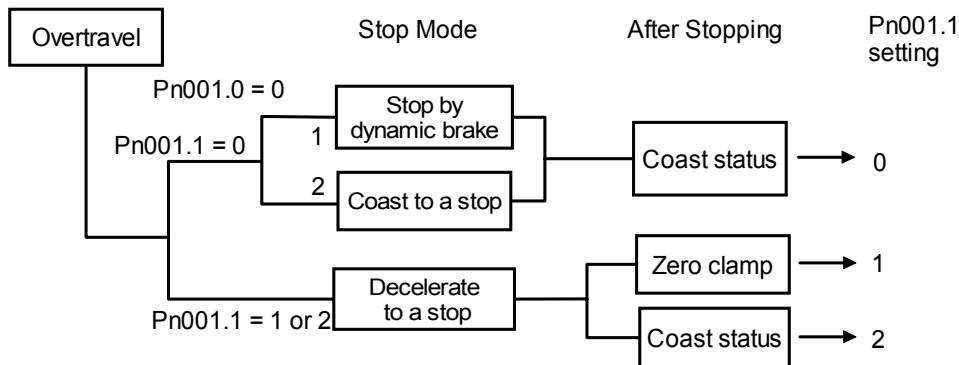

Note: For torque control, the servomotor will be placed in coast status after either decelerating or coasting to a stop (according to the stop mode set in Pn001.0), regardless of the setting of Pn001.1.

Parameter	Signal	Setting	Control Mode
Pn001.1	Overtravel Stop Mode	0	Stops the servomotor the same way as turning the servo OFF (according to Pn001.0).
		1	Decelerates the servomotor to a stop at the preset torque, and then locks the servomotor in Zero Clamp mode. Torque setting: Pn406 Emergency Stop Torque
		2	Decelerates the servomotor to a stop at the preset torque, and puts the servomotor in coast status. Torque setting: Pn406 Emergency Stop Torque

Pn406 specifies the stop torque applied for overtravel when the input signal for prohibiting forward or reverse rotation is used.

The torque limit is specified as a percentage of rated torque.

Parameter	Signal	Setting (%)	Control Mode
Pn406	Emergency Stop Torque (Valid when Pn001.1 is 1 or 2)	Range: 0% to Maximum Torque Default Setting: 800	Speed/Torque Control, Position Control

Stop Mode

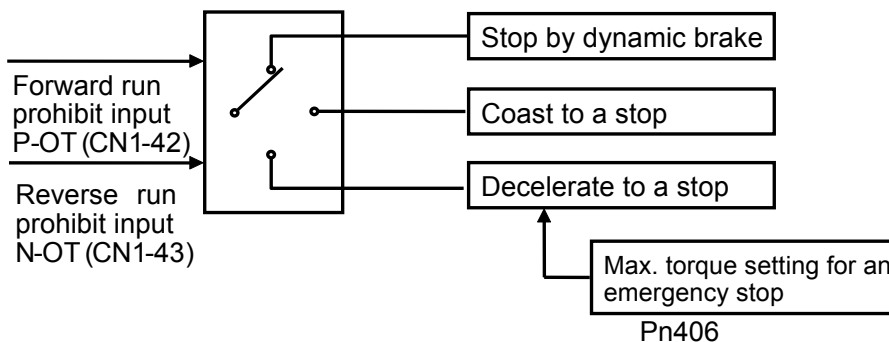

5.1.3. Limiting Torque

The XtraDrive servo amplifier limits torque as follows:

- Level 1: Limits maximum output torque to protect equipment or workpiece.
- Level 2: Limits torque after the servomotor moves the equipment to a specified position (external torque limit).
- Level 3: Always limits output torque rather than speed.
- Level 4: Switches between speed and torque limit.

The application of level 1 and 2 in the torque limit function is described below.

■ Setting Level 1: Internal Torque Limits

Maximum torque is limited to the values set in the following parameters.

Parameter	Signal	Setting (%)	Control Mode
Pn402	Forward Torque Limit	Range: 0 to 800 Default Setting: 800	Speed/Torque Control, Position Control
Pn403	Reverse Torque Limit	Range: 0 to 800 Default Setting: 800	Speed/Torque Control, Position Control

Sets the maximum torque limits for forward and reverse rotation.

Used when torque must be limited due to equipment conditions.

The torque limit function always monitors torque and outputs the signals below when the limit is reached.

Signal	Description
/CLT	Generated when Pn50F.0 allocates an output terminal from SO1 to SO3.
Monitor Mode (Un006)	Output signal monitor

Torque limits are specified as a percentage of the rated torque.

Note: If the torque limit is set higher than the maximum torque of the servomotor, the maximum torque of the servomotor is the limit.

Application Example: Equipment Protection

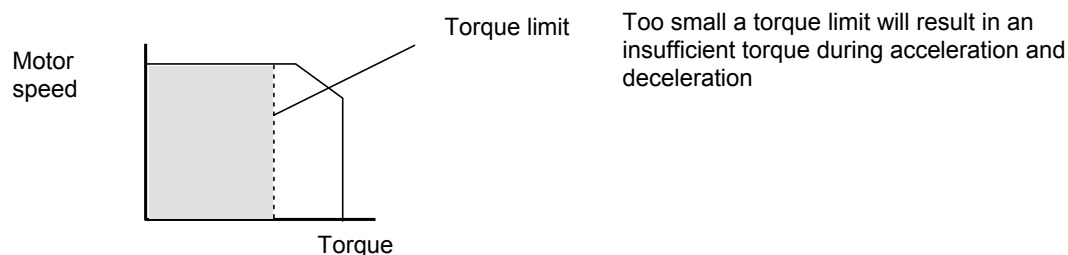

Using the /CLT Signal

The following section describes the use of the contact output signal /CLT as a torque limit output signal.

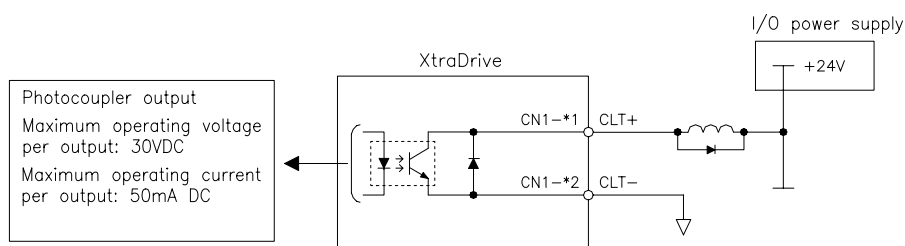

Output ⇒ /CLT CN1-*1	Torque Limit Output	Speed/Torque Control, Position Control
----------------------	---------------------	--

This signal indicates whether the servomotor output torque (current) is being limited.

Status	Conditions	Description
ON	The circuit between CN1-1 and 2 is closed. CN1-1 is at low level.	Servomotor output torque is being limited. (Internal torque reference is greater than the limit setting).
OFF	The circuit between CN1-1 and 2 is open. CN1-1 is at high level.	Servomotor output torque is not being limited. (Internal torque reference is less than the limit setting).

Settings: Pn402 (Forward Torque Limit)
 Pn403 (Reverse Torque Limit)
 Pn404 (Forward External Torque Limit): /P-CL input only
 Pn405 (Reverse External Torque Limit): /N-CL input only

When the /CLT signal is used, the following parameter must be used to select the output signal.

Parameter	Signal	Setting	Control Mode
Pn50F	Output Signal Selections 2	Default Setting: 0000	Speed/Torque Control, Position Control

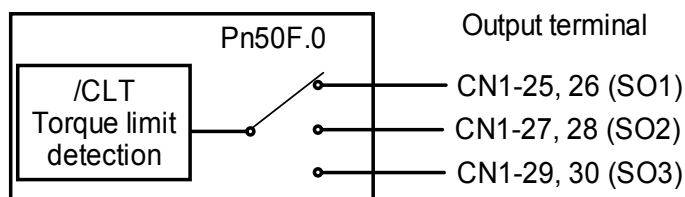

Use the following table to select which terminal will output the /CLT signal.

Parameter	Setting	Output Terminal (CN1-)	
		*1	*2
Pn50F.0	0	—	—
	1	25	26
	2	27	28
	3	29	30

Note: Multiple signals allocated to the same output circuit are output using OR logic. Set other output signals to a value other than the one allocated to the /CLT signal in order to use just the /CLT output signal. See 5.3.4 Output Circuit Signal Allocation.

■ Setting Level 2: External Torque Limit

A contact input signal is used to enable the torque (current) limits previously set in parameters. Torque limits can be set separately for forward and reverse rotation.

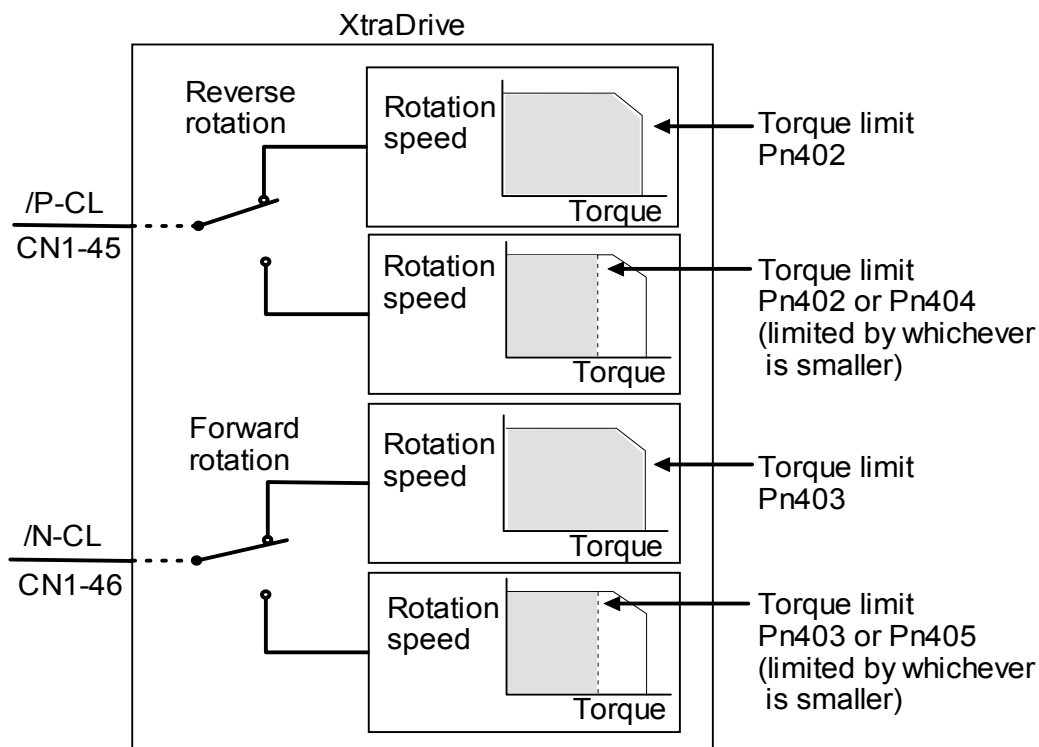

⇒ Input /P-CL CN1-45	Forward External Torque Limit Input	Speed/Torque Control, Position Control
⇒ Output /N-CL CN1-46	Reverse External Torque Limit Input	Speed/Torque Control, Position Control

This is the external torque (current) limit input for forward and reverse rotation.

Check input signal allocation status when using this function (see 5.3.3 *Input Circuit Signal Allocation*). Default settings are given in the table below.

Signal	Signal Status	Comments	Description
/P-CL	CN1-45 at low level when ON	Use forward torque limit.	Limit: Pn404
	CN1-45 at high level when OFF	Do not use forward torque limit. Normal operation.	—
/N-CL	CN1-46 at low level when ON	Use reverse torque limit.	Limit: Pn405
	CN1-46 at high level when OFF	Do not use reverse torque limit. Normal operation.	—

The following output signals and monitor methods are used when torque is being limited.

Signal	Description
/CLT	Generated when Pn50F.0 is allocated to an output terminal from SO1 to SO3.
Monitor Mode (Un006)	—
<ul style="list-style-type: none"> Un005: Numbers 6 and 7 (with default settings) 	Refer to 7.1.6 <i>Operation in Monitor Mode</i> .
<ul style="list-style-type: none"> Un006: Depending on output signal allocation conditions. 	—

Application Examples:

- Forced stop
- Robot holding a workpiece

Parameter	Signal	Setting (%)	Control Mode
Pn404	Forward External Torque Limit	Range: 0 to 800 Default Setting: 100	Speed/Torque Control, Position Control
Pn405	Reverse External Torque Limit	Range: 0 to 800 Default Setting: 100	Speed/Torque Control, Position Control

Set the torque limits when the torque is limited by an external contact input.

Signal	Description
/P-CL (CN1-45) Input	Pn404 torque limit applied.
/N-CL (CN1-46) Input	Pn405 torque limit applied.

See 5.2.9 *Torque Limiting by Analog Voltage Reference*.

Using /P-CL and /N-CL Signals

The procedure for using /P-CL and /N-CL as torque limit input signals is illustrated below.

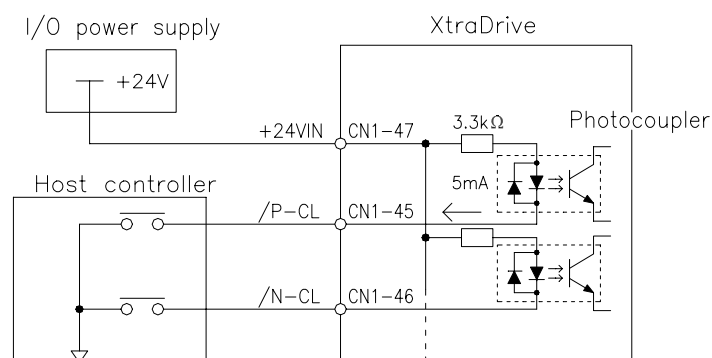

5.2. Settings According to Host Controller

This section describes the procedure for connecting a XtraDrive Series servo to a host controller, including the procedure for setting related parameters.

5.2.1. Speed Reference

Input the speed reference using the input signal: Speed Reference Input. Since this signal has various uses, set the optimal reference input for the system created.

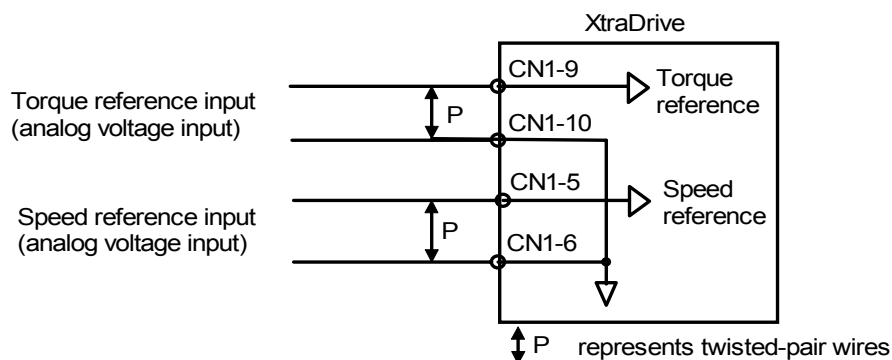

⇒ Input V-REF CN1-5	Speed Reference Input	Speed Control
⇒ Input SG CN1-6	Signal Ground	Speed Control

The above inputs are used for speed control (analog reference). (Pn000.1 = 0, 4, 7, 9, or A.) Always wire for normal speed control.

Refer to 7.1.6 *Operation in Monitor Mode*. The motor speed is controlled in proportion to the input voltage between V-REF and SG.

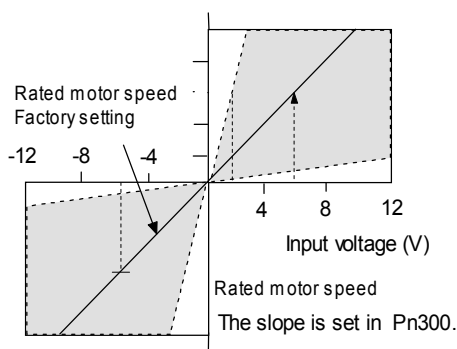

■ Setting Examples

Pn300 = 600: This setting means that 6V is equivalent to the rated motor speed.

Speed Reference Input	Rotation Direction	Motor Speed	SGMAH Servomotor
+6V	Forward rotation	Rated motor speed	3000rpm
+1V	Forward rotation	(1/6) rated motor speed	500rpm
-3V	Reverse rotation	(1/2) rated motor speed	1500rpm

Parameter Pn300 can be used to change the voltage input range.

■ **Input Circuit Example**

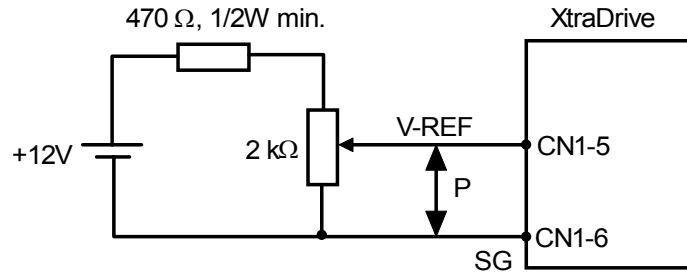

Always use twisted pair cable for noise control.

Recommended variable resistor: Model 25HP-10B manufactured by Sakae Tsushin Kogyo Co., Ltd.

Connect V-REF and SG to the speed reference output terminals on the host controller when using a host controller, such as a programmable controller, for position control.

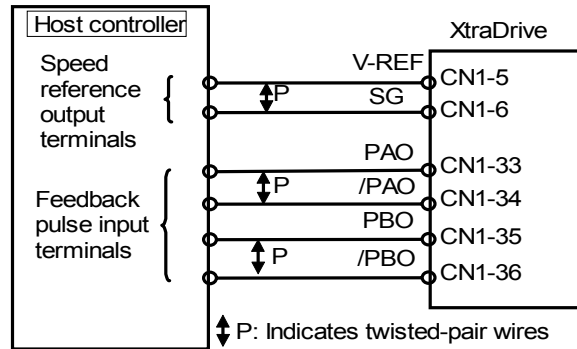

Adjust Pn300 according to the output voltage specifications of the host controller.

Adjust the speed reference input adjustment factor in the following parameter.

Parameter	Signal	Setting	Control Mode
Pn300	Speed Reference Input Adjustment Factor	Range: 150 to 3000 x (0.01V/ rated motor speed)	Speed Control

Set the voltage range for the V-REF speed reference input at CN1-5 according to the host controller and external circuit output range.

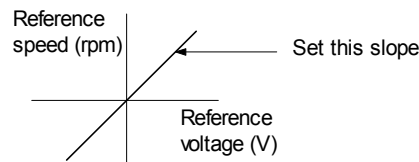

The default setting is adjusted so that a 6V input is equivalent to the rated motor speed of all applicable servomotors.

Note: The maximum allowable voltage to the speed reference input (between CN1-5 and 6) is ± 12 VDC.

Using the /P-CON Signal

⇒ Input P-CON CN1-41	Proportional Control Reference	Speed Control, Position Control
----------------------	--------------------------------	---------------------------------

The /P-CON input signal switches the Speed Control mode from PI (proportional-integral) to P (proportional) control.

Proportional control can be used in the following two ways:

- When an operation is performed by sending speed references from the host controller to the servo amplifier, the host controller can selectively use the P control mode for particular conditions only. This method can prevent the occurrence of overshoot and also shorten settling time.
- If PI control mode is used when the speed reference has a reference offset, the motor may rotate at a very slow speed and fail to stop even if 0 is specified as speed reference. In this case, use the P control mode to stop the motor.

5.2.2. Position Reference

The reference pulse, reference code, and clear inputs are used for the position reference. Since this signal can be used in different ways, set the optimal reference input for the system created.

■ Reference by Pulse Input

Positioning is controlled by entering a reference pulse for a move.

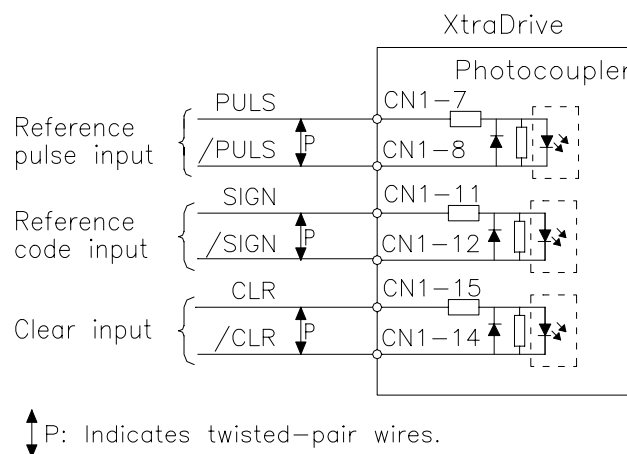

Any of the following forms can be used for the position reference:

- Line-driver output
- +12V open-collector output
- +5V open-collector output

Connection Example 1: Line-driver Output

Applicable line driver: SN75174, manufactured by Texas Instruments Inc., MC3487 or equivalent

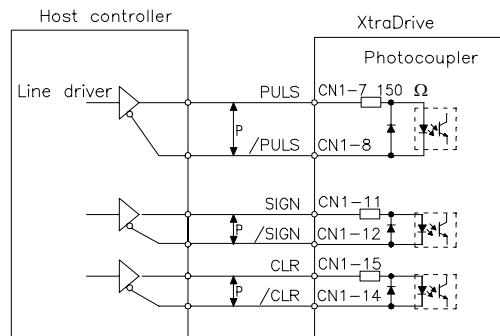

Connection Example 2: Open-collector Output

Set limiting resistor R1 so that input current I falls within the following range:

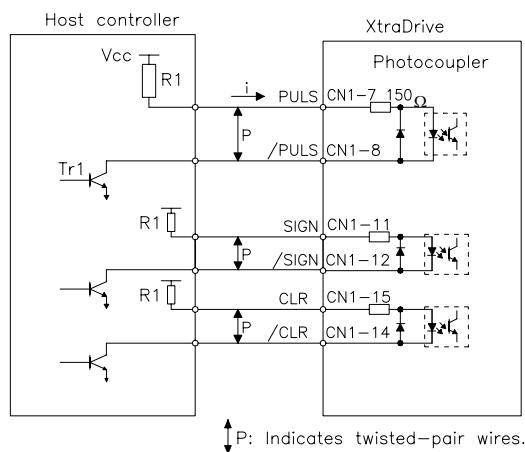

The examples below show how to select the pull-up resistor R1 so that the input current I falls between 7 and 15mA.

Application Examples of $V = IR$	
$R1 = 1k\Omega$ with $V_{cc} = 12V \pm 5\%$	$R1 = 180\Omega$ with $V_{cc} = 5V \pm 5\%$

Note: The following table shows the signal logic for an open-collector output.

Tr1 Output Level	Signal Logic
ON	Equivalent to high-level input
OFF	Equivalent to low-level input

This circuit uses the 12V power supply built into the servo amplifier. The input is not isolated in this case.

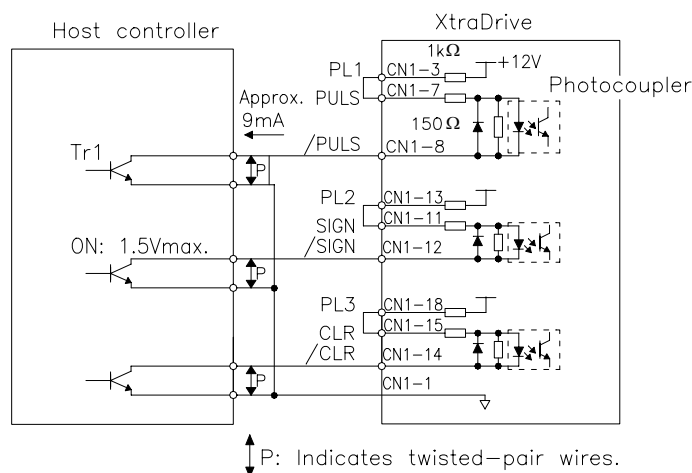

Note: The noise margin of the input signal will decrease if the reference pulse is provided by an open-collector output. Set parameter Pn200.3 to 1 if the position drifts due to noise.

■ Selecting a Reference Pulse Form

Use the following parameters to select the reference pulse form used.

⇒ Input PULS CN1-7	Reference Pulse Input	Position Control
⇒ Input /PULS CN1-8	Reference Pulse Input	Position Control
⇒ Input SIGN CN1-11	Reference Code Input	Position Control
⇒ Input /SIGN CN1-12	Reference Code Input	Position Control

The servomotor only rotates at an angle proportional to the input pulse.

Parameter	Signal	Setting Range	Control Mode
Pn200.0	Reference Pulse Form	Default Setting: 0	Position Control

Set reference pulse form input to the servo amplifier from the host controller.

Note: This function works only with a Pulse Reference, not with a Serial Command.

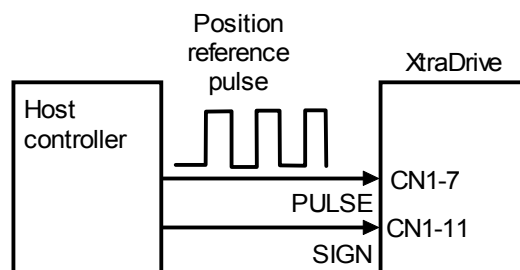

Since the reference pulse form can be selected from among those listed below, set one according to host controller specifications.

Parameter Pn200.0	Reference Pulse Form	Input Pulse Multiplier	Logic	Forward Rotation Reference	Reverse Rotation Reference	
0	Sign + pulse train	---	Positive	PULS (CN1-7) SIGN (CN1-11) High	PULS (CN1-7) SIGN (CN1-11) Low	
1	CW pulse + CCW pulse	---		PULS (CN1-7) Low SIGN (CN1-11)	PULS (CN1-7) SIGN (CN1-11) Low	
2	Two-phase pulse train with 90° phase differential	x1			PULS (CN1-7) SIGN (CN1-11)	PULS (CN1-7) SIGN (CN1-11)
3		x2				
4		x4				
5	Sign + pulse train	---	Negative	PULS (CN1-7) SIGN (CN1-11) Low	PULS (CN1-7) SIGN (CN1-11) High	
6	CW pulse + CCW pulse	---		PULS (CN1-7) High SIGN (CN1-11)	PULS (CN1-7) SIGN (CN1-11) High	
7	Two-phase pulse train with 90° phase differential	x1			PULS (CN1-7) SIGN (CN1-11)	PULS (CN1-7) SIGN (CN1-11)
8		x2				
9		x4				

Input Pulse Multiplier

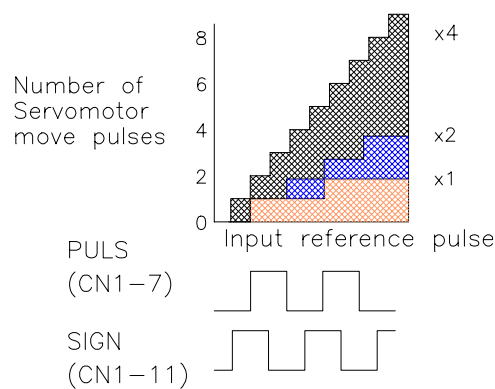

The input pulse multiplier function can be used if the reference pulse is a two-phase pulse train with a 90° phase differential. The electronic gear function can also be used to convert input pulses.

Example of I/O Signal Generation Timing

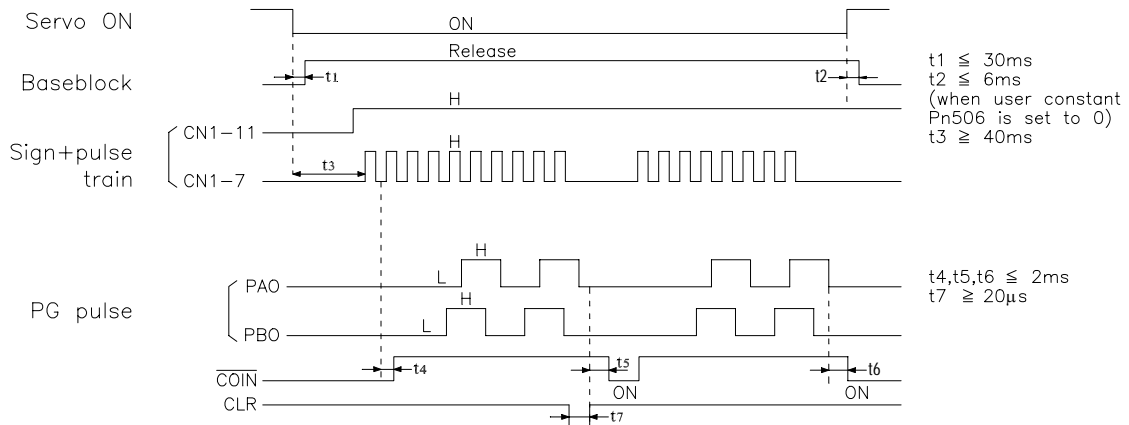

- Note:**
1. For the input pulse to register, the interval from the time the servo ON signal is turned ON until a reference pulse is entered must be a minimum of 40ms.
 2. The error counter clear signal must be ON for at least 20μs.

Reference Pulse Input Signal Timing

Reference Pulse Form	Electrical Specifications	Remarks
Sign + pulse train input (SIGN + PULS signal) Maximum reference frequency: 500kpps (200kpps open-collector output)	<p> $t1, t2 \leq 0.1\mu\text{s}$ $t3, t7 \leq 0.1\mu\text{s}$ $t4, t5, t6 > 3\mu\text{s}$ $\tau \geq 1.0\mu\text{s}$ $(\tau/T) \times 100 \leq 50\%$ </p>	Sign (SIGN) H = Forward reference L = Reverse reference
CW pulse and CCW pulse Maximum reference frequency: 500kpps (200kpps open-collector output)	<p> $t1, t2 \leq 0.1\mu\text{s}$ $t3 > 3\mu\text{s}$ $\tau \geq 1.0\mu\text{s}$ $(\tau/T) \times 100 \leq 50\%$ </p>	—
Two-phase pulse train with 90° phase differential (A phase + B phase) Maximum reference frequency x1: 500kpps (200kpps open-collector output) x2: 400kpps x4: 200kpps	<p> $t1, t2 \leq 0.1\mu\text{s}$ $\tau \geq 1.0\mu\text{s}$ $(\tau/T) \times 100 =$ </p> <p>B phase leads A phase by 90° (Forward reference) B phase leads A phase by 90° (Reverse reference)</p>	Parameter Pn200.0 is used to switch the input pulse multiplier mode.

■ Error Counter Clear Input

The procedure for clearing the error counter is described below.

⇒ Input CLR CN1-15	Clear Input	Position Control
⇒ Input /CLR CN1-14	Clear Input	Position Control

The following occurs when the CLR signal is set to high level.

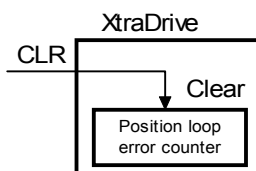

- The error counter inside the servo amplifier is set to 0.
- Position loop control is prohibited.

Use this signal to clear the error counter of the host controller or select the following clear operation through parameter Pn200.1.

Parameter	Signal	Setting Range	Control Mode
Pn200.1	Error Counter Clear Signal Form	Default Setting: 0	Position Control

Select the pulse form for the error counter clear signal CLR (CN1-15).

Pn200.1 Setting	Description	Clear Timing
0	Clears the error counter when the CLR signal goes high. Error pulses do not accumulate as long as the signal remains high.	
1	Clears the error counter on the rising edge of the CLR signal. Clears the error counter only once on the rising edge of the CLR signal.	
2	Clears the error counter when the CLR signal goes low. Error pulses do not accumulate as long as the signal remains low.	
3	Clears the error counter on the falling edge of the CLR signal. Clears the error counter only once on the falling edge of the CLR signal.	

5.2.3. Using the Encoder Signal Output

Encoder output signals are divided inside the servo amplifier and can be output externally. These signals can be used to form a position control loop in the host controller.

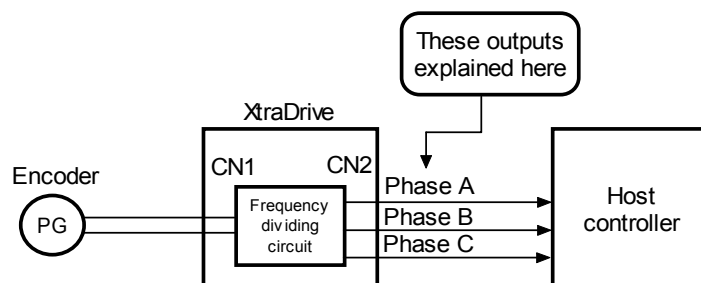

The output circuit is for line-driver output. Connect each signal line according to the following circuit diagram.

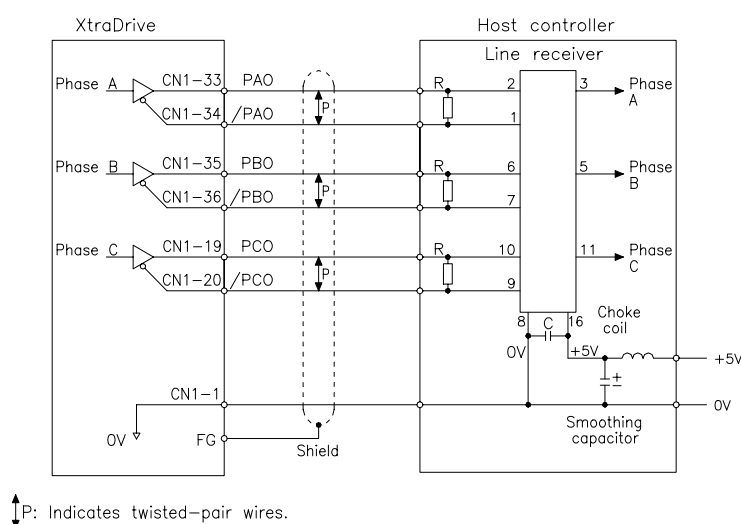

Note: Dividing means converting an input pulse train from the encoder mounted on the servomotor according to the preset pulse density and outputting the converted pulse. The units are pulses per revolution (PPR).

■ I/O Signals

I/O signals are described below.

Output ⇒ PAO CN1-33	Encoder Output Phase A	Speed/Torque Control, Position Control
Output ⇒ /PAO CN1-34	Encoder Output Phase /A	Speed/Torque Control, Position Control
Output ⇒ PBO CN1-35	Encoder Output Phase B	Speed/Torque Control, Position Control
Output ⇒ /PBO CN1-36	Encoder Output Phase /B	Speed/Torque Control, Position Control
Output ⇒ PCO CN1-19	Encoder Output Phase C	Speed/Torque Control, Position Control
Output ⇒ /PCO CN1-20	Encoder Output Phase /C	Speed/Torque Control, Position Control

Divided encoder signals are outputs; therefore always connect these signal terminals when a position loop is formed in the host controller for position control.

Set a dividing ratio using the following parameter: **PG Dividing Ratio** **Pn201**

The dividing ratio setting is not related to the gear ratio setting (Pn202 and 203) for the servo amplifier electronic gear function during position control.

Output Phase Form

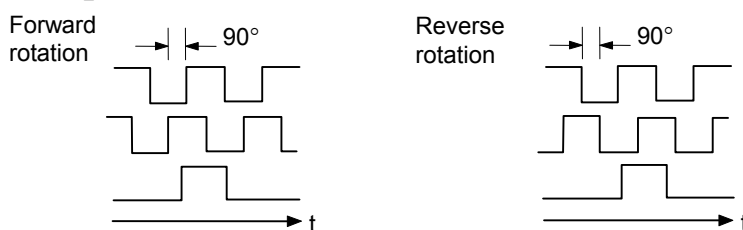

⇒ Input SEN CN1-4	SEN Signal Input	Speed/Torque Control
⇒ Input /SEN CN1-2	Signal Ground	Speed/Torque Control
Output ⇒ PSO CN1-48	Encoder Output Phase S	Speed/Torque Control, Position Control
Output ⇒ /PSO CN1-49	Encoder Output Phase /S	Speed/Torque Control, Position Control
⇒ Input BAT (+) CN1-21	Battery (+)	Speed/Torque Control, Position Control
⇒ Input /BAT (-) CN1-22	Battery (-)	Speed/Torque Control, Position Control

Use SEN to BAT (-) signals for absolute encoders. See 5.7 *Absolute Encoders* for more details.

Output ⇒ SG CN1-1	Signal ground	Speed/Torque Control, Position Control
-------------------	---------------	--

SG: Connect to 0V on the host controller.

IMPORTANT

- **When using the servo amplifier phase C pulse signal to return to the machine origin, always turn the servomotor at least twice before starting the original return operation.** If the configuration of the mechanical system prevents turning the servomotor before the origin return operation, then perform the origin return operation at a servomotor speed of 600rpm or below. The phase C pulse signal may not be correctly applied if the servomotor turns faster than 600rpm.

■ Pulse Divider Setting

Set the pulse dividing ratio in the following parameter:

Parameter	Signal	Setting (PPR)	Control Mode
Pn201	PG Divider	Range: 0 to 65535 Default Setting: 2048	Speed/Torque Control, Position Control

Serial encoder

Set the number of pulses for PG output signals (PAO, /PAO, PBO, /PBO).

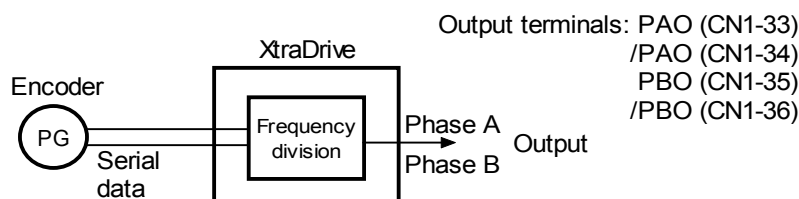

Pulses from the servomotor encoder (PG) are divided by the preset number before being output.

The number of output pulses per revolution is set by this parameter. Set the value using the reference units of the equipment or the controller used.

The setting range varies with the encoder used.

Setting Example

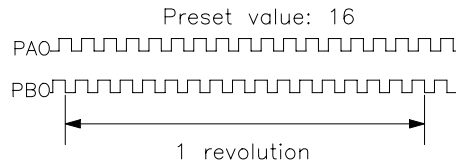

Resolution (Bits)	Number of Encoder Pulses Per Revolution (PPR)	Setting Range
13	2048	16 to 2048
16	16384	16 to 16384
17		

- Note:**1. Turn OFF power once and turn ON again after changing the parameter.
 2. A 13-bit encoder will run at 2048PPR even if the setting at Pn201 is set higher than 2049.

A quad B Encoder - Setting of the pulse-dividing ratio.

$$Pn201 = \frac{PGout \times 65536}{Pn192 \times 4}$$

PGout - number of required out pulses per revolution.

Example: 1000 counts per revolution needed using 8000 counts encoder.

$$Pn201 = \frac{65536 \times PGout}{Counts} = \frac{65536 \times PGout}{Pn192 \times 4} = \frac{65536 \times 1000}{8000} = 8192$$

Note: If a 1:1 ratio (for each incoming and output pulses generated) is required, set Pn201=0.

5.2.4. Sequence I/O Signals

Sequence I/O signals are used to control servo amplifier operation. Connect these signal terminals as required.

■ Input Signal Connections

Connect the sequence input signals as shown below.

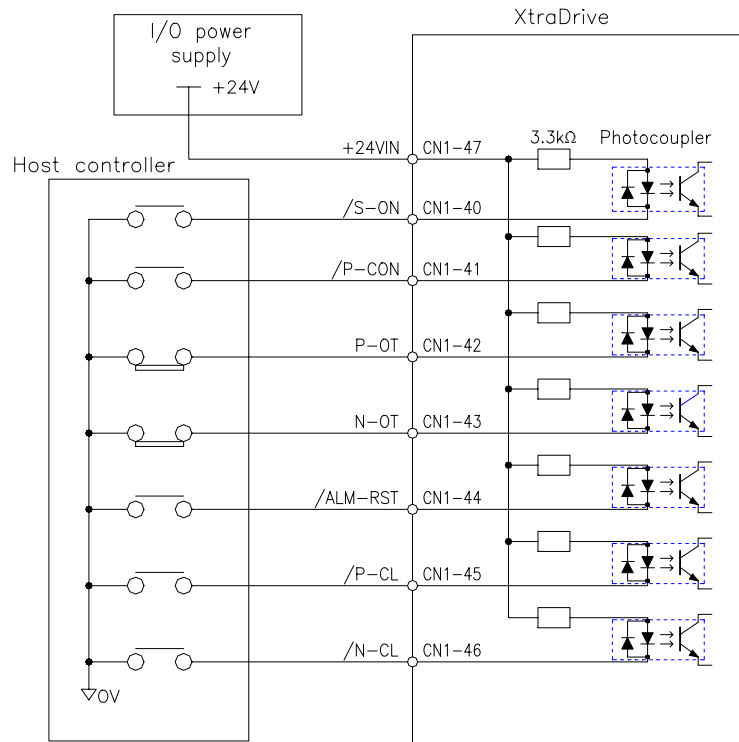

Note: Provide a separate external I/O power supply; the servo amplifier does not have an internal 24V power supply.
 External power supply specifications: 24V ±1 VDC, 50mA minimum.
 Yaskawa recommends using the same type of external power supply as the one used for output circuits.

The function allocation for sequence input signal circuits can be changed.

See 5.3.3 *Input Circuit Signal Allocation* for more details.

⇒ Input +24VIN CN1-47	External I/O Power Supply Input	Speed/Torque Control, Position Control
-----------------------	---------------------------------	--

The external power supply input terminal is common to sequence input signals.

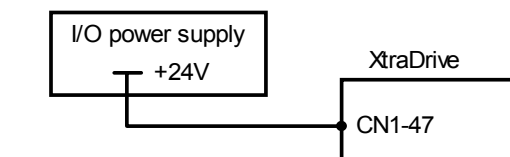

Connect an external I/O power supply

Contact input signals: /S-ON (CN1-40)
 /P-CON (CN1-41)
 P-OT (CN1-42)
 N-OT (CN1-43)
 /ALM-RST (CN1-44)
 /P-CL (CN1-45)
 /N-CL (CN1-46)

■ Output Signal Connections

Connect the sequence output signals as shown in the following figure.

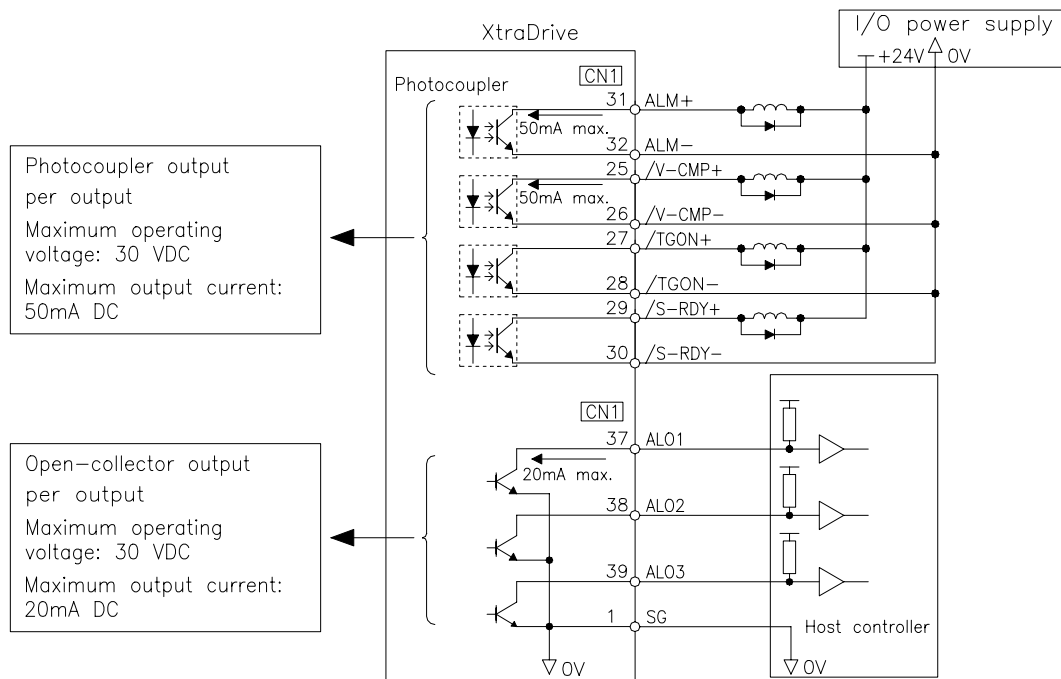

Note: Provide a separate external I/O power supply; the servo amplifier does not have an internal 24V power supply. It is recommended to use the same type of external power supply as the one used for input circuits.

Function allocation for some sequence output signal circuits can be changed.

See 5.3.4 *Output Circuit Signal Allocation* for more details.

5.2.5. Using the Electronic Gear Function

The electronic gear function enables the servomotor travel distance per input reference pulse to be set to any value. It allows the pulses generated by the host controller to be used for control without having to consider the equipment gear ratio or the number of encoder pulses.

When the electronic gear function is not used

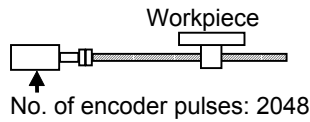

When the electronic gear function is used

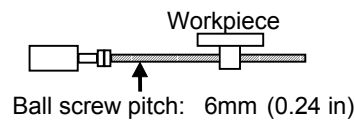

To move a workpiece 10 mm (0.39 in):
 1 revolution is 6 mm. Therefore,
 $10 \div 6 = 1.6666$ revolutions
 2048 x 4 pulses is 1 revolution.
 Therefore, $1.6666 \times 2048 \times 4 = 13653$
 pulses are input as reference.
 The equation must be calculated at the
 host controller.

Equipment conditions and reference
 units must be defined for the electronic
 gear function beforehand.
 To move a workpiece 10 mm (0.39 in):
 Reference unit is $1\mu\text{m}$. Therefore,
 $\frac{10 \text{ mm}}{1\mu\text{m}} = 10000$ pulses

■ Setting the Electronic Gear (for Reference Pulses)

Calculate the electronic gear ratio (B/A) using the following procedure, and set the values in parameters Pn202 and 203.

1. Check equipment specifications related to the electronic gear:
 - Deceleration ratio
 - Ball screw pitch
 - Pulley diameter

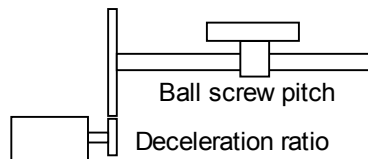

Encoder Type	Number of Encoder Pulses Per Revolution (PPR)	
	Incremental encoder	13-bit
16-bit		16384
17-bit		32768
Absolute encoder	16-bit	16384
	17-bit	32768

Note: The number of bits representing the resolution of the applicable encoder is not the same as the number of encoder signal pulses (A and B phase) output from the servo amplifier.

2. Determine the reference unit used.

A reference unit is the minimum position data unit used to move a load (minimum unit of reference from the host controller).

To move a table in 0.001 mm units

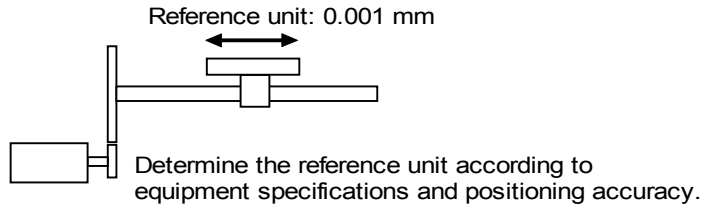

Examples (in mm):

- Reference unit can be 0.1in or 0.01in or 0.01mm or 0.001mm, etc. A reference unit of one pulse moves the load by one reference unit.
- When the reference unit is 1µm
If a reference of 50000 units is input, the load moves 50mm (1.97in) (50000 · 0.001mm = 50mm).

3. Determine the travel distance per load shaft revolution in reference units.

$$\text{Travel distance per load shaft revolution} = \frac{\text{Travel distance per load shaft revolution}}{\text{Reference Unit}}$$

- When the ball screw pitch is 0.20in (5mm) and the reference unit is 0.00004in (0.001mm),

$$\frac{0.20}{0.00004} = 5000 \text{ (reference units)}$$

Ball Screw	Disc Table	Belt and Pulley
<p>Load shaft</p> <p>P: Pitch</p> $1 \text{ figure revolution} = \frac{P}{\text{reference figure unit}}$	<p>Load shaft</p> $1 \text{ figure revolution} = \frac{360^\circ}{\text{reference unit}}$	<p>Load shaft</p> <p>D: Pulley</p> $1 \text{ revolution} = \frac{D}{\text{reference unit}}$

4. Electronic gear ratio is given as: $\left(\frac{B}{A}\right)$

If the gear ratio of the motor and the load shaft is given as: $\frac{m}{n}$ where m is the rotation of the motor and n is the rotation of the load shaft,

$$\text{Electronic gear ratio} \left(\frac{B}{A}\right) = \frac{\text{Number of encoder pulses} \times 4}{\text{Travel distance per load shaft revolution (reference unit)}} \times \frac{m}{n}$$

Note: Make sure the electronic gear ratio satisfies the following condition:

$$0.01 \leq \text{Electronic gear ratio} \left(\frac{B}{A}\right) \leq 100$$

The servo amplifier will not work properly if the electronic gear ratio exceeds this range. In that case, modify either the load configuration or the reference unit.

5. Set the parameters.

Reduce the electronic gear ratio to lower terms so that both A and B are integers smaller than 65535, then set A and B in the respective parameters:

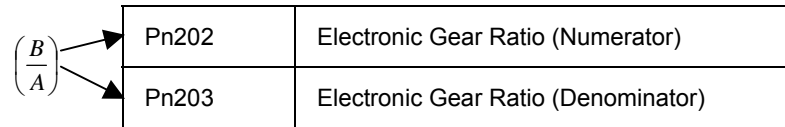

Parameter	Signal	Setting	Control Mode
Pn202	Electronic Gear Ratio (Numerator)	Range: 1 to 65535 Default Setting: 4	Position Control
Pn203	Electronic Gear Ratio (Denominator)	Range: 1 to 65535 Default Setting: 1	Position Control

Set the electronic gear ratio according to equipment specifications.

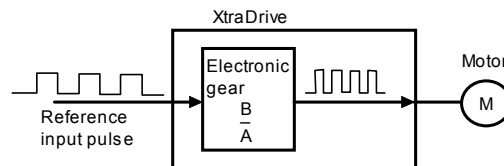

$$\text{Electronic Gear Ratio} = \left(\frac{B}{A}\right) = \frac{\text{Pn202}}{\text{Pn203}}$$

- $B = [(\text{Number of encoder pulses}) \times 4] \times [\text{motor speed}]$
- $A = [\text{Reference units (travel distance per load shaft revolution)}] \times [\text{load shaft revolution speed}]$

■ **Electronic Gear Setting Examples**

The following examples show electronic gear settings for different load mechanisms.

Ball Screws

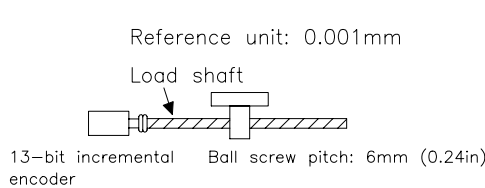

$$\text{Travel distance per load shaft revolution} = \frac{0.24\text{in}}{0.00004\text{in}} = 6000$$

$$\text{Electronic gear ratio} = \left(\frac{B}{A}\right) = \frac{2048 \times 4 \times 1}{6000} = \frac{\text{Pn202}}{\text{Pn203}}$$

Preset Values	Pn202	8192
	Pn203	6000

Circular Tables

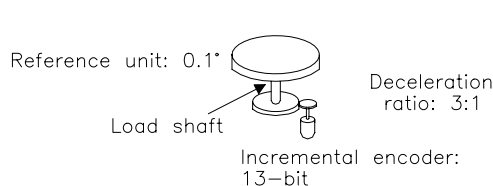

$$\text{Travel distance per load shaft revolution} = \frac{360^\circ}{0.1^\circ} = 3600$$

$$\text{Electronic gear ratio} = \left(\frac{B}{A}\right) = \frac{2048 \times 4 \times 3}{3600} = \frac{\text{Pn202}}{\text{Pn203}}$$

Preset Values	Pn202	24576
	Pn203	3600

Belts and Pulleys

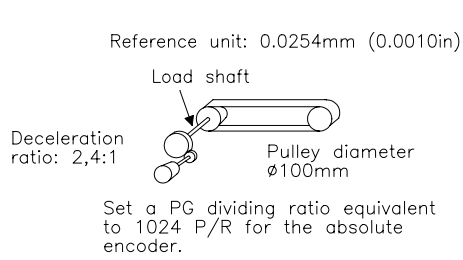

$$\text{Travel distance per load shaft revolution} = \frac{3.1416 \times 4 \text{in}}{0.0010 \text{in}} = 12566$$

$$\text{Electronic gear ratio} = \left(\frac{B}{A}\right) = \frac{16384 \times 4 \times 3}{12566} = \frac{\text{Pn202}}{\text{Pn203}}$$

$$= \frac{196608}{12566} = \frac{20480}{1309}$$

Preset Values	Pn202	20480
	Pn203	1309

■ Control Block Diagram

The following diagram illustrates a control block for position control.

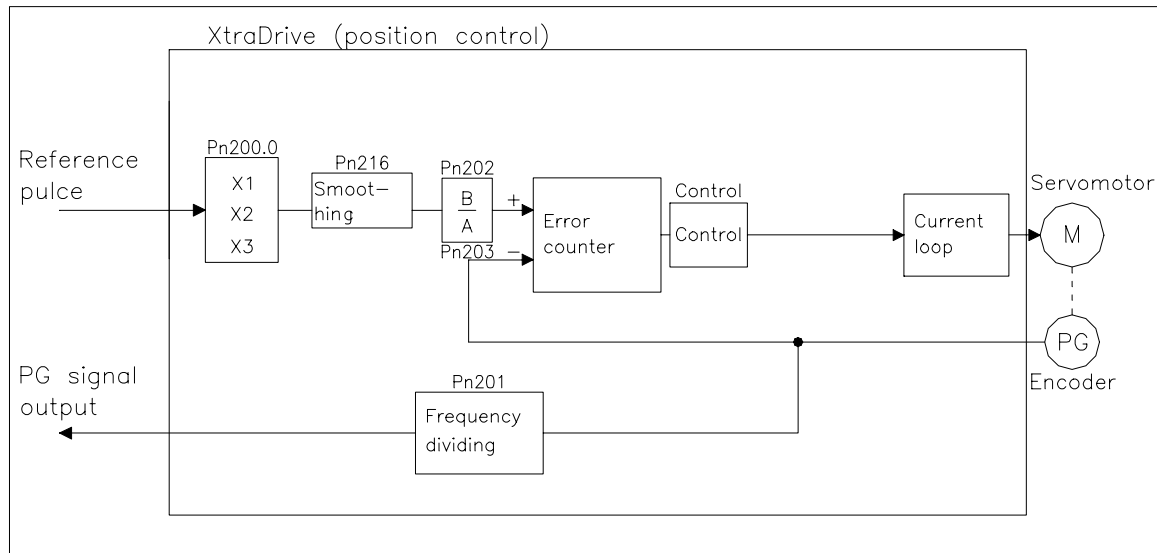

5.2.6. Contact Input Speed Control

This function provides a method for easy speed control. It allows the user to initially set three different motor speeds with parameters, and then select one of the speeds externally using a contact input.

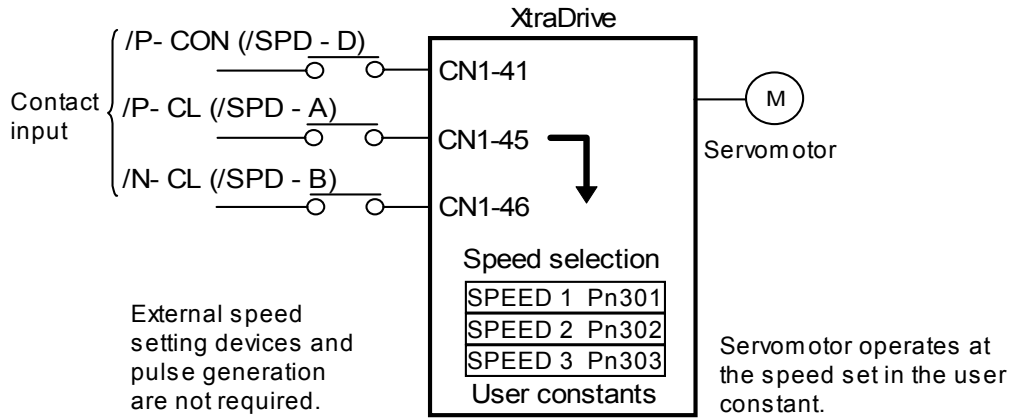

■ Using Contact Input Speed Control

Follow steps 1 to 3 below to use the contact input speed control function.

1. Set contact input speed control as shown below.

Parameter	Signal	Setting	Control Mode
Pn000.1	Control Mode Selection	Default Setting: 0	Speed/Torque Control, Position Control

The speed can be controlled via contact inputs.

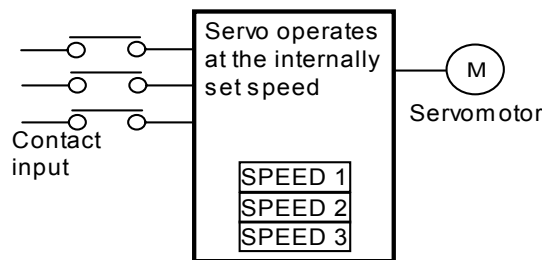

Meanings for the following signals change when the contact input speed control function is used:

Pn000.1 Setting	Description	Input Signal			
0, 2, 7, 8, 9, A, B, C, D	Input contacts. Speed control is function not used.	/P-CON (CN1-41)		Used to switch between P and PI control.	
		/P-CL (CN1-45)		Used to switch between forward external torque limit ON and OFF.	
		/N-CL (CN1-46)		Used to switch between reverse external torque limit ON and OFF.	
3, 4, 5, 6	Input contacts. Speed control function is used.	/P-CON (/SPD-D)	/P-CL (/SPD-A)	/N-CL (/SPD-B)	Speed setting
		Direction of rotation 0: Forward 1: Reverse	0	0	0 reference etc.
			0	1	SPEED 1 (Pn301)
			1	1	SPEED 2 (Pn302)
1	0	SPEED 3 (Pn303)			

Note: 1. 0: OFF (high level); 1: ON (low level)

2. /P-CON, /P-CL and /N-CL functions differ from those in the table above when Pn000.1 is set to 3, 4, 5, or 6. The function is switched automatically when Pn50A. 0 is set to 0.

3. The /SPD-D, /SPD-A, and /SPD-B signals can be used only when signals are allocated to the input circuits. See 5.3.3 *Input Circuit Signal Allocation*.

2. Set the motor speeds using the following parameters.

Parameter	Signal	Setting (rpm)	Control Mode
Pn301	Speed 1 (SPEED 1) (Contact Input Speed Control)	Range: 1 to 10000 Default Setting: 100	Speed Control
Pn302	Speed 2 (SPEED 2) (Contact Input Speed Control)	Range: 1 to 10000 Default Setting: 200	Speed Control
Pn303	Speed 2 (SPEED 2) (Contact Input Speed Control)	Range: 1 to 10000 Default Setting: 300	Speed Control

These parameters are used to set motor speeds when the contact input speed control function is selected. If the setting is higher than the maximum motor speed of the servomotor, then the servomotor will rotate at its maximum speed.

Speed selection input signals /P-CL(SPD-A)(CN1-45) and /N-CL (/SPD-B) (CN1-46) and the rotation direction selection signal /P-CON (/SPD-D)(CN1-41) enable the servomotor to run at the preset speeds.

3. Set the soft start time.

Parameter	Signal	Setting (rpm)	Control Mode
Pn305	Soft Start Acceleration Time	Setting Range: 1 to 10000 Default Setting: 0	Speed Control
Pn306	Soft Start Deceleration Time	Setting Range: 1 to 10000 Default Setting: 0	Speed Control

The servo amplifier internal speed reference controls the speed by applying this acceleration setting.

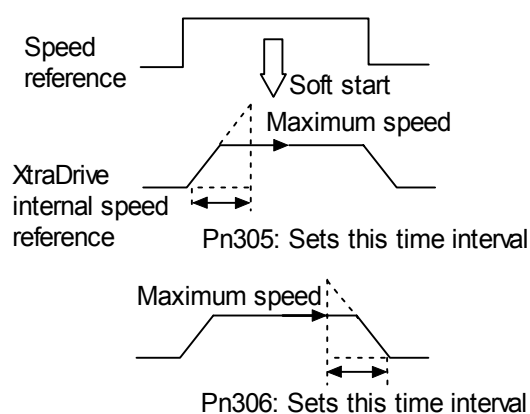

Smooth speed control can be performed by entering a progressive speed reference or using contact input speed control. Set each constant to 0 for normal speed control.

Set each parameter to the following time intervals.

- Pn305: Time interval from when the servomotor starts until it reaches maximum speed.
- Pn306: Time interval from when the servomotor reaches maximum speed until it stops.

■ Operation by Contact Input Speed Control

The following describes operation by contact input speed control.

Start and Stop

The following input signals are used to start and stop the servomotor.

⇒ Input /P-CL CN1-45	Speed Selection 1 (Forward External Torque Limit Input)	Speed/Torque Control, Position Control
⇒ Input /N-CL CN1-46	Speed Selection 2 (Reverse External Torque Limit Input)	Speed/Torque Control, Position Control

Note: Position Control is used here only by Pulse Reference, not by Serial Command

Use the following table when contact input speed control is used.

Contact Signal			Parameter	Selected Speed
/P-CON (/SPD-D)	/P-CL (/SPD-A)	/N-CL (/SPD-B)	Pn000.1	
-	0	0	3	Stopped by an internal speed reference of 0.
			4	Analog speed reference (V-REF) input
			5	Pulse reference input (position control)
			6	Analog torque reference input (torque control)
Direction of rotation 0: Forward 1: Reverse	0	1	3, 4, 5, 6, Common	SPEED 1 (Pn301)
	1	1		SPEED 2 (Pn302)
	1	0		SPEED 3 (Pn303)

- Note:** 1. 0: OFF (high level); 1: ON (low level)
2. Input signals indicated by the horizontal bar (-) are optional.

When contact input speed control is not used, input signals are used as external torque limit inputs.

- Note:** The contact input speed control function is used only when signals are allocated to /SPD-D, /SPD-A, and /SPD-B.

Selection of Rotation Direction

The input signal /P-CON(/SPD-D) is used to specify the direction of servomotor rotation.

⇒ Input /P-CON CN1-41	Speed Selection 1 (Forward External Torque Limit Input)	Speed/Torque Control, Position Control
-----------------------	--	---

- When contact input speed control is used, the input signal /P-CON (/SPD-D) specifies the direction of servomotor rotation.

/P-CON (/SPD-D) Input Level	Signal Logic
0	Forward rotation
1	Reverse rotation

- Note:** 0: OFF (high level); 1: ON (low level)

- When contact input speed control is not used, the /P-CON signal is used for proportional control, zero clamping, and torque/speed control switching.
- Position Control is used here only by Pulse Reference, not by Serial Command.

Example of Contact Input Speed Control Operation

The following example shows operation by contact input speed control. Using the soft start function reduces physical shock when the speed is changed.

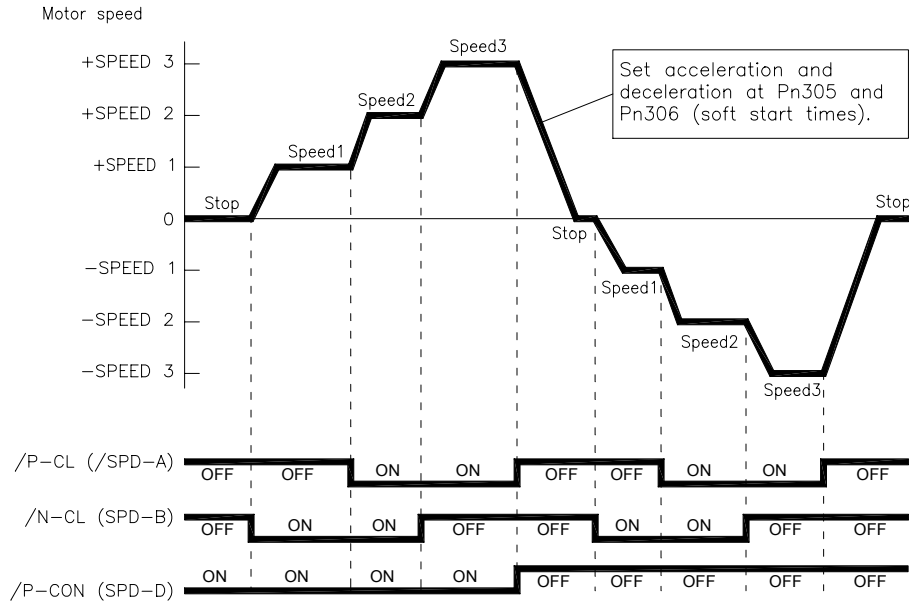

Note: The soft start function is available only when contact input speed control is used with Pn000.1 set to 5. It is not available when a pulse reference input is used. If the Contact Input Speed Control mode is switched to Pulse Reference Input mode while the servomotor is operating at speed 1, speed 2, or speed 3, the servo amplifier will not receive a reference pulse until the positioning completed signal (/COIN) is output. Always start pulse reference output from the host controller after a positioning completed signal is output from the servo amplifier.

Signal Generation Timing for Position Control

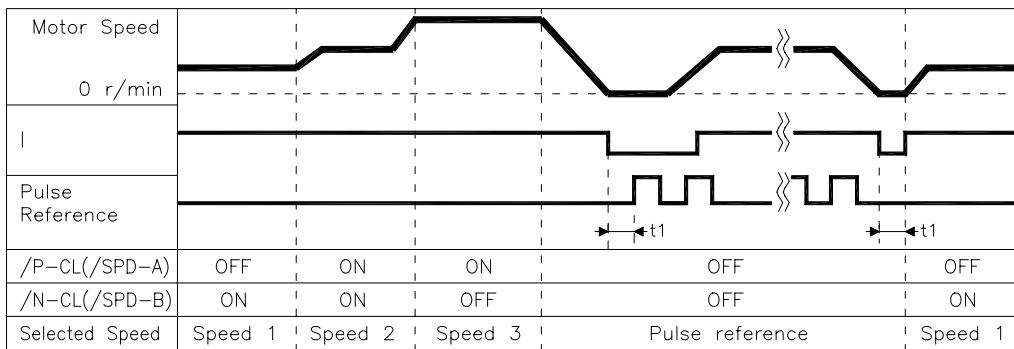

$$t1 > 2ms$$

Note: 1. The above figure illustrates signal generation timing when the soft start function is used.
 2. The value of t1 is not affected by the use of the soft start function. A maximum 2ms delay occurs when the /PC-L(/SPD-A) or /N-CL(/SPD-B) signal is read.

5.2.7. Using Torque Control

The XtraDrive servo amplifier limits torque as shown below.

- Level 1: Limits maximum output torque to protect equipment or workpiece.
- Level 2: Limits torque after the servomotor moves the equipment to a specified position (external torque limit).
- Level 3: Controls torque output rather than speed output.
- Level 4: Switches between speed and torque control.

The following describes uses for levels 3 and 4 in the torque control function.

■ Torque Control Selection

Set the following parameter to select the type of control described in levels 3 and 4.

Parameter	Signal	Setting	Control Mode
Pn000.1	Control Method Selection	Default Setting: 0	Speed/Torque Control, Position Control

For further explanation of settings, see *Appendix D.2 Switches*.

A torque reference is entered from the host controller to the servo amplifier in order to control torque.

Application Examples

- Tension control
- Pressure control

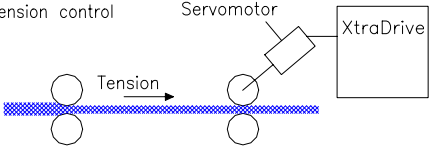
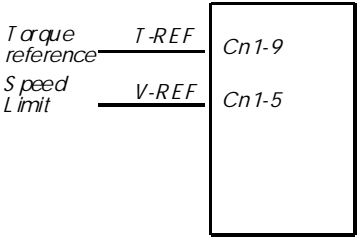
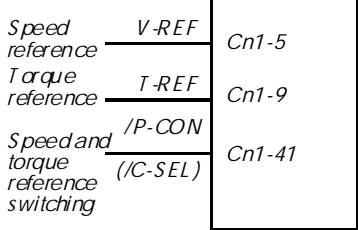
Pn000.1	Control Mode							
<p>2</p> <p>Torque Control This is a dedicated Torque Control mode.</p> <ul style="list-style-type: none"> • A torque reference is input from T-REF (CN1-9). • Speed reference input V-REF (CN1-5) cannot be used for speed control if Pn002.1 is set to 1. • Parameter Pn407 can be used for maximum speed control. <p>Application Example Tension control</p> 		<p style="text-align: right;"><i>Servo amplifier</i></p> 						
<p>9</p> <p>Torque Control <-> Speed Control (Analog Reference) Switches between torque and speed control</p> <ul style="list-style-type: none"> • V-REF (CN1-5) inputs a speed reference or speed limit. • T-REF (CN1-9) inputs a torque reference, torque feed-forward reference or torque limit depending on the control mode. • /P-CON (/C-SEL)(CN1-41) is used to switch between torque and speed control. <table border="1" data-bbox="405 1227 895 1312"> <thead> <tr> <th>CN1-41 State</th> <th>Selects</th> </tr> </thead> <tbody> <tr> <td>Open</td> <td>Torque Control</td> </tr> <tr> <td>0V</td> <td>Speed Control</td> </tr> </tbody> </table> <p>Torque Control: When /P-CON (/C-SEL) is OFF</p> <ul style="list-style-type: none"> • The T-REF reference controls torque. • V-REF can be used to limit servomotor speed when Pn002.1 is set to 1. V-REF voltage (+) limit servomotor speed during forward and reverse rotation. • Parameter Pn407 can be used to limit the maximum servomotor speed. 	CN1-41 State	Selects	Open	Torque Control	0V	Speed Control		<p style="text-align: right;"><i>Servo amplifier</i></p> 
CN1-41 State	Selects							
Open	Torque Control							
0V	Speed Control							

Pn000.1	Control Mode			
9	Speed Control: When /P-CON (/C-SEL) is ON Set the parameter Pn002.0 as shown below.			
	Parameter Pn002.0 State	Speed Reference Input (V-REF) (CN1-5,6)	Torque Reference Input (T-REF) (CN1-9,10)	Comments
	0	Speed Control Speed Reference Cannot be used.		
	1	Torque limit speed control by analog voltage reference		See 5.2.9 <i>Speed Feed-Forward Function</i> for more details on torque limit speed control by analog voltage reference.
		Speed Reference	Torque Limit	
	2	Speed control with torque feed-forward Speed reference Torque feed-forward		See 5.2.8 <i>Torque Feed-Forward Function</i> for more details on torque feed-forward speed control.
8	Position Control ⇔ Torque Control Can be used to switch between speed (contact reference) and torque control.			
	<ul style="list-style-type: none"> • /P-CON (/C-SEL)(CN1-41) is used to switch control. 			
	CN1-41 State	Selects		
	Open	Position Control		
	0V	Torque Control		
6	Speed Control (Contact Reference) ⇔ Torque Control Can be used to switch between speed (contact reference) and torque control.			
	<ul style="list-style-type: none"> • /P-CON (/C-SEL)(CN1-45) and /N-CL (SPD-B)(CN1-46) are used to switch control. 			
	Parameter /P-CL (/SPD-A) CN1-45 State	Parameter /N-CL (/SPD-B) CN1-46 State		
	0	0	Torque Control	
	0	1	Speed Control	
	1	1	(Contact reference)	
	1	0		

Note: Input signal /C-SEL can be used only when a signal is allocated to the input circuit. See 5.3.3 *Input Circuit Signal Allocation*.

■ **Input Signals**

Torque Reference Inputs

The following input signals are used for torque control.

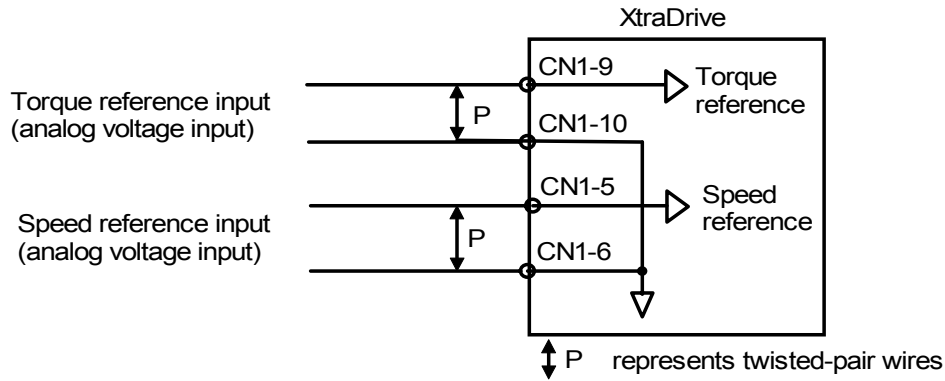

⇒ Input T-REF CN1-9	Torque Reference Input	Speed/Torque Control
⇒ Input SG CN1-10	Signal Ground for the Torque Reference Input	Speed/Torque Control

These signals are used when torque control is selected.

Servomotor torque is controlled so that it is proportional to the input voltage between T-REF and SG.

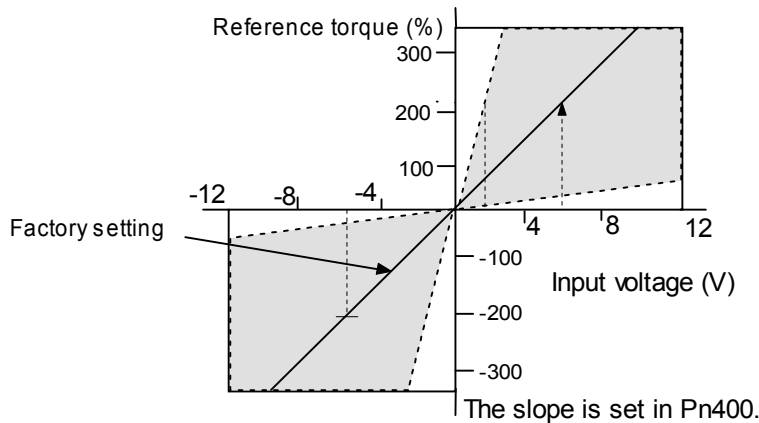

■ **Default Settings**

Parameter Pn400 establishes the voltage level that applies rated torque.

For example:

With Pn400 = 30	
Vin (V)	Resulting Applied Torque
+3	100% of rated torque in forward direction
+9	300% of rated torque in forward direction
-0.3	10% of rated torque in reverse direction

■ Example of an Input Circuit

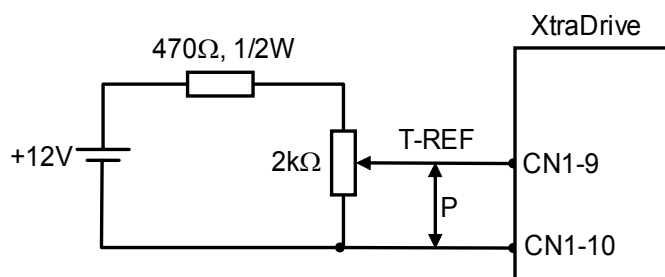

Note: Always use twisted pair cables for noise control.

Speed Reference Inputs

Refer to Section 5.2.1.

Using the /P-CON Signal

⇒ Input /P-CON CN1-41	Proportional Control Reference, etc.	Speed/Torque Control, Position Control
-----------------------	--------------------------------------	--

The function of the input signal /P-CON varies with the setting applied to Pn000.1.

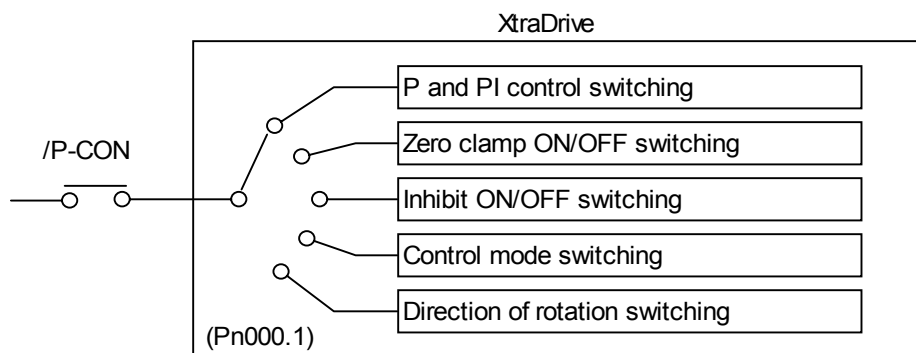

Pn000.1 Setting	/P-CON Function
0, C, D	Switches between P (proportional) and PI (proportional-integral) control.
2	Not used.
3, 4, 5, 6	Switches the direction of rotation in Contact Input Speed Control mode.
7, 8, 9	Switches the control mode.
A	Turns ON/OFF zero clamp.
B	Turns inhibit ON/OFF.

Note: The /P-CON signal function switches automatically when Pn50A.0 is set to 0.

■ Torque Control Parameter

The following parameter is used for torque control. Set the parameter according to requirements of the servo system that is used.

Parameter	Signal	SETTING (0.1V X RATED TORQUE)	Control Mode
Pn400	Torque Reference Input Gain	Setting Range: 10 to 100 Default Setting: 30	Speed/Torque Control

This parameter sets the voltage range for torque reference input T-REF (CN1-9) depending on the output range of the host controller or external circuit.

The default setting is 30, so the rated torque output is equal to 3V (30×0.1).

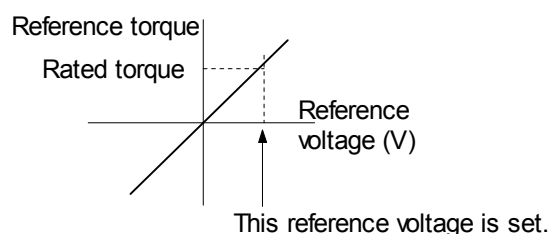

Pn002.1 Setting	Description
0	Uses speed limit set by Pn407 (internal speed limit function).
1	Uses V-REF (Cn1-5 and -6) as external speed limit input and sets speed limit by voltage, which are input to V-REF and Pn300 (external speed limit function).

Internal Speed Limit Function

Parameter	Signal	Setting (rpm)	Control Mode
Pn407	Speed Limit during Torque Control	Setting Range: 0 to 10000 Default Setting: 10000	Speed/Torque Control

This parameter sets a motor speed limit when torque control is selected. It is used to prevent excessive equipment speed during torque control.

Since the speed limit detection signal /VLT functions the same in torque control as the /CLT signal, see 5.1.3 *Limiting Torque*, where the /CLT signal is described.

Torque Control Range

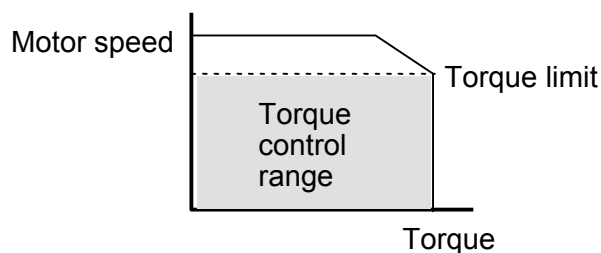

The maximum speed of the servomotor will be used if Pn407 is set to a value higher than the maximum speed of the servomotor.

External Speed Limit Function:

This function sets the voltage range for speed reference input V-REF (CN1-5) according to the output range of the host controller or external circuit.

When the default setting (600) is multiplied by 0.01V, the result (6V) corresponds to the rated motor speed.

Parameter	Signal	Setting	Control Mode
Pn300	Speed Reference Input Gain	Setting Range: 150 to 3000 Default Setting: 600	Speed/Torque Control

The default setting is $6V =$ the rated motor speed.

Principle of Speed Limit

When the control speed range is exceeded, the torque, which is inversely proportional to the difference between the speed limit and the actual speed, is fed back in order to return the system to a level within the control speed range. In effect, the actual motor speed limit depends on the load condition.

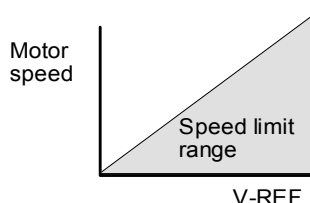

5.2.8. Torque Feed-Forward Function

The torque feed-forward function is used only in speed control (analog reference). This function is used to:

- Shorten positioning time
- Differentiate a speed reference at the host controller to generate a torque feed-forward reference
- Input this reference together with the speed reference to the servo amplifier

Too high a torque feed-forward value will result in an overshoot or an undershoot. To prevent this, set the optimal value while closely observing the system response.

Connect a speed reference signal to V-REF (CN1-5 and 6) and a torque feed-forward reference signal to T-REF (CN1-9 and 10).

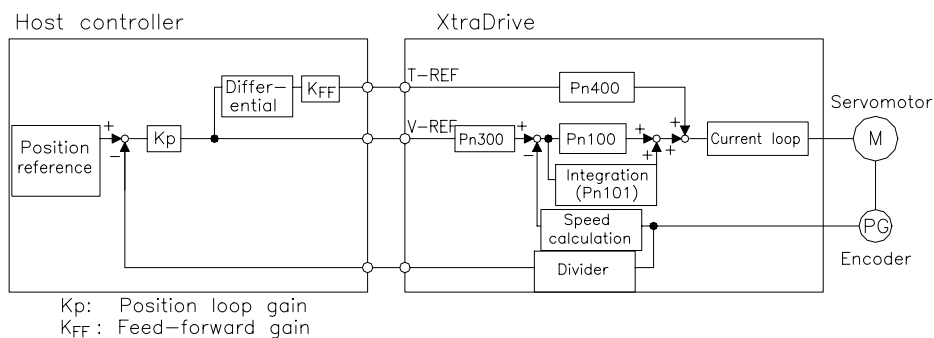

■ Using the Torque Feed-Forward Function

To use the torque feed-forward function, set the following parameter to 2.

Parameter	Signal	Setting	Control Mode
Pn002.0	Speed Control Option (T-REF Terminal Allocation)	Default Setting: 0	Speed/Torque Control

This setting enables the torque feed-forward function.

Pn002.0 Setting	T-REF Function
0	None.
1	T-REF terminal used for external torque limit input.
2	T-REF terminal used for torque feed-forward input.

The torque feed-forward function cannot be used with the torque limiting by analog voltage reference function described in 5.2.9 *Torque Limiting by Analog Voltage Reference*.

■ Setting

Torque feed-forward is set using parameter Pn400.

The default setting at Pn400 is 30. If, for example, the torque feed-forward value is $\pm 3V$, then the torque is limited to $\pm 100\%$ of the rated torque.

Parameter	Signal	Setting (0.1V/Rated Torque)	Control Mode
Pn400	Torque Reference Input Adjustment Factor	Setting Range: 0 to 100 Default Setting: 30	Speed/Torque Control

5.2.9. Torque Limiting by Analog Voltage Reference

Torque limiting by analog voltage reference limits the torque by assigning a torque analog voltage to the T-REF terminal (CN1-9 and 10). It cannot be used for torque control because the torque reference input terminal T-REF is used as an input terminal.

The torque is limited at the forward run side when the P-CL signal turns ON and at the reverse run side when the N-CL signal turns ON.

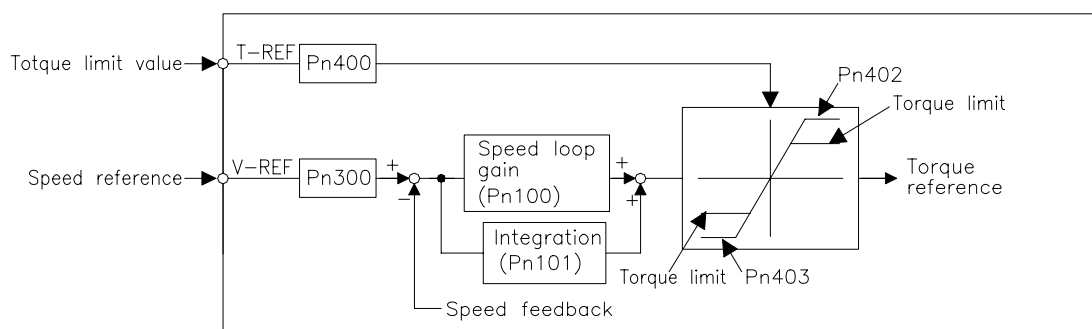

■ Using Torque Limiting by Analog Voltage Reference

To use this function, set the following parameter to 3:

Parameter	Signal	Setting (rpm)	Control Mode
Pn002.0	Speed Control Option (T-REF Terminal Allocation)	Default Setting: 0	Speed Control, Position Control

This parameter can be used to enable torque limiting by analog voltage reference.

Pn002.0 Setting	T-REF Function
0	None.
1	T-REF terminal used for external torque limit input.
2	T-REF terminal used for torque feed-forward input.
3	T-REF terminal used for external torque limit input when P-CL and N-CL are valid.

This function cannot be used with the torque feed-forward function described in 5.2.8 *Torque Feed-Forward Function*.

To use this function, verify how input signals have been allocated. (Refer to section 5.3.3 *Input Circuit Signal Allocation*). The following table outlines factory default settings.

Input Signal	Signal Level	Description	Comments
/P-CL	CN1-45 is at "L" level when ON	Torque is limited at the forward run side.	Limit value: either Pn404 or T-REF input, whichever is smaller.
	CN1-45 is at "H" level when OFF	Torque is not limited at the forward run side. Normal Operation	—
/N-CL	CN1-46 is at "L" level when ON	Torque is limited at the reverse run side.	Limit value: either Pn405 or T-REF input, whichever is smaller.
	CN1-46 is at "H" level when OFF	Torque is not limited at the forward run side. Normal operation.	—

■ Setting

The torque limit is set using parameter Pn400.

The default setting for Pn400 is 30. If, for example, the torque limit is $\pm 3V$, then torque is limited to 100% of the rated torque. (A torque value higher than 100% torque is clamped at 100%.)

Parameter	Signal	Setting (0.1V/Rated Torque)	Control Mode
Pn400	Torque Reference Input Adjustment Factor	Setting Range: 0 to 100 Default Setting: 30	Speed/Torque Control

When either the P-CL or the N-CL signal is turned ON, the following torque limits become valid simultaneously.

Parameter	Signal	Setting (0.1V/Rated Torque)	Control Mode
Pn404	Forward Run Side External Torque Limit	Setting Range: 0 to 800 Default Setting: 100	Speed/Torque Control, Position Control
Pn405	Reverse Run Side External Torque Limit	Setting Range: 0 to 800 Default Setting: 100	Speed/Torque Control, Position Control

5.2.10. Reference Pulse Inhibit Function (/INHIBIT)

This function inhibits the servo amplifier from counting input reference pulses during position control. The servomotor remains locked (clamped) while the function is in use. The /P-CON(/INHIBIT) signal is used to enable or disable the function.

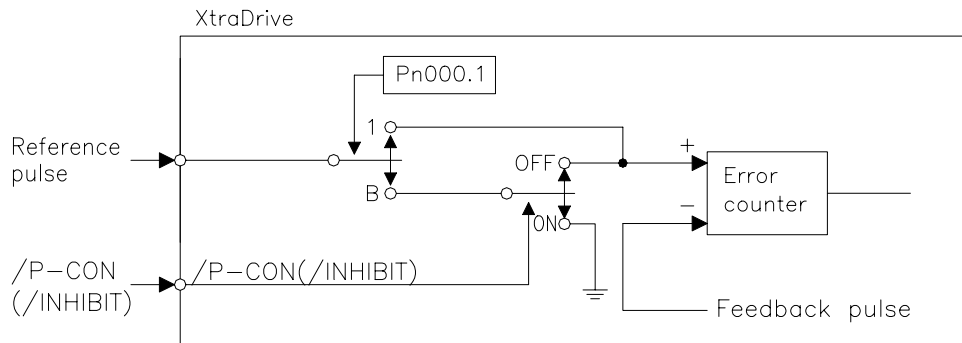

■ Using Reference Pulse Inhibit Function (/INHIBIT)

To use the inhibit function, set the parameter as shown below.

Parameter	Signal	Setting (rpm)	Control Mode
Pn000.1	Control Method Selection	Default Setting: 0	Position Control

The following settings enable the inhibit function.

Pn000.1 Setting	Description	
C	Enables the inhibit function. Always counts reference pulses.	
B	Enables the inhibit function. The /P-CON (/INHIBIT) signal is used to enable or disable the inhibit function.	
	/P-CON (/INHIBIT)	Description
	OFF	Counts reference pulses.
ON	Prohibits the servo amplifier from counting reference pulses. The servomotor remains locked.	

Note: Parentheses () around an /INHIBIT signal indicate that a signal has been allocated to the input circuit. See 5.3.3 *Input Circuit Signal Allocation* for more details.

■ Relationship between Inhibit Signal and Reference Pulses

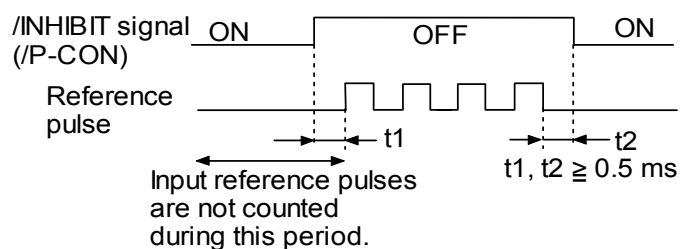

5.3. Setting Up the Servo Amplifier

This section describes the procedure of setting parameters to operate the XtraDrive servo amplifier.

5.3.1. Parameters

The XtraDrive Series servo amplifier provides many functions and has parameters that allow the user to specify functions and perform fine adjustments.

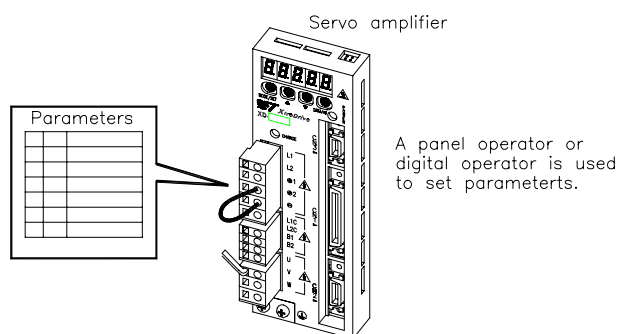

Parameters are divided into the following three groups.

Parameter	Function
Pn000 to Pn601	Specify servo amplifier functions, set servo gains, etc.
Fn000 to Fn012	Execute auxiliary functions such as JOG mode operations and origin searches.
Un000 to Un00D	Enable monitoring the motor speed and torque reference on the panel display.

Note: Appendix B shows a list of parameters provided for reference. See 7.1.5 *Operation in Parameter Setting Mode* for more details on the parameter setting procedure.

5.3.2. JOG Speed

Use the following parameter to set or modify motor speed when operating the servomotor from a panel or digital operator.

Parameter	Signal	Setting (rpm)	Control Mode
Pn304	JOG Speed	Setting Range: 0 to 10000 Default Setting: 500	Speed/Torque Control, Position Control

If the setting is higher than the maximum motor speed of the servomotor, then the servomotor will rotate at its maximum speed.

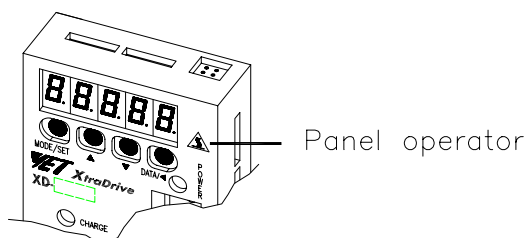

5.3.3. Input Circuit Signal Allocation

The functions allocated to sequence input signal circuits can be changed. CN1 connector input signals are allocated with the default settings as shown in the following table.

CN1 Connector Terminal Numbers	Input Terminal Name	Default Setting	
		Symbol	Name
40	SI0	/S-ON	Servo ON
41	SI1	/P-CON	(Proportional control reference) *
42	SI2	P-OT	Forward run prohibit
43	SI3	N-OT	Reverse run prohibit
44	SI4	/ALM-RST	Alarm reset
45	SI5	/P-CL	(Forward current limit) *
46	SI6	/N-CL	(Reverse current limit) *

Note: * The functions of these input signals are automatically switched according to the setting for parameter Pn000.1 as long as Pn50A.0 is set to 0.

The following parameter is used to enable input signal allocation.

Parameter	Signal	Setting	Control Mode
Pn50A.0	Input Signal Allocation Mode	Default Setting: 0	Speed/Torque Control, Position Control

Pn50A.0 Setting	Description
0	Default setting for sequence input signal allocation.
1	Enables any sequence input signal settings.

Note: The default setting for parameter Pn50A.0 is 0. Functions and applications in this manual are generally described for the factory defaults.

■ Input Signal Allocation

The following signal can be allocated when Pn50A.0 is set to 1.

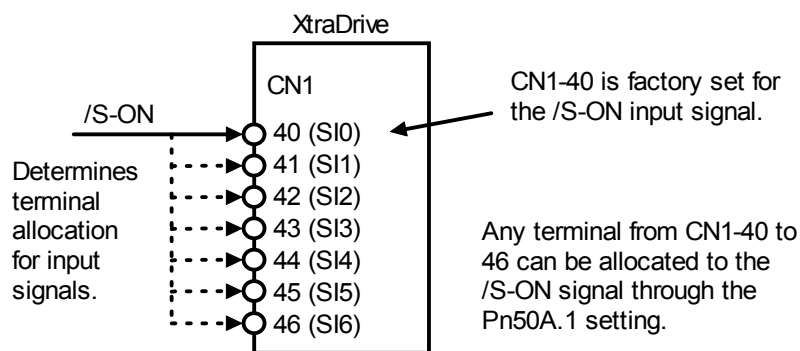

The following table shows the parameter default settings for input settings 1 to 4.

Parameter	Signal	Setting	Description
Pn50A	Input Signal Selection 1	Default Setting: 2100	Speed/Torque Control, Position Control
Pn50B	Input Signal Selection 2	Default Setting: 6543	Speed/Torque Control, Position Control
Pn50C	Input Signal Selection 3	Default Setting: 8888	Speed/Torque Control, Position Control
Pn50D	Input Signal Selection 4	Default Setting: 8888	Speed/Torque Control, Position Control

Select the input terminal on the CN1 connector that will be used for all input signals.

■ Examples of Input Signal Allocation

The procedure used to allocate sequence input signals is described using the /S-ON signal as a typical example.

Pn50A.1 Setting	Description	
0	Inputs the /S-ON signal from the SI0 (CN1-40) input terminal.	Signal polarity: Normal. Servo ON signal is valid when low (ON)
1	Inputs the /S-ON signal from the SI1 (CN1-41) input terminal.	
2	Inputs the /S-ON signal from the SI2 (CN1-42) input terminal.	
3	Inputs the /S-ON signal from the SI3 (CN1-43) input terminal.	
4	Inputs the /S-ON signal from the SI4 (CN1-44) input terminal.	
5	Inputs the /S-ON signal from the SI5 (CN1-45) input terminal.	
6	Inputs the /S-ON signal from the SI6 (CN1-46) input terminal.	
7	Sets /S-ON signal so that it is always valid.	Set the Servo-ON signal (/S-ON) so that it is always valid or always invalid.
8	Sets /S-ON signal so that it is always invalid.	
9	Inputs the S-ON signal from the SI0 (CN1-40) input terminal.	Signal polarity: Inversion. Valid at OFF (H level) with Servo ON signal
A	Inputs the /S-ON signal from the SI1 (CN1-41) input terminal.	
B	Inputs the S-ON signal from the SI2 (CN1-42) input terminal.	
C	Inputs the S-ON signal from the SI3 (CN1-43) input terminal.	
D	Inputs the S-ON signal from the SI4 (CN1-44) input terminal.	
E	Inputs the S-ON signal from the SI5 (CN1-45) input terminal.	
F	Inputs the /S-ON signal from the SI6 (CN1-46) input terminal.	

As shown in the table above, the /S-ON signal can be allocated to any input terminal from SI0 to SI6. /S-ON is always input when Pn50A.1 is set to 7, and an external signal line would therefore not be needed because the servo amplifier will determine whether the servo is ON or OFF.

The /S-ON signal is not used when Pn50A.1 is set to 8. This setting is meaningful only in the following instances.

- When the factory set input signal is to be replaced by another input signal.
- The signal must be left ON (low level) during normal operation to make the signal valid when OFF (high level) when forward run prohibit (P-OT) and reverse run prohibit (N-OT) are input. The input terminal signal line must be left ON even in system configurations that do not require this signal, but unnecessary wiring can be eliminated by setting Pn50A.1 to 8.
- By setting 9 to F, the signal polarity can be reversed.

Note: Several signals can be allocated to the same input circuit.

When the servo is ON, the forward run prohibit or reverse run prohibit signal is used.

At a setting with inverted polarity, the failed safe operation may not be possible in the case of signal line disconnection.

■ Allocating Other Input Signals

Input signal allocation can be changed as shown below.

Input Signal		Parameter		Description
Name	Applicable Logic	Number	Setting	
Proportional Control Reference (/P-CON)	ON (low level)	Pn50A.2	0	Inputs the specified signal from SI0 (CN1-40).
			1	Inputs the specified signal from SI1 (CN1-41).
			2	Inputs the specified signal from SI2 (CN1-42).
			3	Inputs the specified signal from SI3 (CN1-43).
			4	Inputs the specified signal from SI4 (CN1-44).
			5	Inputs the specified signal from SI5 (CN1-45).
			6	Inputs the specified signal from SI6 (CN1-46).
			7	Sets the specified signal to always enabled.
			8	Sets the specified signal to always disabled.
			9	Inputs the specified inverse signal from SI0 (CN1-40).
			A	Inputs the specified inverse signal from SI1 (CN1-41).
			B	Inputs the specified inverse signal from SI2 (CN1-42).
			C	Inputs the specified inverse signal from SI3 (CN1-43).
			D	Inputs the specified inverse signal from SI4 (CN1-44).
E	Inputs the specified inverse signal from SI5 (CN1-45).			
F	Inputs the specified inverse signal from SI6 (CN1-46).			
Forward Run Prohibit (P-OT)	OFF (high level)	Pn50A.3	0 to F	Same as above.*
Reverse Run Prohibit (N-OT)		Pn50B.0		
Alarm Reset (/ARM-RST)	ON (low level)	Pn50B.1		
Forward Current Limit (/P-CL)		Pn50B.2		
Reverse Current Limit (/N-CL)		Pn50B.3		
Contact Input Speed Control Selection (/SPD-D)	—	Pn50C.0		
Contact Input Speed Control Selection (/SPD-A)		Pn50C.1		
Contact Input Speed Control Selection (/SPD-B)		Pn50C.2		
Control Mode Selection (/C-SEL)	ON (low level)	Pn50C.3		
Zero Clamp (/ZCLAMP)		Pn50D.0		
Reference Pulse Inhibit (/INHIBIT)		Pn50D.1		
Gain Switching (/G-SEL)		Pn50D.2		

Note: *Same as above” means that input signals and terminals SI0 to SI6 are enabled or disabled through parameter settings 0 to 8.

5.3.4. Output Circuit Signal Allocation

■ Output Signal Allocation

Output signal functions can be allocated to the sequence signal output circuits shown below.

CN1 Connector Terminal Numbers	Output Terminal Name	Default Setting		Comments
		Symbol	Name	
25	SO1	/V-CMP+ (/COIN+)	Speed coincidence detection (positioning completed)	The signal output will vary depending on the control mode.
26 (SG)		/V-CMP- (/COIN-)		
27	SO2	/TGON+	Rotation detection	—
28 (SG)		/TGON-		
29	SO3	/S-RDY+	Servo ready	—
30 (SG)		/S-RDY-		

■ Output Signal Selection Default Settings

The output signal selection parameters and their default settings are shown below.

Parameter	Signal	Setting	Description
Pn50E	Output Signal Selections 1	Default Setting: 3211	Speed/Torque Control, Position Control
Pn50F	Output Signal Selections 2	Default Setting: 0000	Speed/Torque Control, Position Control
Pn510	Output Signal Selections 3	Default Setting: 0000	Speed/Torque Control, Position Control

Select the CN1 connector terminals that will output the signals.

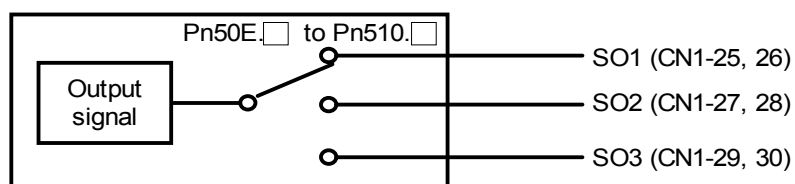

■ Allocating Other Output Signals

Output Signal	Parameter		Description
	Number	Setting	
Positioning Completed (/COIN)	Pn50E.0	0	Disabled. (Not used for the specified output signal.)
		1	Outputs the specified signal from the SO1 (CN1-25 and 26) output terminal.
		2	Outputs the specified signal from the SO2 (CN1-27 and 28) output terminal.
		3	Outputs the specified signal from the SO3 (CN1-29 and 30) output terminal.
Speed Coincidence Detection(/V -CMP)	Pn50E.1	0 to 3	Same as above. (Output signals are disabled or allocated to output terminals SO1 to SO3 through parameter settings 0 to 3).
Rotation Detection (/TGON)	Pn50E.2	0 to 3	
Servo Ready (/S-RDY)	Pn50E.3	0 to 3	
Torque Limit Detection (/CLT)	Pn50F.0	0 to 3	
Speed Limit Detection (/VLT)	Pn50F.1	0 to 3	
Brake Interlock (/BK)	Pn50F.2	0 to 3	
Warning(/WARN)	Pn50F.3	0 to 3	
Near(/NEAR)	Pn510.0	0 to 3	
Not used	—	—	

Note: Signals are output with OR logic when multiple signals are allocated to the same output circuit. Signals that are not detected are invalid. For example, the positioning completed signal /COIN is invalid in Speed Control mode.

The following parameters can be used to invert the signals on output terminals SO1 to SO3.

Parameter	Signal	Setting	Description
Pn512	Output Signal Inverted Setting	Default Setting: 0000	Speed/Torque Control, Position Control

These settings specify which of the connector CN1 output signals are to be inverted:

Output Terminal	Parameter		Description
	Number	Setting	
SO1 (CN1 -25, 26)	Pn512.0	0	Does not invert the signal.
		1	Inverts the signal.
SO2(CN1 -27, 28)	Pn512.1	0	Does not invert the signal.
		1	Inverts the signal.
SO3(CN1-29, 30)	Pn512.2	0	Does not invert the signal.
		1	Inverts the signal.
Not used.	Pn512.3	—	—

5.3.5. Control Mode Selection

The XtraDrive servo amplifier offers speed control, position control, torque control, and the other control modes shown in the following table.

The following parameter is used to set the control mode.

Parameter	Signal	Setting	Control Mode
Pn000.1	Control Method Selection	Default Setting: 0	Speed/Torque Control, Position Control

Pn000.1 Setting	Control Mode
0	Speed Control (Analog Reference)
2	Torque Control (Analog Reference)
3	Contact Input Speed Control Selection (Contact Reference)
4	Contact Input Speed Control Selection (Contact Reference) ↔ Speed Control (Analog Reference)
5	Not Used
6	Not Used
7	Not Used
8	Not Used
9	Torque Control (Analog Reference) ↔ Speed Control (Analog Reference)
A	Speed Control (Analog Reference) ↔ Zero Clamp Control
B	Position Control (Pulse Train Reference) ↔ Position Control (Inhibit)
C	Position Control (Pulse Train Reference)
D	Programming Mode (Serial Communication Command)

■ Description of Control Modes

The control modes are described below.

(0) Speed Control (Analog Reference)

This mode controls speed using an analog voltage input reference. See *5.2.1 Speed Reference*.

(2) Torque Control (Analog Reference)

This mode controls torque using an analog voltage input reference. See *5.2.7 Using Torque Control*.

(3) Contact Input Speed Control Selection (Contact Reference)

This mode uses the /P-CON (/SPD-D), /P-CL (/SPD-A), and /N-CL (/SPD-B) input signals to control speed as it switches among the three preset operating speeds in the servo amplifier. See 5.2.6 *Contact Input Speed Control*.

(4) Contact Input Speed Control Selection (Contact Reference) ↔ Speed Control (Analog Reference)

This mode controls speed by switching between contact reference and analog voltage reference speed control. Analog voltage reference speed control is enabled when both /P-CL (/SPD-A) and /N-CL (/SPD-B) input signals are OFF (high level). See 5.2.6 *Contact Input Speed Control*.

(9) Torque Control (Analog Reference) ↔ Speed Control (Analog Reference)

This mode switches between torque and speed control through the /P-CON (/C-SEL) signal. See 5.2.7 *Using Torque Control*.

(A) Speed Control (Analog Reference) ↔ Zero Clamp

This speed control mode is used to set the zero clamp function when the servo amplifier is stopped. Zero clamp operates when the /P-CON (/ZCLAMP) signal is ON (low level). See 5.4.3 *Using the Zero Clamp Function*.

(B) Position Control (Pulse Train Reference) ↔ Position Control (Inhibit)

This mode controls positioning by inhibiting reference pulse input through the /P-CON (/INHIBIT) signal. See 5.2.10 *Reference Pulse Inhibit Function (INHIBIT)*

(C) Position Control (Pulse Train Reference)

This mode controls positioning using a pulse train input reference. See 5.2.2 *Position Reference*.

(D) Programming Mode (Serial Communication Command)

This mode controls positioning and torque using a serial communication. See 5.9 *Configuration of Serial Command for AB Encoders*.

5.4. Setting Stop Functions

This section describes the procedure used to stop the servo amplifier properly.

5.4.1. Adjusting Offset

■ When the Servomotor Will Not Stop

The servomotor may rotate at very low speed and not stop even when 0V is specified as the reference voltage for servo amplifier speed and torque control (analog reference). This happens when the reference voltage from the host controller or external circuit is slightly offset (in mV units). The servomotor will stop if this offset is properly adjusted to 0V.

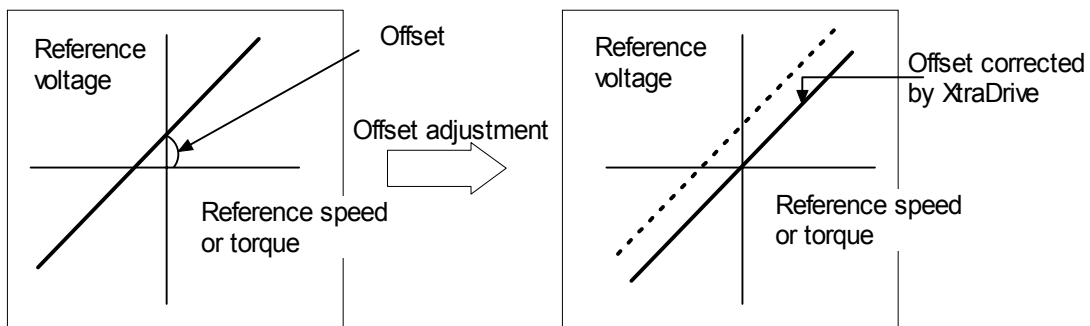

■ Reference Offset Adjustment

The following methods can be used to adjust the reference offset to 0V.

Adjustment Method	Result
Automatic Adjustment of Reference Offset	The reference offset is automatically adjusted to 0V.
Manual Adjustment of Reference Offset	The reference offset can be set to a specified value.

Note: Use manual rather than automatic adjustment if a position control loop is formed in the host controller.

See the following sections in *Chapter 7 Using the Panel Operator* for more details on adjustment procedures:

Adjustment Method	Reference Source
Automatic Adjustment of Reference Offset	7.2.3 Automatic Adjustment of the Speed and Torque Reference Offset
Manual Adjustment of Reference Offset	7.2.4 Manual Adjustment of the Speed and Torque Reference Offset

5.4.2. Servo OFF Stop Mode Selection

To stop the servomotor by applying the dynamic brake (DB), set the desired mode in the following parameter. The servomotor will stop due to equipment friction if the dynamic brake is not applied.

Parameter	Signal	Setting (ms)	Description
Pn001.0	Servo OFF or Alarm Stop Mode	Default Setting: 0	Speed/Torque Control, Position Control

The XtraDrive servo amplifier turns OFF under the following conditions:

- The Servo ON input signal (/S-ON, CN1-40) is turned OFF.
- A servo alarm occurs.
- Power is turned OFF.

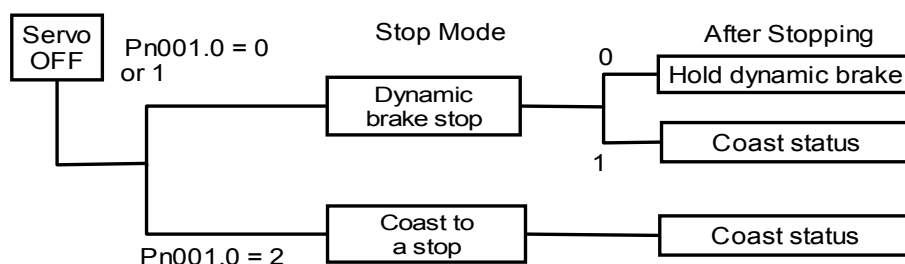

Specify the Stop mode as one of these options.

Pn001.0 Setting	Result
0	Uses the dynamic brake to stop the servomotor. Maintains dynamic brake after the servomotor stops.*
1	Uses the dynamic brake to stop the servomotor. Releases dynamic brake after the servomotor stops, and the servomotor coasts to a stop.
2	Coasts the servomotor to a stop.** The servomotor is turned OFF and motion stops due to equipment friction.

Note: * If the servomotor is stopped or moving at extremely low speed, it will coast to a stop.

** When the main power supply is turned OFF for the following servo amplifiers, the DB circuit is turned ON when the control power supply is OFF:

30 to 1500W for 200V

2.0 to 3.0kW for 400V

If the DB circuit needs to be turned OFF when the main power supply or the control power supply is OFF, disconnect the servo amplifier's wiring (U, V, and W).

Note: The dynamic brake is an emergency stop function. Do not repeatedly start and stop the servomotor using the servo ON signal (/S-ON) or by repeatedly turning power ON and OFF.

Note: The **dynamic brake (DB)** is a common way of quickly stopping a servomotor by electrically shorting its electrical windings. The DB circuit is incorporated into the servo amplifier.

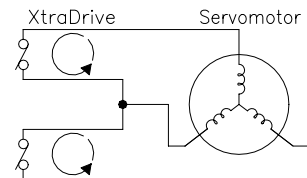

5.4.3. Using the Zero Clamp Function

■ Zero Clamp Function

The zero clamp function is used for systems where the host controller does not form a position loop for the speed reference input. In other words, this function is used to stop and lock the servomotor even when the input voltage of speed reference V-REF is not 0V. An internal position loop is temporarily formed to clamp the servomotor within one pulse when the zero clamp function is turned ON. Even if the servomotor is forcibly rotated by external force, it will still return to the zero clamp position.

A speed reference lower than the Pn501 setting is ignored

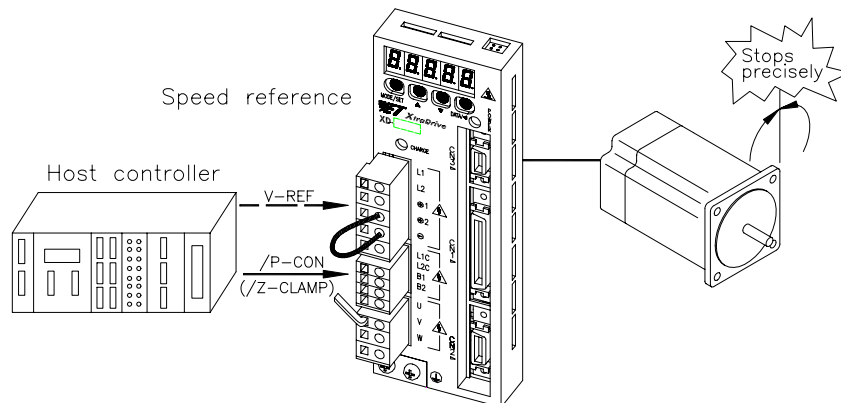

■ Parameter Setting

Set the following parameter so that the input signal /P-CON (/ZCLAMP) can be used to enable or disable the zero clamp function.

Parameter	Signal	Setting (ms)	Description
Pn000.1	Control Method Selection	Default Setting: 0	Speed Control

⇒ Input /P-CON CN1-41	Proportional Control, etc.	Speed/Torque Control, Position Control
-----------------------	----------------------------	--

Note: The /ZCLAMP signal can be used when an input circuit signal is allocated. See 5.3.3 *Input Circuit Signal Allocation* for more details.

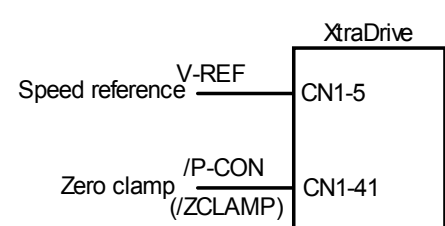
Pn000.1 Setting	Control Mode	
A	<p>Zero Clamp Control Mode This mode allows the zero clamp function to be set when the servomotor stops.</p> <ul style="list-style-type: none"> The speed reference is input from V-REF (CN1-5). /P-CON (/ZCLAMP)(CN1-41) is used to turn the zero clamp function ON and OFF. <p>CN1-41 is open (OFF). Turns the zero clamp function OFF.</p> <p>CN1-41 is 0V (ON). Turns the zero clamp function ON.</p>	 <p>Zero clamp is performed when the following two conditions are satisfied:</p> <ul style="list-style-type: none"> /P-CON (/ZCLAMP) is ON. Speed reference is below the setting designated at Pn501.

■ Setting Motor Speed

Use the following parameter to set the motor speed level at which zero clamp is performed

Parameter	Signal	Setting (rpm)	Description
Pn501	Zero Clamp Level	Setting Range: 0 to 10000 Default Setting: 10	Speed Control

If zero clamp speed control is selected, set the motor speed at which zero clamp is to be performed. The maximum speed will be used if the value of Pn501 is set higher than the maximum speed of the servomotor.

Zero Clamp Conditions

Zero clamp is performed when all the following conditions are satisfied:

- Zero clamp speed control is selected (parameter Pn000.1 is set to A).
- /P-CON (/ZCLAMP)(CN1-41) is ON (0V).
- Speed reference drops below the setting level of Pn501.

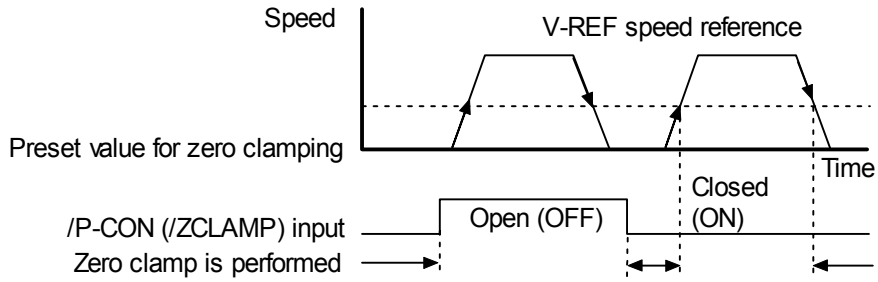

Note: When the /ZCLAMP signal is allocated, the zero clamp operation will be used even for speed control (Pn000.1 = 0).

5.4.4. Using the Holding Brake

The holding brake is used when a XtraDrive controls a vertical axis. In other words, a servomotor with brake prevents the movable part from shifting due to the force of gravity when system power goes OFF.

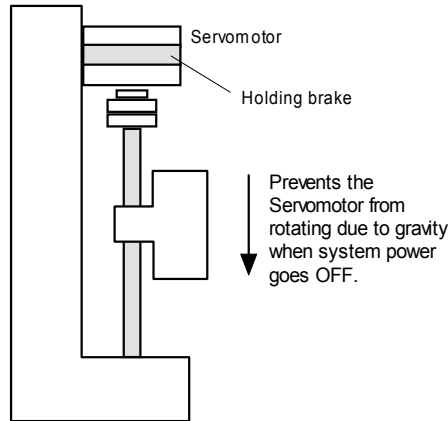

■ Wiring Example

Use the servo amplifier contact output signal /BK and the brake power supply to form a brake ON/OFF circuit. The following diagram shows a standard wiring example.

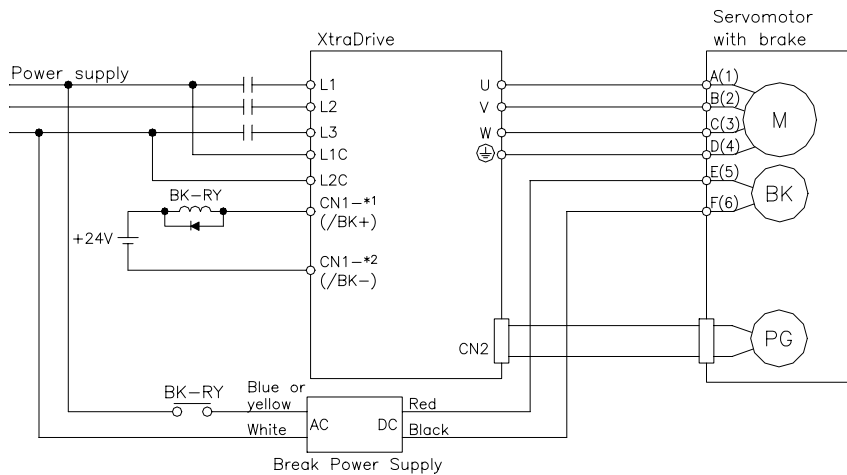

BK-RY: Brake control relay

Brake power supplies are available in 200-V and 100-V models.

*1 and *2 are the output terminals allocated with Pn510.0.

Output ⇒ /BK	Brake Interlock Output	Speed/Torque Control, Position Control
--------------	------------------------	--

This output signal controls the brake when using a servomotor with a brake and does not have to be connected when using a servomotor without a brake.

State	Status	Result
ON:	Closed or low level	Releases the brake.
OFF:	Open or high level	Applies the brake.

Related Parameters

Parameter	Description
Pn506	Time Delay from Brake Reference until Servo OFF
Pn507	Speed Level for Brake Reference Output during Motor Operation
Pn508	Timing for Brake Reference Output during Motor Operation

The following parameter must be selected to determine the location of the output signal, when the /BK signal is used.

Parameter	Signal	Setting	Description
Pn50F	Output Signal Selections 2	Default Setting: 0000	Speed/Torque Control, Position Control

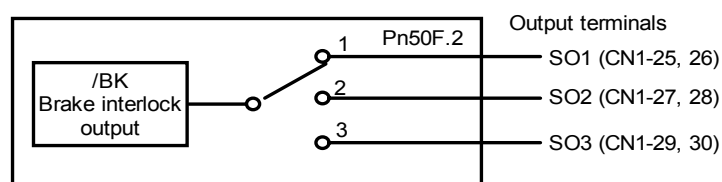

Select the /BK output terminal.

Parameter	Setting	Output Terminal (CN1)	
		1	2
Pn50F.2	0	—	—
	1	25	26
	2	27	28
	3	29	30

Note: Signals are output with OR logic when multiple signals are allocated to the same output circuit. Set other output signals to a value other than the one allocated to the /BK signal in order to output the /BK signal alone. See 5.3.4 *Output Circuit Signal Allocation*.

■ Brake ON Timing

If the equipment moves slightly due to gravity when the brake is applied, set the following parameter to adjust brake ON timing.

Parameter	Signal	Setting (10ms)	Description
Pn506	Brake Reference Servo OFF Delay Time	Setting Range: 0 to 50 Default Setting: 0	Speed/Torque Control, Position Control

This parameter is used to set the output time from the brake control signal /BK until the servo OFF operation (servomotor output stop) when a servomotor with a brake is used.

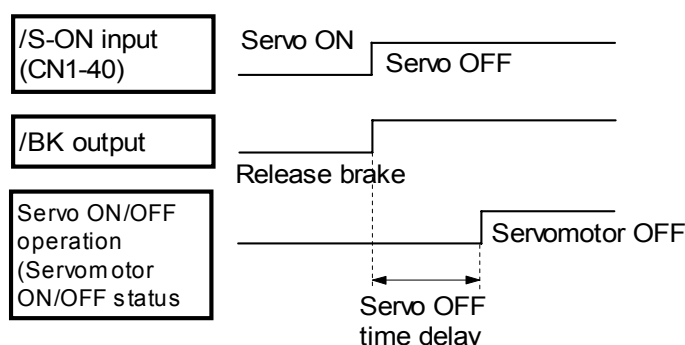

With the standard setting, the servo is turned OFF when the /BK signal (brake operation) is active. The equipment may move slightly due to gravity depending on equipment configuration and brake characteristics. If this happens, use this parameter to delay servo OFF timing.

This setting sets the brake ON timing when the servomotor is stopped. Use Pn507 and 508 for brake ON timing during operation.

Note: The servomotor will turn OFF immediately if an alarm occurs. The equipment may move due to gravity in the time it takes for the brake to operate.

■ Holding Brake Setting

Set the following parameters to adjust brake ON timing so the holding brake is applied when the servomotor stops.

Parameter	Signal	Setting	Description
Pn507	Brake Reference Output Speed Level	Setting Range: 0 to 10000rpm Default Setting: 100rpm	Speed/Torque Control, Position Control
Pn508	Timing for Brake Reference Output during Motor Operation	Setting Range: 0 to 100 x 10ms Default Setting: 50 x 10ms	Speed/Torque Control, Position Control

Set the brake timing to be used when the servo is turned OFF by input signal /S-ON (CN1-40) or when an alarm occurs during motor operation.

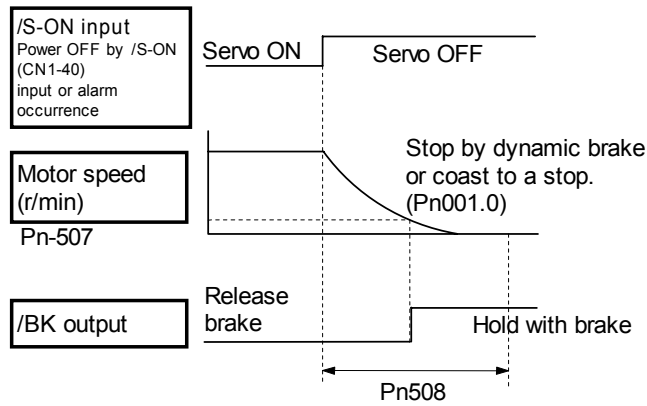

Servomotor OFF

Brake ON timing when the servomotor stops must be adjusted properly because servomotor brakes are designed as holding brakes. Adjust the parameter settings while observing equipment operation.

/BK Signal Output Conditions During Servomotor Operation

The circuit is open under either of the following conditions:

- Motor speed drops below the setting at Pn507 after servo OFF.
- The time set at Pn508 has elapsed since servo OFF.

The actual speed used will be the maximum speed even if Pn507 is set higher than the maximum speed.

5.5. Forming a Protective Sequence

This section describes the procedure for using I/O signals from the servo amplifier to form a protective safety sequence.

5.5.1. Using Servo Alarm and Alarm Code Outputs

The basic procedure for connecting alarm output signals is described below.

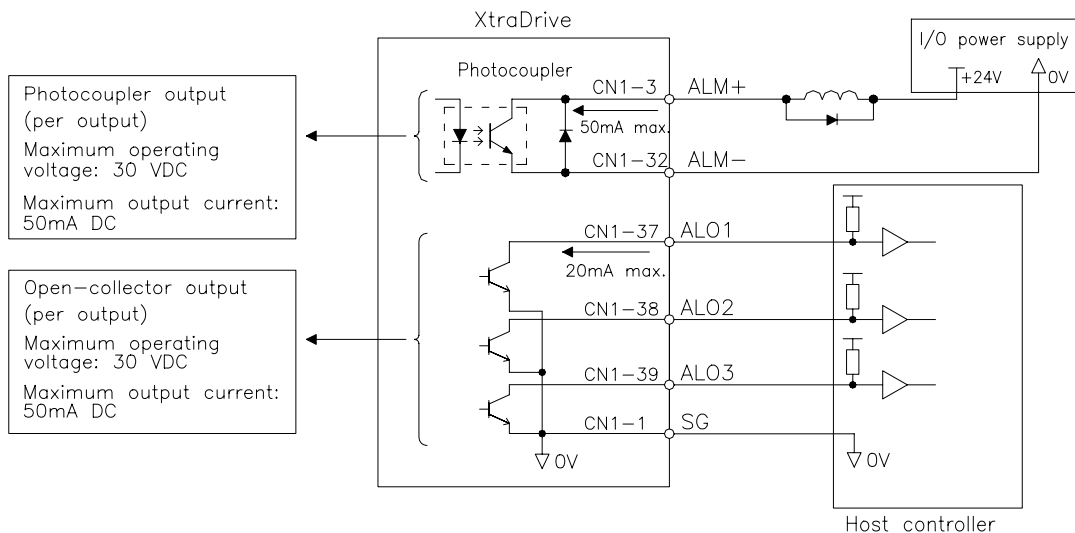

The user must provide a suitable external I/O power supply separately because there is no internal 24V power supply in the servo amplifier.

The use of the photocoupler output signals is described below.

Output ⇒ ALM+ CN1-31	Servo Alarm Output	Speed/Torque Control, Position Control
Output ⇒ ALM- CN1-32	Signal Ground for Servo Alarm Output	Speed/Torque Control, Position Control

These alarms are output when a servo amplifier alarm is detected.

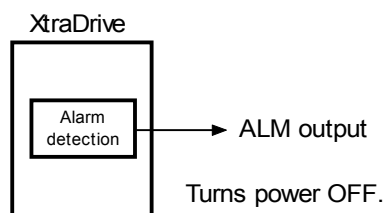

Form an external circuit so that this alarm output (ALM) turns OFF the servo amplifier.

State	Status	Result
ON	Circuit between CN1-31 and 32 is closed, and CN1-31 is at low level.	Normal state.
OFF	Circuit between CN1-31 and 32 is open, and CN1-31 is at high level.	Alarm state.

Alarm codes ALO1, ALO2 and ALO3 are output to indicate each alarm type.

The use of open-collector output signals ALO1, ALO2, and ALO3 is described below.

Output ⇒ ALO1 CN1-37	Alarm Code Output	Speed/Torque Control, Position Control
Output ⇒ ALO2 CN1-38	Alarm Code Output	Speed/Torque Control, Position Control
Output ⇒ ALO3 CN1-39	Alarm Code Output	Speed/Torque Control, Position Control
Output ⇒ /SG CN1-1	Signal Ground for Alarm Code Output	Speed/Torque Control, Position Control

These signals output alarm codes to indicate the type of alarm detected by the servo amplifier. Use these signals to display alarm codes at the host controller. See 9.2.3 *Alarm Display Table* for more on the relationship between alarm display and alarm code output.

When a servo alarm (ALM) occurs, eliminate the cause of the alarm and set the following /ALM-RST input signal to high level (ON) to reset the alarm.

Input ⇒ /ALM-RST CN1-44	Alarm Reset	Speed/Torque Control, Position Control
-------------------------	-------------	--

The Alarm Reset signal is used to reset a servo alarm.

Form an external circuit so that the servo amplifier turns OFF when an alarm occurs. Alarms are reset automatically when the control power supply is turned OFF.

Alarms can also be reset using a panel or digital operator.

- Note:**
1. Encoder alarms cannot always be reset by inputting the /ALM-RST signal. In that case, turn the control power supply OFF to reset the alarm.
 2. When an alarm occurs, always eliminate the cause before resetting the alarm. See 9.2.1 *Troubleshooting Problems with Alarm Displays* for more details on troubleshooting the system when an alarm occurs.
 3. In a Position Control Alarm Code do not relate to trajectory errors.

5.5.2. Using the Servo ON Input Signal (/S-ON)

This section describes the basic use and wiring procedure for the Servo ON (/S-ON) input signal (sequence input signal). Use this signal to forcibly turn OFF the servomotor from the host controller.

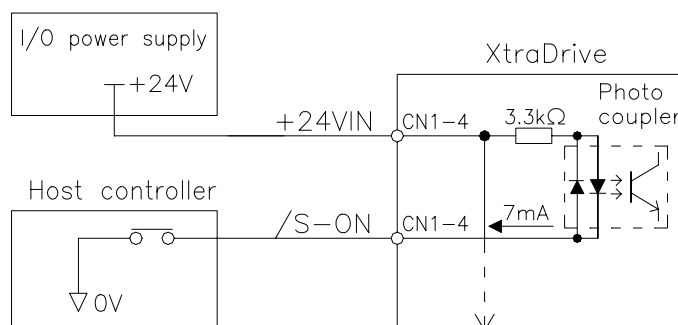

⇒ Input /S-ON CN1-40	Servo ON	Speed/Torque Control, Position Control
----------------------	----------	--

This signal is used to turn the servomotor ON and OFF.

CN1-40 State	Status	Result
ON	Closed or low level	Turns ON the servomotor: operates according to signal input. This is the default state.
OFF	Open or high level	Servomotor cannot operate. Do not turn OFF the servomotor while it is operating except in an emergency.

⚠ CAUTION

- **Do not use the Servo ON (/S-ON) signal to start or stop the motor. Always use an input reference signal, such as Speed Reference to start or stop the servomotor.** Using the Servo ON signal to start or stop the motor will shorten the life of the servo amplifier.

Set the following parameter to 7 if the /S-ON signal will not be used.

Parameter	Signal	Setting	Description
Pn50A.1	/S-ON Signal Mapping	Default Setting: 0	Speed/Torque Control, Position Control

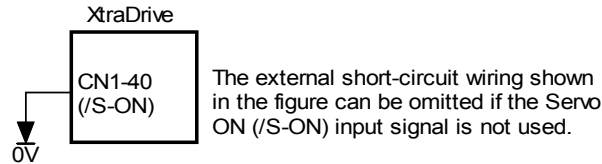

Pn50A.1 Setting	Status	Result
0	Enables the servo ON (/S-ON) input signal.	The servo is OFF when CN-40 is open and ON when CN1-40 is at 0V.
7	Disables the servo ON (/S-ON) input signal.	The servo is always ON and has the same effect as shorting CN1-40 to 0V.

Note: See 5.3.3 Input Circuit Signal Allocation for other Pn50A.1 settings.

5.5.3. Using the Positioning Completed Output Signal (/COIN)

This section describes the basic use and wiring procedures for the positioning completed (/COIN) output signal (photocoupler output signal). The signal is output to indicate that servomotor operation is completed.

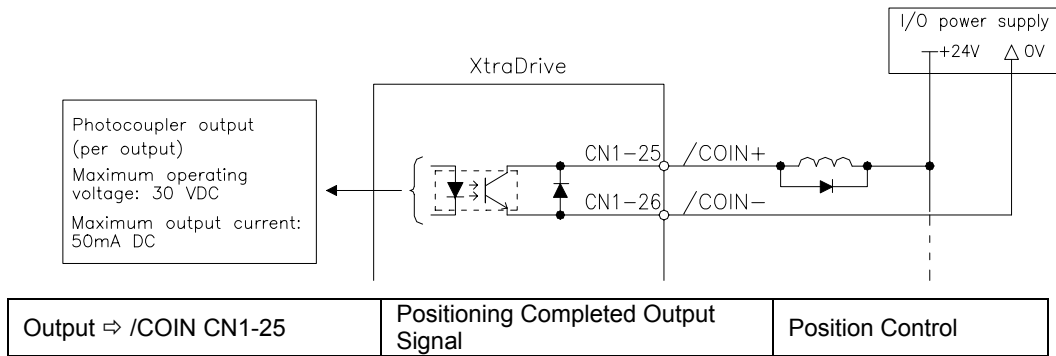

This signal indicates that the servomotor movement during position control has been completed. The host controller uses the signal as an interlock to confirm that positioning is completed.

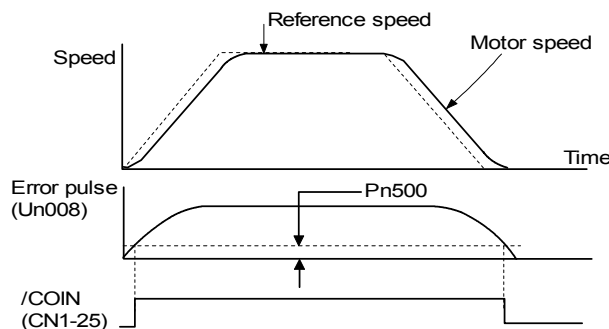

/COIN State	Status	Result
ON	Circuit between CN1-25 and 26 is closed, and CN1-25 is at low level.	Positioning is completed. (Position error is below the setting.)

OFF	Circuit between CN1-25 and 26 is open, and CN1-25 is at high level.	Positioning is not completed. (Position error is above the setting.)
-----	---	---

The following parameter is used to change the CN1 connector terminal that outputs the /COIN signal.

Parameter	Signal	Setting (rpm)	Description
Pn50E	Output Signal Selection 1	Default Setting: 3211	Position Control

The parameter is factory set so the /COIN signal is output between CN1-25 and 26. See 5.3.4 *Output Circuit Signal Allocation* for more details on parameter Pn50E.

The following parameter is used to set the number of error pulses and to adjust the output timing of the positioning completed signal.

Parameter	Signal	Setting (reference units*)	Description
Pn500	Positioning Completed Width	Setting Range: 0 to 250 Default Setting: 7	Position Control

Note: *Reference units for this parameter are the number of input pulses as defined using the electronic gear function; if a Serial Command is used, it is defined in Position Units.

This parameter is used to set output timing for the positioning completed signal (/COIN) when the position reference pulse is input and servomotor operation is completed.

Set the number of error pulses in reference units.

Too large a value set at this parameter may output only a small error during low-speed operation that will cause the /COIN signal to be output continuously.

The positioning completed width setting has no effect on final positioning accuracy.

Note: /COIN is a position control signal.

With the default setting, this signal is used for the speed coincidence output /V-CMP for speed control, and it is always ON for torque control.

5.5.4. Speed Coincidence Output (/V-CMP)

This section describes the basic use and wiring procedures for the speed coincidence (/V-CMP) output signal (photocoupler output signal), used to indicate a match with the speed reference. The host controller uses the signal as an interlock.

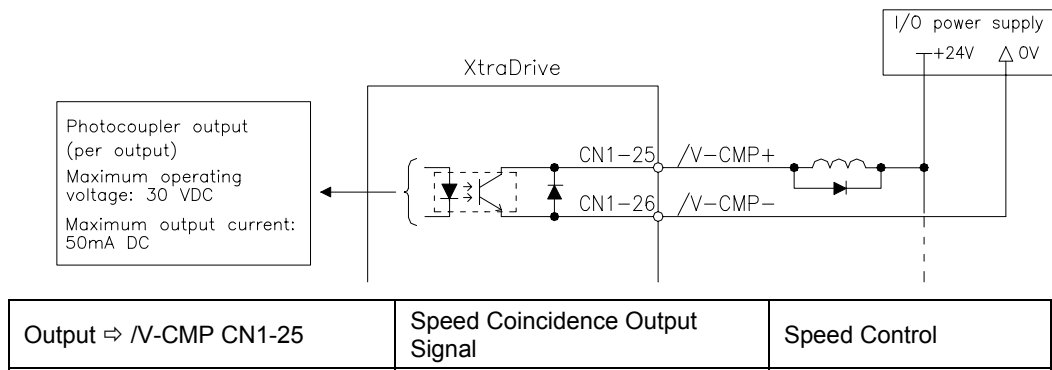

This signal is output when the actual motor speed during speed control is the same as the speed reference input.

/V-CMP State	Status	Result
ON	Circuit between CN1-25 and 26 is closed, and CN1-25 is at low level.	Speed coincides. (Speed error is below the setting.)
OFF	Circuit between CN1-25 and 26 is open, and CN1-25 is at high level.	Speed does not coincide. (Speed error is above the setting.)

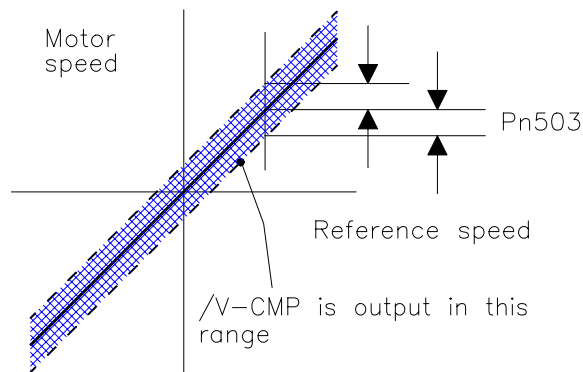

The following parameter setting is used to change the CN1 connector terminal that outputs the /V-CMP signal.

Parameter	Signal	Setting (rpm)	Description
Pn50E	Output Signal Selections 1	Default Setting: 3211	Position Control

The parameter is default set so the /V-CMP signal is output between CN1-25 and 26. See 5.3.4 *Output Circuit Signal Allocation* for more details on parameter Pn50E.

The following parameter is used to set conditions for speed coincidence output.

Parameter	Signal	Setting (rpm)	Description
Pn503	Speed Coincidence Signal Output Width	Setting Range: 0 to 100 Default Setting: 10	Speed Control

This parameter is used to set conditions for speed coincidence signal /TGON output.

The /V-CMP signal is output when the difference between the speed reference and actual motor speed is below this setting.

Example: The /V-CMP signal turns ON at 1900 to 2100rpm if the parameter is set to 100 and the reference speed is 2000rpm.

Note: /V-CMP is a speed control signal. With the default setting, this signal is used as the positioning completed signal /COIN for position control, and it is always ON for torque control.

5.5.5. Using the Running Output Signal (/TGON)

This section describes the basic use and wiring procedures for the running (/TGON) output signal (photocoupler output signal). The signal can be activated to indicate that the servomotor is currently operating. It is used as an external interlock.

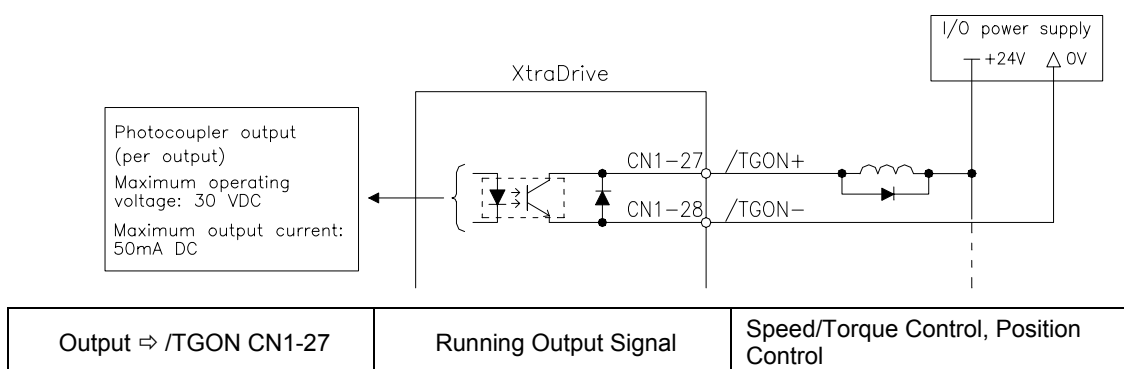

/TGON State	Status	Result
ON	Closed or low level.	Servomotor is operating. (Motor speed is above the setting level).
OFF	Open or high level.	Servomotor is not operating. (Motor speed is below the setting level).

The following parameter setting is used to change the CN1 connector terminal that outputs the /TGON signal.

Parameter	Signal	Setting (rpm)	Description
Pn50E	Output Signal Selections 1	Default Setting: 3211	Position Control

The parameter is default set so the /TGON signal is output between CN1-27 and 28. See 5.3.4 *Output Circuit Signal Allocation* for more details on parameter Pn50E.

This parameter is used to set output conditions for the operation detection output signal /TGON.

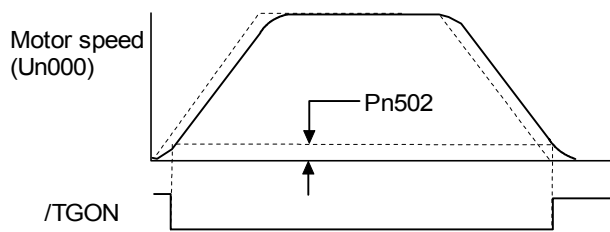

Parameter	Signal	Setting (rpm)	Description
Pn502	Rotation Detection Level	Setting Range: 1 to 10000 Default Setting: 20	Speed/Torque Control, Position Control

This parameter is used to set the speed at which the servo amplifier determines that the servomotor is running and then to output an appropriate signal. The following signals are generated when motor speed exceeds the preset level.

Signals generated when servomotor operation is detected:

- /TGON
- Status Indication Mode
- Monitor Mode Un006

5.5.6. Using the Servo Ready Output Signal (/S-RDY)

This section describes the basic use and wiring procedures for the Servo Ready (/S-RDY) output signal (photocoupler output signal).

Servo Ready means there are no servo alarms and the main circuit power supply is turned ON. An added condition with absolute encoder specifications is that the SEN signal is at high level and absolute data was output to the host controller.

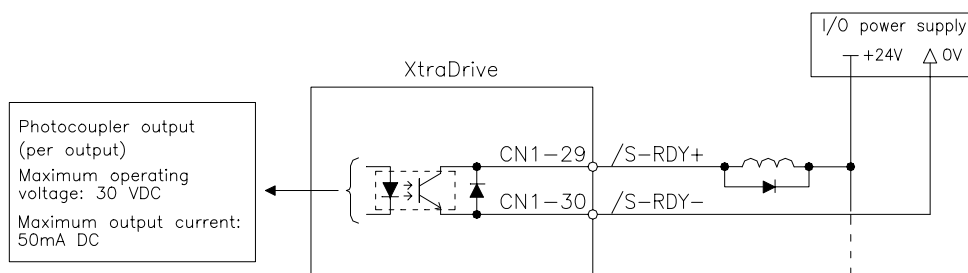

Output ⇒ / S-RDY CN1-29	Servo Ready Output Signal	Speed/Torque Control, Position Control
-------------------------	---------------------------	--

This signal indicates that the servo amplifier has completed all preparations and is ready to receive the Servo ON signal.

/S-RDY State	Status	Result
ON	Closed or low level.	Servomotor is ready
OFF	Open or high level.	Servomotor is not ready

The following parameter setting is used to change the CN1 connector terminal that outputs the /S-RDY signal.

Parameter	Signal	Setting	Description
Pn50E	Output Signal Selections 1	Default Setting: 3211	Position Control

The parameter is factory set so the /V-CMP signal is output between CN1-29 and 30. See 5.3.4 *Output Circuit Signal Allocation* for more details on parameter Pn50E.

5.5.7. Using the Warning Output Signal (/WARN)

This section describes the basic use and wiring procedure for the warning (/WARN) output signal (photocoupler output signal).

The signal consists of the following two output signals.

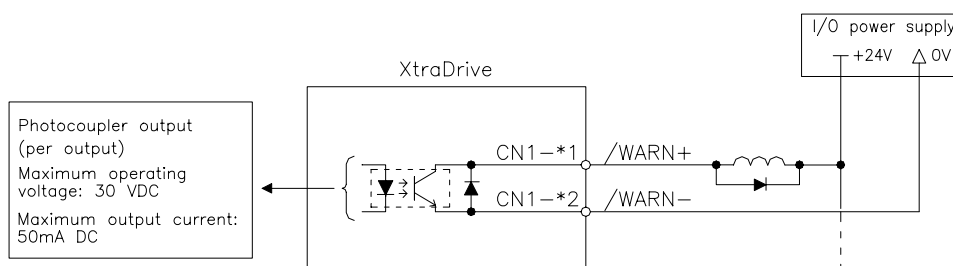

NOTE User constant Pn503F.3 is used to allocate output terminals for *1 and *2.

Output ⇨ /WARN	Warning Output Signal	Speed/Torque Control, Position Control
----------------	-----------------------	--

This output signal indicates an overload or regenerative overload warning.

/WARN State	Status	Result
ON	Closed or low level.	Error warning.
OFF	Open or high level.	Normal operation. No warning.

The following parameter setting is used to change the CN1 connector terminal that outputs the /WARN signal.

Parameter	Signal	Setting	Control Mode
Pn50F	Output Signal Selections 2	Default Setting: 0000	Speed/Torque Control, Position Control

Pn50F.3 is used to allocate the /WARN output signals above.

Pn50F.3 State	Output Terminal (CN1-)	
	*1	*2
0	—	—
1	25	26
2	27	28
3	29	30

Note: *1 and *2 are output terminals allocated with parameter Pn 510.0.
 Multiple signals allocated to the same output terminal follow Boolean OR logic. In order to use the /WARN output signal alone, set other output signals to a value other than the one allocated to the /WARN signal. See 5.3.4 *Output Circuit Signal Allocation*.

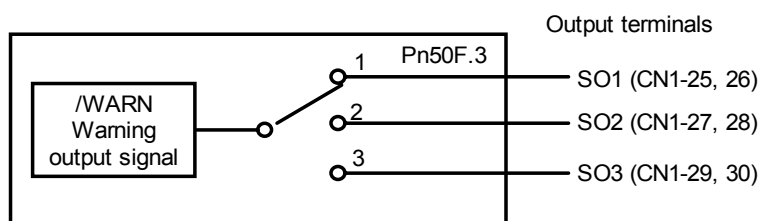

The following parameter is used to output warning details with an alarm code.

Parameter	Signal	Setting	Control Mode
Pn001.3	Warning Code Output Selection	Default Setting: 0	Speed/Torque Control, Position Control

Pn001.3 Setting	Result
0	Outputs alarm codes only for alarm codes ALO1, ALO2 and ALO3.
1	Outputs both alarm and warning codes for alarm codes ALO1, ALO2 and ALO3 and outputs an alarm code when an alarm occurs.

The following warning codes are output in 3 bits.

Warning Indication	Warning Code Output			Warning Description
	ALO1	ALO2	ALO3	
A.91	ON signal (low level)	OFF signal (high level)	OFF signal (high level)	Overload
A.92	OFF signal (high level)	ON signal (low level)	OFF signal (high level)	Regenerative overload

To use the /NEAR signal, an output terminal must be allocated with the parameter below.

Parameter	Signal	Setting	Control Mode
Pn510	Output Signal Selections 3	Default Setting: 0000	Position Control

5.5.8. Handling Power Loss

The following parameter is used to specify whether to generate an alarm when power loss occurs.

Parameter	Signal	Setting (ms)	Description
Pn509	Momentary Hold Time	Setting Range: 20 to 1000 Default Setting: 20	Speed/Torque Control, Position Control

The servo amplifier turns the servomotor OFF if it detects a voltage drop in the power supply. The default setting of 20ms means that servomotor operation will continue if power is lost for less than 20ms.

In the following instances, however, either a servo alarm is generated or control is lost (equivalent to normal power OFF operation) regardless of the parameter setting.

- When an insufficient voltage alarm (A.41) occurs during power loss with a large servomotor load.
- Loss of the control power supply is equivalent to normal power OFF operation, thus control is lost.

In power loss detection, the status of the main circuit power supply is detected and OFF status is ignored so that the servomotor's operation will continue if motor power turns back ON within the time set at user constant Pn509.

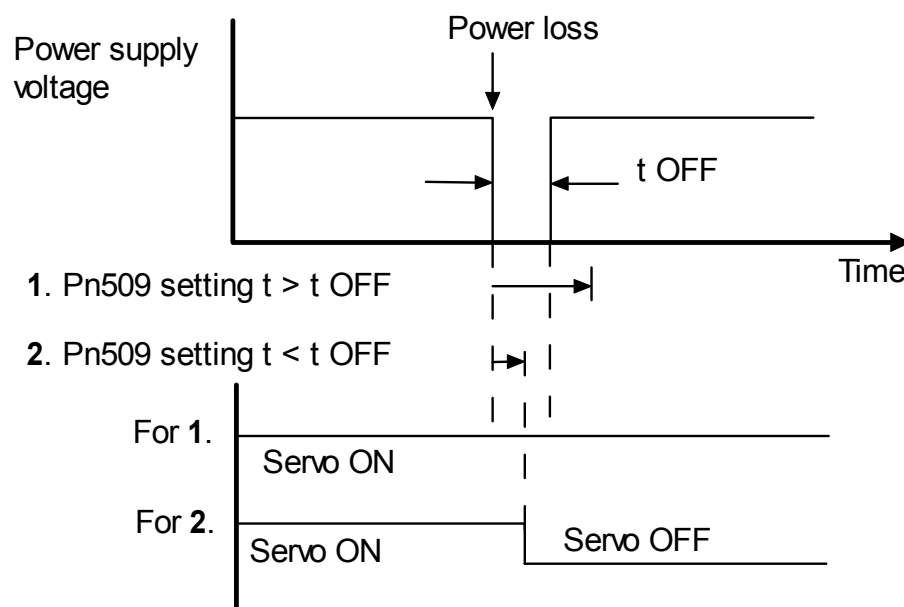

5.6. Selecting a Regenerative Resistor

When the servomotor operates in Generator mode, power is returned to the servo amplifier side. This is called regenerative power. The regenerative power is absorbed by charging the smoothing capacitor, but when the capacitor's charging limit is exceeded, the regenerative power is then reduced by the regenerative resistor.

The servomotor is driven in regeneration (generator) mode in the following conditions:

- While decelerating to a stop during acceleration/deceleration operation.
- With a load on the vertical axis.
- During continuous operation with the servomotor driven from the load side (negative load).

The capacity of the servo amplifier's built-in regenerative resistor is designed for short-term operation only, such as the deceleration stop period. Operation under a negative load is not possible.

If the regenerative power exceeds the processing capacity of the servo amplifier, install an external regenerative resistor. The following table shows the examples of specifications for servo amplifier's built-in resistor and the amount of regenerative power (average values) that it can process.

Applicable Servo Amplifiers		Built-in Resistor Specifications		Regenerative Power Processed by Built-in Resistor* (W)	Minimum Allowable Resistance (Ω)
		Resistance (Ω)	Capacity (W)		
Single-phase 200V	XD-P3-** to -04-**	—	—	—	40
	XD-08-**	50	60	12	
Three-phase 400V	XD-20DE to -30DE	45	140	28	44

Note: The amount of regenerative power (average value) that can be processed is rated at 20% of the capacity of the servo amplifier's built-in regenerative resistor.

When installing an external regenerative resistor, make sure that the resistance is the same as that of the servo amplifier's built-in resistor. If you combine multiple small-capacity regenerative resistors to increase the regenerative resistor capacity (W), select the resistors in a way that the resistance value including error is at least as high as the minimum allowable resistance shown in the table above.

5.6.1. External Regenerative Resistor

When installing an external regenerative resistor, a parameter setting must be changed as shown below.

Parameter	Signal	Setting (x 10W)	Description
Pn600	Regenerative Resistor Capacity	Setting Range: 0 to maximum Default Setting: 0	Speed/Torque Control, Position Control

The default setting of “0” in the above table is the set value when the servo amplifier’s built-in resistor is used or when a servo amplifier without a built-in resistor is used.

When installing an external regenerative resistor, set the regenerative resistor’s capacity (W).

Example: When the external regenerative resistor’s actual consumable capacity is 100W, set the parameter to “10” (10 x 10W = 100W)

Note: 1. In general, when resistors for power are used at the rated load ratio, the resistor temperature increases to between 200°C and 300°C. The resistors must be used at or below the rated values. Check with the manufacturer for the resistor’s load characteristics. Use resistors at no more than 20% of the rated load ratio with natural convection cooling, and no more than 50% of the rated load ratio with forced air-cooling. Parameter Pn600 must be set for the derated resistor.
2. Use of resistors with thermal switches is recommended as a safety precaution.

■ Connecting Regenerative Resistors

The method for connecting regenerative resistors is as follows.

Disconnect the wire between the servo amplifier’s B2 and B3 terminals and connect an external regenerative resistor between the B1 and B2 terminals.

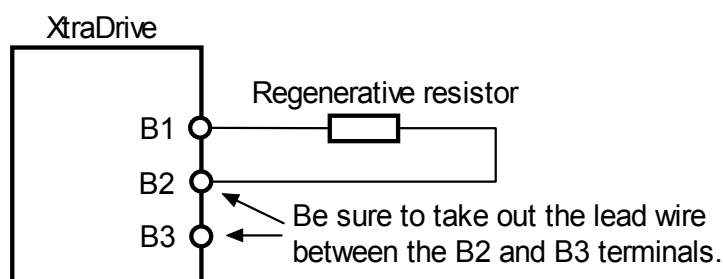

*The user must provide the regenerative resistor.

5.6.2. Calculating the Regenerative Power Capacity

■ Simple Calculation Method

When driving a servomotor normally along the horizontal axis, check the external regenerative resistor requirements using the calculation method shown below.

Servo Amplifiers with a Capacity of 400W or Less

Servo amplifiers with a capacity of 400W or less do not have built-in regenerative resistors. The energy that can be absorbed by capacitors is shown in the following table. If the rotational energy in the servo system exceeds these values, then connect a regenerative resistor externally.

Voltage	Applicable Servo Amplifiers	Regenerative Energy that Can Be Processed (Joules)	Comments
200V	XD-P3-**, -P5-**	18.5	Value when the input voltage is 200V AC
	XD-01-** to -04-**	37.1	

Calculate the rotational energy in the servo system using the following equation:

$$E_S = \frac{J \times (N_M)^2}{12566} \text{ Joules}$$

Where: $J = J_M + J_L$

J_M : Servomotor rotor inertia ($\text{kg}\cdot\text{m}^2$) ($\text{oz}\cdot\text{in}\cdot\text{s}^2$)

J_L : Motor axis conversion load inertia ($\text{kg}\cdot\text{m}^2$) ($\text{oz}\cdot\text{in}\cdot\text{s}^2$)

N_M : Rotation speed of the servomotor (rpm)

Servo Amplifier Capacity of 0.8 to 3.0kW

Servomotors with a capacity of 500W to 5kW have built-in regenerative resistors. The allowable frequencies for just the servomotor during acceleration/deceleration operation, in the run cycle from 0 \rightarrow maximum rotation speed \rightarrow 0, are summarized in the following table.

Convert the data into the values obtained with actual rotation speed used and load inertia to determine whether an external regenerative resistor is needed.

Voltage	Series	Allowable Frequencies in Regeneration Mode (r/min)								
	Capacity Symbol	03	05	08	09	10	13	15	20	30
200V	SGMAH	—	—	89	—	—	—	—	—	—
	SGMPH	—	—	29	—	—	—	17	—	—
	SGMGH-□A□A		34	—	13	—	10	—	12	8
	SGMSH	—	—	—	—	39	—	31	48	20
400V	SGMGH	—	42	—	15	—	10	—	12	8
	SGMSH	—	—	—	—	47	—	31	48	20
	SGMUH	—	—	—	—	27	—	19	—	13

Operating Conditions for Allowable Regenerative Frequency Calculation

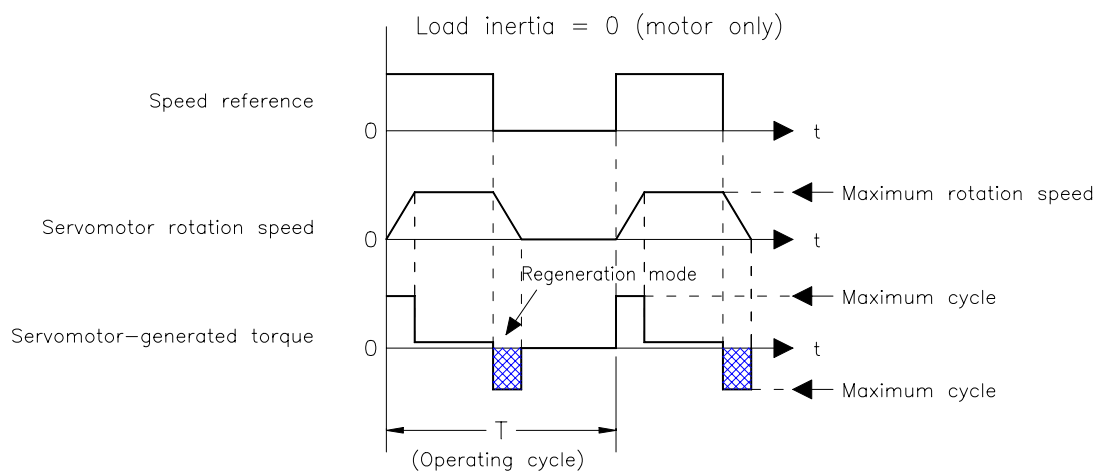

$$\text{Allowable frequency} = 1/T \text{ (r/min)}$$

Use the following equation to calculate the allowable frequency for regeneration mode operation.

$$\text{Allowable frequency} = \frac{\text{Allowable frequency for servomotor only}}{(1 + n)} \times \left(\frac{\text{Max. rotation speed}}{\text{Rotation speed used}} \right)^2 \frac{\text{Cycles}}{\text{Minute}}$$

Where: $n = J_L/J_M$

J_L : Motor axis conversion load inertia [oz·in·s² (kg·m²)]

J_M : Servomotor rotary inertia [oz·in·s² (kg·m²)]

■ Regenerative Energy Calculation Method

This section shows the procedure for calculating the regenerative resistor capacity when acceleration and deceleration operation is as shown in the following diagram.

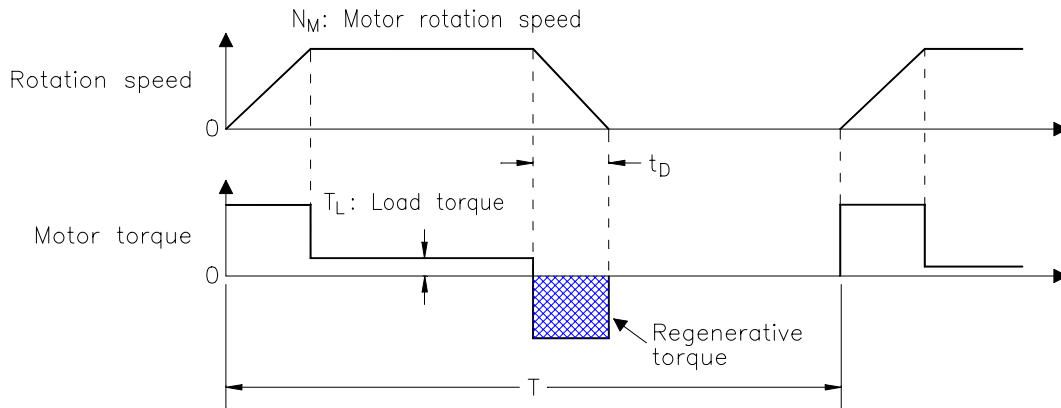

Calculation Procedure

The procedure for calculating the capacity is as follows:

Step	Procedure	Units [in. (mm)]	Equation
1	Find the rotational energy of the servo system (E_S).	$E_S =$ [Joules] = [J]= [oz·in·s ² (kg·m ² ·s ²)] $J_L =$ $J_M =$ J $N_M =$ rpm	$E_S = \frac{(J_L + J_M) \times N_M^2}{182}$ Where: N_M = Motor speed J_L = Load Inertia J_M = Motor Inertia
2	Find the energy consumed by load system loss (E_L) during the deceleration period (t_D).	$\tau_L =$ oz·in (N·m) $E_L =$ Joules = J $N_M =$ rpm $t_D =$ s	$E_L = \frac{\pi}{60} (N_M \times \tau_L \times t_D)$ Where: τ_L = Motor torque
3	Calculate the energy lost (E_M) from servomotor winding resistance.	$t_D =$ s = deceleration stopping time $E_M =$ Joules = J	$E_M =$ (Value from the “Servomotor Winding Resistance Loss” graph below) $\times t_D$
4	Calculate the servo amplifier energy (E_C) that can be absorbed.	$E_C =$ Joules = J	$E_C =$ Value from the “Absorbable Servo Amplifier Energy” graph below.
5	Find the energy consumed by the regenerative resistor (E_K).	$E_K = E_S = E_L = E_M = E_C =$ Joules = J	$E_K = E_S - (E_L + E_M + E_C)$
6	Calculate the required regenerative resistor capacity (W_K).	$W_K =$ W $E_K =$ Joules = J $T =$ s	$W_K = \frac{E_K}{0.2 \times T}$ Where: T = Time

Note: The “0.2” in the equation for calculating W_K is the value for when the regenerative resistor’s utilized load ratio is 20%.

If the previous calculation determines that the amount of regenerative power (W_{Wk}) that can be processed by the built-in resistor is not exceeded, then an external regenerative resistor is not required.

If the amount of regenerative power that can be processed by the built-in resistor is exceeded, install an external regenerative resistor for the capacity obtained from the above calculation.

If the energy consumed by load system loss (in step 2 above) is unknown, then perform the calculation using $E_L = 0$.

When the operation period in regeneration mode is continuous, add the following items to the calculation procedure above in order to find the required capacity (W) for the regenerative resistor.

- Energy for continuous regeneration mode operation period: E_G (joules)
- Energy consumed by regenerative resistor: $E_K = E_S - (E_L + E_M + E_C) + E_G$
- Required capacity of regenerative resistor: $W_K = E_K / (0.2 \cdot T)$
Here, $E_G = (2\pi/60) N_{MG} \times \tau_G \cdot t_G$
- τ_G : Servomotor's generated torque [oz·in (N·m)] in continuous regeneration mode operation period.
- N_{MG} : Servomotor rotation speed (rpm) for same operation period as above.
- t_G : Same operation period (s) as above.

Servo Amplifier's Absorbable Energy

The following diagrams show the relationship between the servo amplifier's input power supply voltage and its absorbable energy.

- XtraDrive for 200V motor

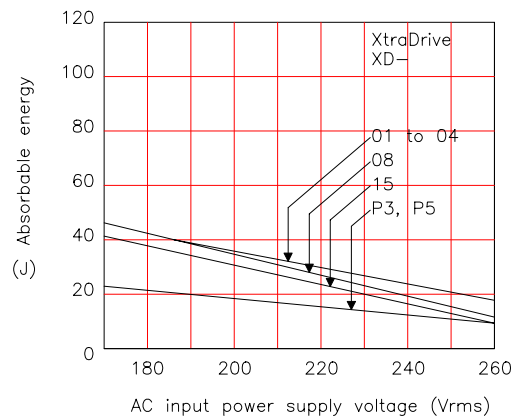

- XtraDrive for 400V motor

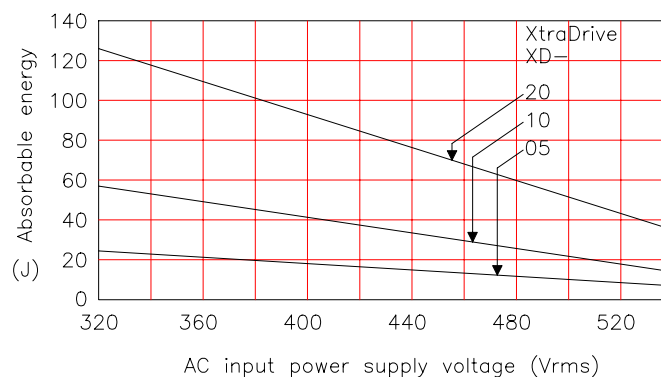

5.7. Absolute Encoders

If a motor with an absolute encoder is used, a system to detect the absolute position can be formed in the host controller. Consequently, automatic operation can be performed without zero return operation immediately after the power is turned ON.

Motor SGM□H-□□□1□…With 16-bit absolute encoder
 SGM□H-□□□2□…With 17-bit absolute encoder

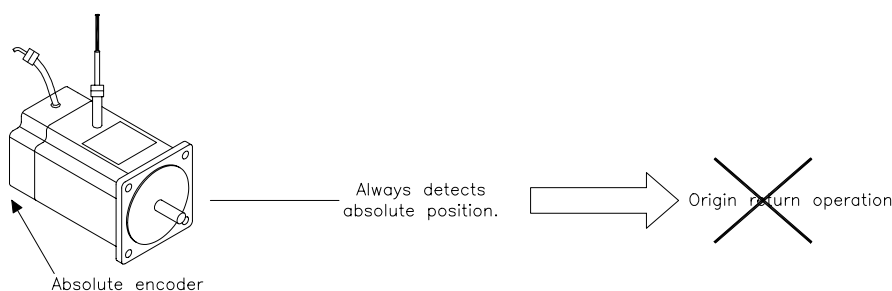

▲ WARNING

- When using the “Infinite Length Positioning System” be sure to take into account the changes made in the continuous counting method when limits are exceeded, as compared in the following table.
 The output range of multi-turn data for the XtraDrive series absolute detection system differs from the one used in conventional (Sigma) 12- and 15-bit encoder systems.

Absolute Encoder Type	Output Range of Multi-turn Data	When the Output Range Exceeds the Limit:
(Sigma) conventional type 12- and 15-bit encoder	-99999 to +99999	<ul style="list-style-type: none"> When the upper limit (+99999) is exceeded in positive direction, the counter displays 00000 and begins counting up again. When the lower limit (-99999) is exceeded in negative direction, the counter displays 00000 and begins counting down again.
XtraDrive Series 16- and 17-bit encoder	-32768 to +32767	<ul style="list-style-type: none"> When the upper limit (+32767) is exceeded in positive direction, the counter changes polarity (-32767) and begins counting up (toward zero and beyond). When the lower limit (-32767) is exceeded in negative direction, the counter changes polarity (+32767) and begins counting down (toward zero and beyond).

Note: After the limit has been changed in the multi-turn limit setting parameter (Pn205), the power must be cycled. This generates a Multi-turn Limit Disagreement Alarm (A.CC). Make sure that the entered value is appropriate before resetting this alarm. For more information see: 5.7.2 *Configuring an Absolute Encoder*, and 9.2.1 *Troubleshooting Problems with Alarm Displays*.

5.7.1. Interface Circuit

The following diagram shows the standard connections for an absolute encoder mounted to a servomotor.

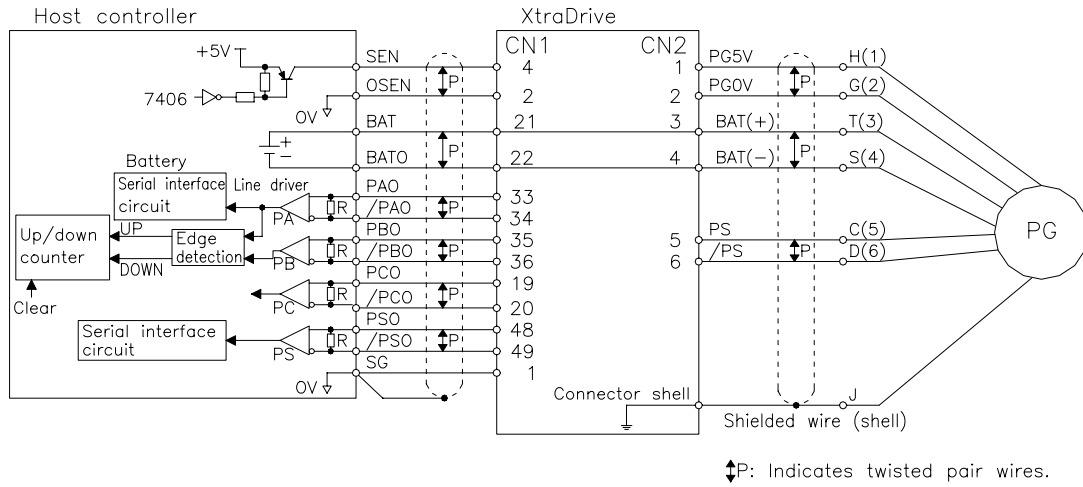

Applicable line receivers: SN75175 or MC3486 by TI.
 Terminating resistance R: 220 to 470Ω

■ SEN Signals

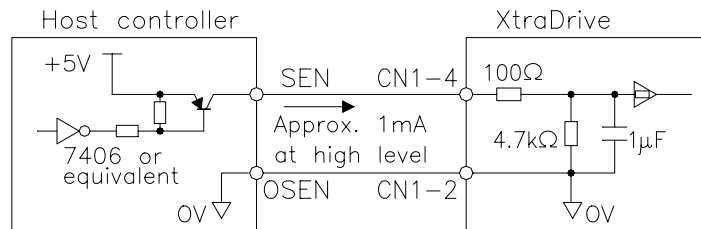

PNP is recommended for transistors.
 Signal Levels
 High level: 4.0V min.; Low level: 0.8V max.

- Wait at least three seconds after turning ON the power before raising the SEN signal to high level.
- When the SEN signal is changed from low level to high level, the multi-turn data and initial incremental pulses are transmitted.
- The motor cannot be operated until these operations are completed, regardless of the status of the servo ON signal (/S-ON).

Note: If for some reason it is necessary to turn OFF a SEN signal that is already ON, and then to turn it back ON again, maintain the high level for at least 1.3 seconds before turning it ON and OFF.

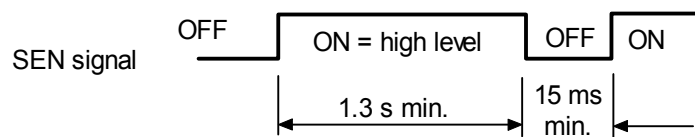

5.7.2. Configuring an Absolute Encoder

Select the absolute encoder's application with the following parameter.

Parameter	Signal	Setting	Control Mode
Pn002.2	Absolute Encoder Application	Setting Range: 0 or 1 Default Setting: 0	Speed/Torque Control, Position Control

Either "0" or "1" in the following table must be set in order to enable the absolute encoder.

Pn002.2 Setting	Result
0	Uses the absolute encoder as an absolute encoder.
1	Uses the absolute encoder as an incremental encoder.

The following parameter is used to periodically clear the encoder's counter (return the setting to 0) after a designated ratio of motor to load axis revolutions. This function is called the multi-turn limit.

Note: The term **Multi-turn Limit** refers to the highest number of rotations the encoder's counter will display before returning the counter to 0.

Parameter	Signal	Setting	Control Mode
Pn205	Multi-turn Limit Setting	Setting Range: 0 to 65535 Default Setting: 65535	Speed/Torque Control, Position Control

- When Pn205 is set to the default (65535), multi-turn data varies in the range of -32768 to $+32767$.
- With any other Pn205 value entered, data varies from 0 to the set value.

Note: To activate reassignment of this value, the user must first enter the change to the parameter, and then cycle (turn OFF and then turn ON) the power.

Since the encoder's multi-turn limit value is set by default to 65535, the following alarm occurs if the servo amplifier's power supply is cycled (turned OFF and ON) after changing parameter Pn205:

Alarm Display	Alarm Code Output			Description
	ALO1	ALO2	ALO3	
A.CC	O	X	O	Encoder multi-turn limit value does not match with that of the servo amplifier.

Note: O: ON ("L") signal
X: OFF ("H") signal

In order to set a multi-turn limit value to the encoder, perform the multi-term limit setting operation (Fn-013).

This operation can be executed using the hand-held digital operator or the servo amplifier panel operator.

Note: The multi-turn limit setting is enabled only during the multi-turn limit value mismatch alarm. Cycle the power after performing this operation.

! WARNING

- **Connect the ground terminal to a class-3 ground (100Ω less).**
Improper grounding may result in electric shock or fire.

5.7.3. Absolute Encoder Setup

Perform the setup operation for the absolute encoder in the following circumstances:

- When starting the machine for the first time.
- When an encoder backup alarm is generated.
- When the encoder loses power, often because of cable disconnection.

The setup operation can be performed by using personal computer monitor software.

The setup operation procedure shown here uses the digital operator. For more details, refer to *Chapter 7: Using the Panel Operator*.

1. Press the **MODE/SET** key to select the Auxiliary Function mode.

Fn000

2. Press the **Up Arrow ▲** or **Down Arrow ▼** key to select the parameter Fn008.

Fn008

3. Press the **DATA/SHIFT** key, holding it down for at least one second. The following display will appear.

PCLL1

4. Press the **Up Arrow ▲** key, holding it down until “PGCL5” is displayed. If an erroneous key entry is made, “nO_OP” will flash for one second, and the display will return to the Auxiliary Function mode. In that case, go back to step 3 above and perform the operation again.

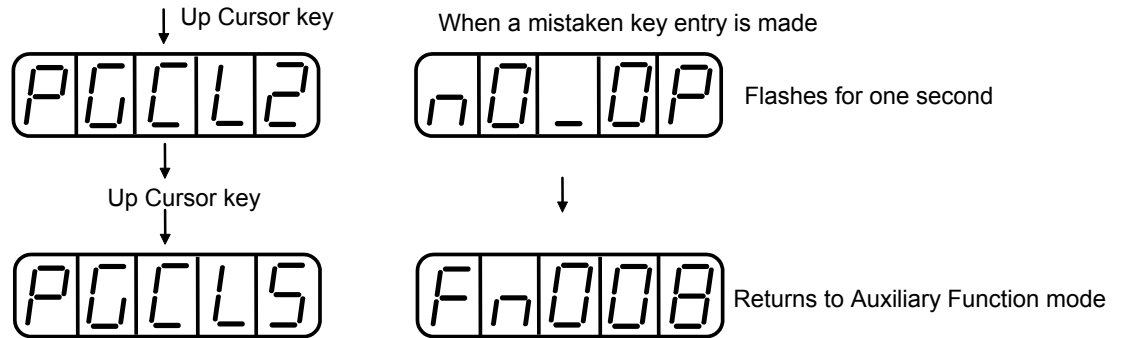

5. When “PGCL5” is displayed, press the **MODE/SET** key. The display will change as follows, and the absolute encoder’s multi-turn data will be cleared.

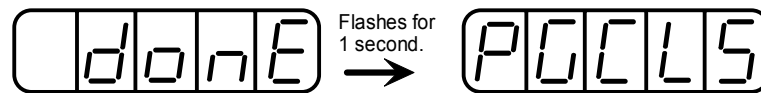

6. Press the **DATA/SHIFT** key to return to the Auxiliary Function mode.

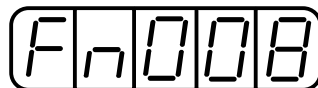

This completes the absolute encoder’s setup operation. Cycle the power to the servo amplifier.

Note: If the following absolute encoder alarms are displayed, the alarms must be cleared using the method described above for the setup operation. They cannot be cleared by the servo amplifier’s alarm reset (/ARM-RST) input signal.

- Encoder backup alarm (A.81)
- Encoder check sum alarm (A.82)

In addition, if a monitoring alarm is generated in the encoder, the alarm must be cleared by turning OFF the power.

■ Multi-turn Setup

1. Press the **MODE/SET** key to select the Auxiliary Function mode.

Fn000

2. Press the **Up Arrow ▲** or **Down Arrow ▼** key to select the parameter Fn013.

Fn013

3. Press the **DATA/SHIFT** key. The following display will appear.

PCCL6

4. Press the **MODE/SET** key. The display will change as follows, and the absolute encoder's multi-turn limit setting operation will be performed.

done Flashes for 1 second. → **PCSET**

5. Press the **DATA/SHIFT** key to return to the Auxiliary Function mode.

Fn013

This completes the absolute encoder's multi-turn limit setting operation. Cycle the power to the servo amplifier.

▲ WARNING

- **The multi-turn limit value should be changed only for special applications.** Changing it inappropriately or unintentionally can be dangerous.
- **If the Multi-turn Limit Value Disagreement Alarm occurs, check the setting of parameter Pn205 in the servo amplifier to be sure that it is correct. If Fn013 is executed when an incorrect value is set in Pn205, that same incorrect value will be set in the encoder. There will not be an additional alarm, even if an incorrect value is set, but incorrect positions will be detected.**
This results in a potentially dangerous situation where the machine will move to an unexpected position.

5.7.4. Absolute Encoder Reception Sequence

This section describes the sequence in which the servo amplifier receives data from the absolute encoder and transmits it to the host device. Be sure you understand this section when designing the host device.

■ Outline of Absolute Signals

The absolute encoder's outputs are PAO, PBO, PCO, and PSO signals as shown below.

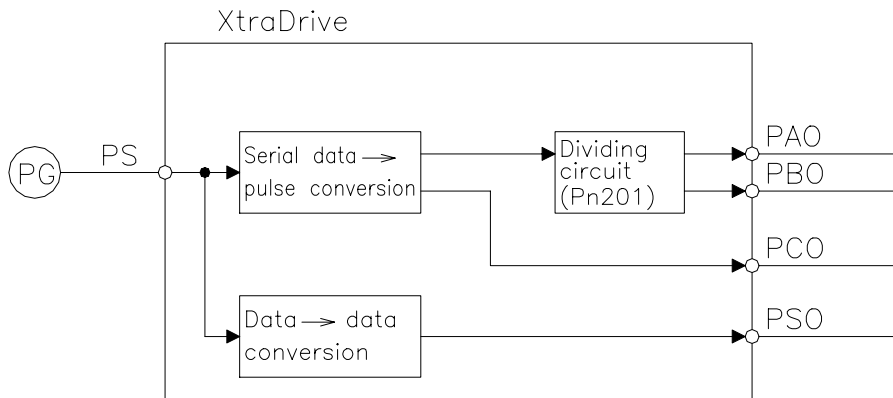

Signal	Status	Contents
PAO	Initial State	Serial data Initial incremental pulse
	Normal State	Incremental pulse
PBO	Initial State	Initial incremental pulse
PCO	Normal State	Incremental pulse
		Home position pulse
PSO		Rotation count serial data

■ Contents of Absolute Data

- Serial data: Indicates how many turns the motor shaft has made from the reference position (position specified at setup).
- Initial incremental pulse: Outputs pulses at the same pulse rate as when the motor shaft rotates from the home position to the current position at approximately 2500rpm (for 16 bits when the dividing pulse is at the default setting).

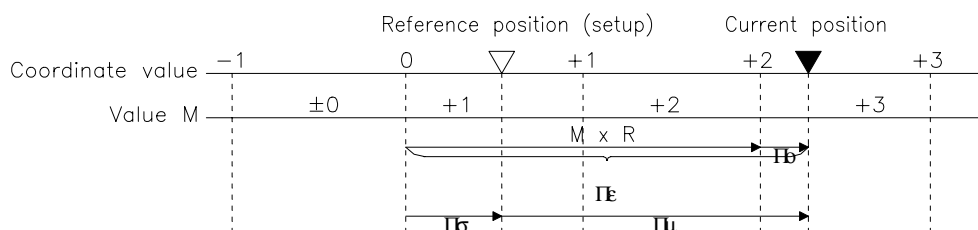

The final absolute data P_M can be found by using the following formulas:

Forward rotation mode:	$P_E = M \times R + P_O$ $P_M = P_E - P_S$	Reverse rotation mode: (Pn0000.0 = 1)	$P_E = -(M \times R) + P_O$ $P_M = P_E - P_S$
------------------------	--	--	---

- Where:
- P_E = The current value read by the encoder.
 - M = The multi-turn data (rotation count data).
 - P_O = The number of initial incremental pulses.
 - P_S = The number of initial incremental pulses read at setup.
(This is saved and controlled by the host controller).
 - P_M = The current value required for the user's system.
 - R = The number of pulses per encoder revolution.
(Pulse count after dividing by the value of Pn201)

■ Absolute Encoder Transmission Sequence

1. Set the SEN signal at high level.
2. After 100ms, set the system to serial data reception-waiting-state. Clear the incremental pulse up/down counter to zero.
3. Receive eight bytes of serial data.
4. The system enters a normal incremental operation state approximately 50ms after the last serial data is received.

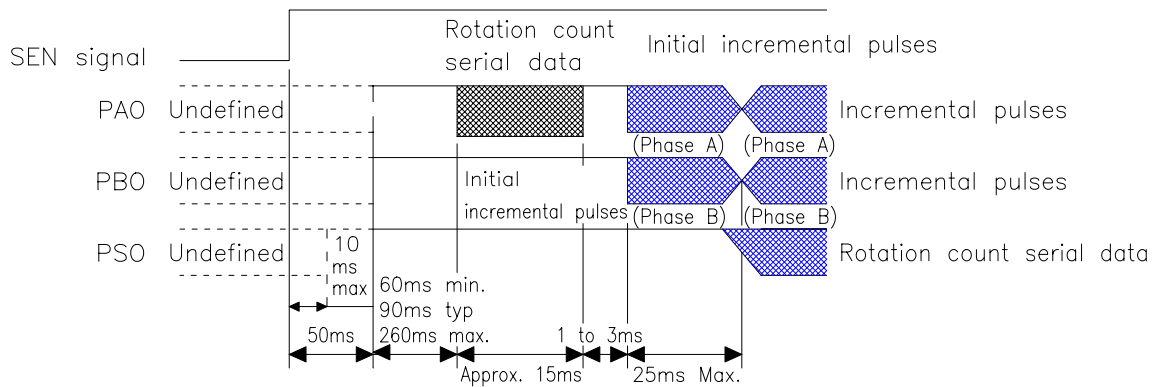

■ Detailed Signal Specifications

PAO Serial Data Specifications

The number of revolutions is output in five digits.

Data Transfer Method	Start-stop Synchronization (ASYNC)
Baud rate	9600bps
Start bits	1 bit
Stop bits	1 bit
Parity	Even
Character code	ASCII 7-bit code
Data format	8 characters, as shown below.

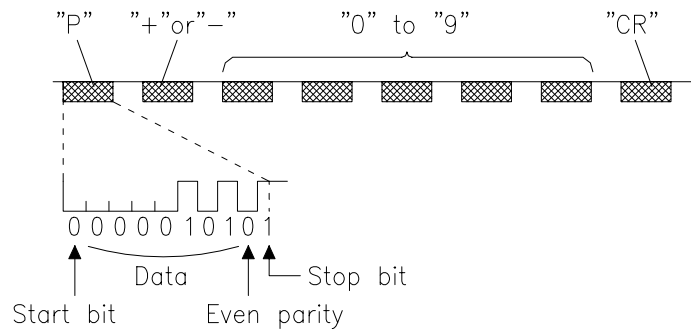

Note:

1. Data is "P+00000" (CR) or "P-00000" (CR) when the number of revolutions is zero.
2. The revolution range is "+32767" to "-32768." When this range is exceeded, the data changes from "+32767" to "-32768" or from "-32768" to "+32767"

PSO Serial Data Specifications

The number of revolutions and the absolute position within one revolution are always output in five and seven digits, respectively. The data output cycle is approximately 40ms.

Data Transfer Method	Start-stop Synchronization (ASYNC)
Baud rate	9600bps
Start bits	1 bit
Stop bits	1 bit
Parity	Even
Character code	ASCII 7-bit code
Data format	13 characters, as shown below.

Number of revolutions: "0" to "9" Absolute position within one revolution: "0" to "9"

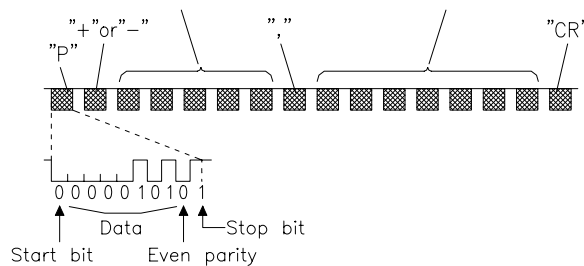

Note:

1. The absolute position data within one revolution is the value before dividing.
2. Absolute position data increases during forward rotation. (Not valid in reverse rotation mode).

Incremental Pulses and Origin Pulses

Just as with normal incremental pulses, initial incremental pulses which provide absolute data are first divided by the frequency divider inside the servo amplifier and then output.

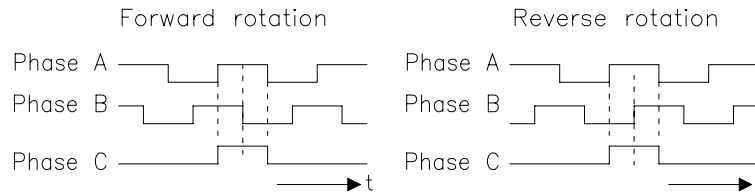

Setting the Pulse Dividing Ratio

Use the following parameter to set the pulse-dividing ratio.

Parameter	Signal	Setting (PPR)	Description
Pn201	PG Divider	Setting Range: 16 to 16384 Default Setting: 16384	Speed/Torque Control, Position Control

This parameter sets the number of output pulses for PG output signals (PAO, /PAO, PBO, /PBO).

Pulses from the motor encoder (PG) are divided by the number of pulses set here before being output.

The set value is the number of output pulses per revolution. Set this value according to the reference unit of the machine or controller to be used.

The setting range varies according to the encoder used.

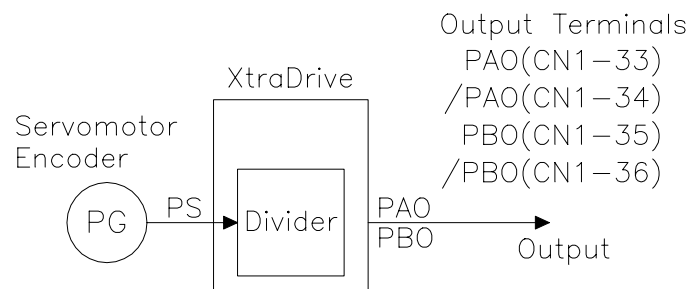

Setting Example

Set value:16

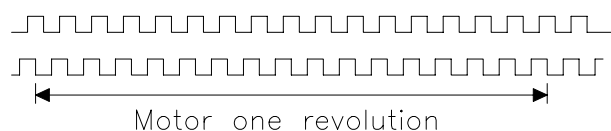

■ **Transferring Alarm Contents**

When an absolute encoder is used, SEN signals can be utilized to transfer the alarm contents through PAO outputs to the host device as serial data.

Alarm Contents Output Example		
SEN Signal		
Digital Operator Display		Absolute encoder backup alarm
PAO Serial Data		ALM81

Note: Refer to 9.2.3 *Alarm Display Table* for a table of alarm contents

5.8. AB Encoders

The XtraDrive supports both square wave (A quad B) and serial (Yaskawa's standard) encoder types. Yaskawa serial encoders are automatically detected by the XtraDrive and require no additional settings (please refer to chapter 5.7 for detailed information). In applications where standard A quad B encoders are used, certain parameters related to the motor and characteristics must be set manually. The following parameters should be set according to the specific encoder manually. Please note that these parameters become active only after restarting the driver.

Note: There are some parameters related to the motor electro-mechanical characteristics that cannot be set by the user. Contact the manufacturer in order to get a setup file containing these parameters.

First set the AB encoder by Pn190.2 to 1.

Pn190.2 Setting	Results
0	Yaskawa Serial Encoder
1	AB Encoder

Set Pn190.0 according to the following table:

Pn190.0 Setting	Results
0	Yaskawa AB model SGM
1	Yaskawa AB model SGMP
2	Other motor brand with A quad B encoder

Absolute/Incremental encoder. Set the following parameter to choose between an absolute encoder and an incremental encoder.

Pn190.1 Setting	Results
0	Incremental Encoder
1	Yaskawa absolute A quad B encoder

To use the absolute encoder properly you will need a battery that will power the encoder memory to keep its position.

C-pulse – Set the following parameter to choose between motor with and without C-pulse.

Pn190.3 Setting	Results
0	C-pulse used
1	C-pulse not used

Set the resolution of A quad B encoder in Pn192, Pn193. Note that the value in Pn192 should be set as the physical (optical) resolution, excluding the x4 multiplication done by the driver internally.

Parameter	Setting [pulses/rev]	Unit	Signal
Pn192	Setting range 0-9999 Default setting: 2048	Pulse / Rev.	Pulse number of A quad B encoder (Low bit)
Pn193	Setting range 0-419 Default setting: 0	Pulse*10000 / Rev.	Pulse number of A quad B encoder (High bit)

Set the direction of electrical phase. This parameter used to find the electrical phase in the AB encoder (other than Yaskawa); if you don't know the direction, just set unknown direction and XtraDrive will find it automatically.

Pn191.0 Setting	Results
0	Unknown direction
1	UVW
2	UWV

As mentioned before, the new parameter settings become active only after the driver has been restarted.

5.9. Configuration of Serial Commands for AB Encoders

5.9.1. Position Control

5.9.1.1. Defining User Units for Motion Profiles

XtraDrive's built-in programming capability enables the user to define various motion profiles without the need for an external motion controller. Having first defined the relationship between the actual encoder resolution and the units employed, the user uses units such as radians, millimeters, etc. to write motion commands. These user units (aka Engineering Units) are automatically converted by XtraDrive to encoder units.

Each user unit is comprised of three different factors: Position units, Speed units and Acceleration units, where each factor has both a numerator and a denominator.

5.9.1.2. Position Units

Use the following parameters to convert position units from [Encoder counts] to [User units]:

Parameter	Setting	Default Setting	Signal
Pn2B0	Setting range 1-65535	1	Position units ratio numerator
Pn2B1	Setting range 0-16383	0	Position units ratio numerator (high bits*)
Pn2B2	Setting range 1-65535	1	Position units ratio denominator
Pn2B3	Setting range 0-16383	0	Position units ratio denominator (high bits*)

Position user units are calculated according to the formula:

$$1 \text{ [User Position Unit]} = U \text{ [counts]} = \frac{\text{Position units ratio numerator}}{\text{Position units ratio denominator}}$$

U – The number of encoder counts in each user position unit.
The number need not be an integer.

The maximum value of numerator (Pn2B0) or denominator (Pn2B2) is 65535. In cases where greater values are required, it is possible to use parameters Pn2B1 and Pn2B3 for storing the high bits of numerator and denominator, respectively, according to the following formula:

$$\begin{aligned} \text{High Bits} = \text{HB} &= \text{Integer part of } \frac{N}{65536} \\ \text{Low Bits} &= N - \text{HB} \cdot 65536 \end{aligned}$$

where N - required value.

Example:

A rotary motion system uses a motor with a 17-bit encoder. The user wants to program the system in units of 0.1 degree:

17-bit encoder produces 131072 [counts] per revolution.

360 [degree] = 3600 [0.1 degree]

$$1 [0.1 \text{ degree}] = \frac{131072}{3600} [\text{counts}] = \frac{\text{Position units ratio numerator}}{\text{Position units ratio denominator}}$$

First option:

It is possible to reduce the fraction so that both the numerator and denominator are smaller than 65536:

$$131072 / 3600 = 32768 / 900$$

→ Reduction

$$\text{Pn2B0} = 32768$$

$$\text{Pn2B1} = 0$$

$$\text{Pn2B2} = 900$$

$$\text{Pn2B3} = 0$$

Second option:

Without reduction of the fraction:
High Bits = HB = Integer part of $N/65536 = \text{Integer part of } 131072 / 65536 = 2$

$$\text{Low Bits} = N - \text{HB} \cdot 65536 = 131072 - 2 \cdot 65536 = 0$$

$$\text{Pn2B0} = 0$$

$$\text{Pn2B1} = 2$$

$$\text{Pn2B2} = 3600$$

$$\text{Pn2B3} = 0$$

Both options are equivalent.

5.9.1.3. Speed Units

Use the following parameters to convert speed units from [encoder counts/msec] to [user speed units]:

Parameter	Setting	Default Setting	Signal
Pn2B4	Setting range 1-65535	1	Speed units ratio numerator
Pn2B5	Setting range 0-16383	0	Speed units ratio numerator (high bits*)
Pn2B6	Setting range 1-65535	1	Speed units ratio denominator
Pn2B7	Setting range 0-16383	0	Speed units ratio denominator (high bits*)

Speed user units are calculated according to the formula:

$$1 [\text{User speed unit}] = \left[\frac{U [\text{counts}]}{T [\text{ms}]} \right] = \left[\frac{\text{Speed units ratio numerator}}{\text{Speed units ratio denominator}} \right]$$

U – number of encoder counts in one speed unit.

T – time of speed units in ms.

The maximum value of numerator (Pn2B4) or denominator (Pn2B6) is 65535. In cases where greater values are required, it is possible to use parameters Pn2B5 and Pn2B7 for storing the high bits of numerator and denominator, respectively, according to the following formula:

$$\text{HighBit} = \text{HB} = \text{Integer part of } \frac{N}{65536}$$

$$\text{LowBits} = N - \text{HB} \cdot 65536, \text{ where } N - \text{required value.}$$

Example:

A rotary motion system uses a motor with a 17-bit encoder. The user wants to program the system in speed units of rpm:

17-bit encoder produces 131072[counts] per revolution.

$$U=131072$$

$$1[\text{minute}]=60000[\text{ms}]$$

$$T=60000$$

$$1[\text{rpm}] = \frac{U[\text{counts}]}{T[\text{ms}]} = \frac{131072[\text{counts}]}{60000[\text{ms}]} = \left[\frac{\text{Speed units ratio numerator}}{\text{Speed units ratio denominator}} \right]$$

First option:

It is possible to reduce the fraction so that both the numerator and denominator are smaller than 65536:
 $131072 / 60000 = 32768 / 15000$
 → Reduction
 $Pn2B4 = 32768$
 $Pn2B5 = 0$
 $Pn2B6 = 15000$
 $Pn2B7 = 0$

Second option:

Without reduction of the fraction:
 High Bits = HB = Integer part of $N/65536 = \text{Integer part of } 131072 / 65536 = 2$
 Low Bits = $N - HB * 65536 = 131072 - 2 * 65536 = 0$
 $Pn2B4 = 0$
 $Pn2B5 = 2$
 $Pn2B6 = 60000$
 $Pn2B7 = 0$

Both options are equivalent.

5.9.1.4. Acceleration Units

Use the following parameters to convert acceleration units from [encoder counts/(10msec)²] to [user acceleration units]:

Parameter	Setting Range	Default Setting	Signal
Pn2B8	1-65535	1	Acceleration units ratio numerator
Pn2B9	0-16383	0	Acceleration units ratio numerator (high bits*)
Pn2BA	1-65535	1	Acceleration units ratio denominator
Pn2BB	0-16383	0	Acceleration units ratio denominator (high bits*)

Acceleration user units are calculated according to the formula:

$$1[\text{User acceleration unit}] = \frac{U[\text{counts}]}{T^2[(10 * \text{ms})^2]} = \left[\frac{\text{Acceleration ratio numerator}}{\text{Acceleration ratio denominator}} \right]$$

where:

U - represents the number of encoder counts in one acceleration unit.

T - represents the time of acceleration unit in (10*ms)

The maximum value of numerator (Pn2B8) or denominator (Pn2BA) is 65535. In cases where greater values are required, it is possible to use parameters Pn2B9 and Pn2BB for storing the high bits of numerator and denominator respectively according to the following formula:

$$\begin{aligned} \text{High Bits} = \text{HB} &= \text{Integer part of } \frac{N}{65536} \\ \text{Low Bits} &= N - \text{HB} * 65536 \end{aligned}$$

Where N – required value

Example:

A rotary motion system uses a motor with a 17-bit encoder. The user wants to program the system in units of rad/s²:

17-bit encoder produces 131072[counts] per revolution.

One revolution = 2π [rad]

$$U = 131072 / 2\pi$$

$$1 \text{ [s]} = 1000[\text{ms}] = 100[10*\text{ms}] = T$$

$$T^2 = 10000$$

$$1[\text{rad}/\text{sec}^2] = \frac{U[\text{counts}]}{T^2[(10*\text{ms})^2]} = \frac{131072}{2\pi * 10000} = \frac{131072}{62832} = \left[\frac{\text{Acceleration units ratio numerator}}{\text{Acceleration units ratio denominator}} \right]$$

Example:

Without reduction of the fraction:
 High Bits = HB = Integer part of N/65536 = Integer part of 131072/65536 = 2
 Low Bits = N – HB * 65536 = 131072 – 2 * 65536 = 0
 Pn2B8 = 0
 Pn2B9 = 2
 Pn2BA = 62832
 Pn2BB = 0

5.9.1.5. Setting Default Motion Profile Parameters

When using position control with serial commands, the user downloads the movements from the host using the XtraWare software (see *Section 4.3, Programming the XtraDrive* in the XtraWare User's Manual). XtraDrive has variables that define the motion profile. Initially the defaults of the Motion Profile Parameters are as described below. However, they can be modified through the host or by the program after the XtraDrive is turned ON.

Some of these profile features are long and are therefore stored in two parameters: the high bit parameter contains the integer part of the value divided by 65536, and the low bit parameter contains the remainder from this calculation.

5.9.1.6. Profile Speed (Pn2A2, Pn2A3)

These parameters are used to define the default value of the profile speed variable. This variable is used to reach a target within a minimum period of time (set the time of movement to -1). The driver accelerates until it reaches this profile speed.

Parameter	Setting	Units	Default Setting	Signal
Pn2A2	Setting range 0-65535	User Speed	0	Work speed default
Pn2A3	Setting range 0-256	User Speed*65536	0	Work speed default

For example, for a profile speed of 200000 [Speed units], set the following parameters:

- $Pn2A3 = \text{integer part of } 200000 / 65536 = 3$
- $Pn2A2 = 200000 - 3 * 65536 = 3392$

5.9.1.7. Profile Acceleration (Pn2A4, Pn2A5)

These parameters are used to define the default value of the profile acceleration variable. This variable is used in Position mode whenever the motor accelerates.

Parameter	Setting	Signal
Pn2A4	Setting range 0-65535 Default setting: 0 [User Acceleration units]	Work acceleration default
Pn2A5	Setting range 0-256 Default setting: 0 [User Acceleration units*65536]	Work acceleration default

For example, for a profile acceleration of 200000 [Acceleration units], set the following parameters:

- $Pn2A4 = \text{integer part of } 200000/65536 = 3$
- $Pn2A5 = 200000 - 3*65536 = 3392$

5.9.1.8. Jerk Smoothing Time (Pn2A6)

This parameter is used to define the default value of the jerk smoothing time variable. This variable is used to define the jerk smoothing time of a movement, i.e., it uses an average filter on the command pattern. For example, if the command pattern is a trapeze, it will make it a S-curve pattern.

Parameter	Setting [micro sec]	Signal
Pn2A6	Setting range 0-65535 Default setting: 0	Work jerk smoothing time default

5.9.1.9. Quick Stop Deceleration (Pn2A8, Pn2A9)

These parameters are used to define the deceleration of the motor when a STOP command is issued.

Parameter	Setting	Signal
Pn2A8	Setting range 0-65535 Default setting: 65535 [User Acceleration units]	Deceleration of motor in case of STOP command
Pn2A9	Setting range 0-256 Default setting: 256 [User Acceleration units*65536]	Deceleration of motor in case of STOP command

For example, for a deceleration of 200000 [Acceleration units], set the following parameters:

- $Pn2A8 = \text{integer part of } 200000/65536 = 3$
- $Pn2A9 = 200000 - 3*65536 = 3392$

5.9.1.10. Motion End Window (Pn2C0)

This variable defines the default value of a window for position error to finish a motion. In case of a MOVED motion, the next motion in buffer will be executed after the command is finished and the position error (in user units) will be smaller than the value of this variable.

Parameter	Setting [User position units]	Signal
Pn2C0	Setting range:0-250 Default setting:10	Motion end window default

5.9.2. Torque Control

5.9.2.1. Torque Slope (Pn2C1)

This parameter defines the default value for maximum torque variation. If the host sends a torque command, the actual torque will be smoothed by this rate and will not make a step in torque.

Parameter	Setting [0.1% of rated torque/ms]	Signal
Pn2C1	Setting range 1-8000 Default setting: 8000	Torque slope

5.9.3. Homing

For serial commands, the homing procedure is different. You will need a host (PC) to perform the procedure.

To perform the homing procedure, proceed as follows:

1. Move the motor to its home position (see parameters below for this command).
2. Run command from PC (SET ZERO POSITION) to write the value of the encoder into the following parameters: Pn2C2 and Pn2C3. It takes two parameters to save a 32-bit encoder's value. After this command, the motor position at home position will be zero. The absolute encoder uses the value of the parameters as the offset to home position. If you are using an incremental encoder, you do not need to run this command from the PC because the encoder does not remember its position and does not use these parameters.

Note: If after home (in absolute encoder), the command SET ZERO POSITION does not execute, then no offset is added to encoder.

It is possible to find home in two ways: either by a limit switch or by an obstacle (hard home). Hard home is found if two conditions are valid: if motor speed dropped below a certain value (Pn2C5) and if torque raised to a certain limit as specified in HARD_HOME command variable (refer to the XtraWare User's Manual P/N 8U0109)

Parameter	Setting	Signal
Pn2C5	Setting range 0-32000 Default setting: 2 [Speed units]	Define the zero speed when searching hard home

Home flags – To use a limit switch, define the following:

- Input for this limit switch by Pn2C7.0

Pn2C7.0 Setting	Results (Home Switch Input)
0	SI0 (CN1-40) (default)
1	SI1 (CN1-41)
2	SI2 (CN1-42)
3	SI3 (CN1-43)
4	SI4 (CN1-44)
5	SI5 (CN1-45)
6	SI6 (CN1-46)
7-F	Home failure

Pn2C7 Setting	Results (Limit Switch Polarity)
0	Home switch input (0-F)
1	Reserved
2	Reserved
3	Reserved

5.9.4. Digital I/O

In addition to the digital input parameters Pn50A – Pn50D, there is one more input for serial commands, Pn2D1 that work in the same way and can be related in the program.

You can define Emergency input to set servo OFF. Just define in parameter Pn2D1.0 the input for this emergency.

Pn2D1.0 Setting	Results (Emergency Input)
0	SI0 (CN1-40)
1	SI1 (CN1-41)
2	SI2 (CN1-42)
3	SI3 (CN1-43)
4	SI4 (CN1-44)
5	SI5 (CN1-45)
6	SI6 (CN1-46)
7	Set Emergency always OFF
8	Set Emergency always ON (default)

Note: In case of Pn2D1.0=8 you cannot set servo ON, because Emergency is always ON.

In addition to digital output parameters Pn50E – Pn50F, there is one more output for serial command defined in Pn2D2 that work in the same way and can be related in the program.

Parameter	Results
Pn2D2.0	COIN signal
Pn2D2.1	Reserved
Pn2D2.2	Reserved
Pn2D2.3	Reserved

Pn2D2.0 is defined as the position complete output signal in serial command (Position Control). It indicates when the motor has reached the target position.

Pn2D2.0 Setting	Results (Output From)
0	Disabled
1	SO1 (CN1-25,26) (default)
2	SO2 (CN1-27,28)
3	SO3 (CN1-29,30)

5.9.5. Auto Tuning

For the auto tuning procedure refer to the XtraWare User Manual. Auto Tuning is performed by moving forward and reverse, while parameters are being tuned. The following parameters define the profile of this movement.

Parameter	Setting	Signal
Pn2C8	Setting range 200-2000 Default setting: 400 [ms]	Delay between two movements of automatic tuning (t_1)
Pn2C9	Setting range 0-100 Default setting: 50 [% of maximum speed]	Define the maximum speed of auto tuning movements.
Pn2CA	Setting range 0-1000 Default setting: 50 [ms]	Define the time of acceleration to reach the maximum speed of the movement. (t_2)
Pn2CB	Setting range 0-1000 Default setting: 50 [ms]	Define the plateau time (time of constant speed) of auto tuning movement. (t_3)

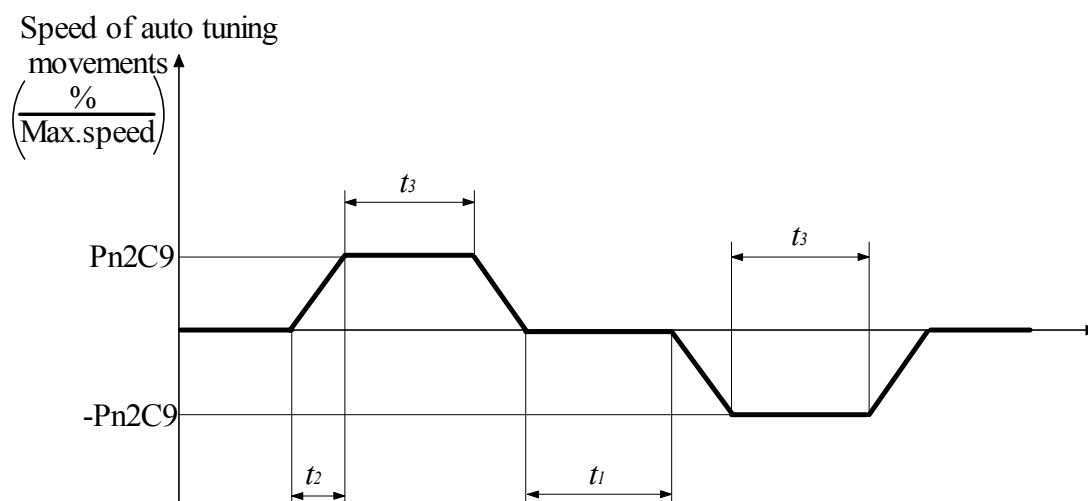

5.10. Auto Running a User Program

After downloading a user program to the driver, it is possible to run it automatically every time the driver turns ON, by setting the parameter Pn2CC to the program label number which the program start with. With the default setting 0 the program auto running is disabled.

Parameter	Setting	Results
Pn2CC	Setting range: 0 to 99 Default setting: 0 (auto run disabled)	Starts user program automatically at settled label when turning ON XtraDrive's power.

6. Servo Adjustment

This chapter describes the functions required for servo adjustment. Find the required information by selecting the section from the following table of contents.

6.1.	Selection of Control Mode.....	6-2
6.2.	Analog Input or Contact Input Velocity Control.....	6-3
6.2.1.	Principle and Block Diagram of the Velocity Control.....	6-3
6.2.2.	Parameters of the Velocity Control.....	6-4
6.2.3.	Setting the Input Gain.....	6-4
6.2.4.	Adjusting Offset.....	6-5
6.2.5.	Using the Soft Start Function.....	6-6
6.2.6.	Load Inertia Setting.....	6-7
6.2.7.	Adjusting Speed Loop Gain.....	6-8
6.2.8.	Setting the Torque Reference Filter Time Constant.....	6-9
6.2.9.	Notch Filter.....	6-9
6.2.10.	Gain Setting Reference Values.....	6-10
6.3.	NCT Position Control.....	6-12
6.3.1.	Load Inertia Setting.....	6-12
6.3.2.	Position Control Block Diagram.....	6-14
6.3.3.	NCT Gain Parameters.....	6-15
6.3.4.	OCA - Oscillation Canceling Algorithm.....	6-16
6.3.5.	Additional Parameters Tuning.....	6-17
6.3.6.	Filters.....	6-17
6.3.7.	Flexible System Parameters.....	6-18
6.3.8.	Gain Factor.....	6-19
6.3.9.	Integral Clear Parameters.....	6-19
6.3.10.	Tuning Procedure for Position Control Parameters.....	6-20
6.4.	Analog Monitor.....	6-22

6.1. Selection of Control Mode

The XtraDrive servo amplifier offers speed control, position control, torque control, and the other control modes shown in the following table.

The following parameter is used to set the control mode.

Parameter	Signal	Setting	Control Mode
Pn000.1	Control Method Selection	Default Setting: D	Speed/Torque Control, Position Control

Pn000.1 Setting	Control Mode
0	Speed Control (Analog Reference)
2	Torque Control (Analog Reference)
3	Contact Input Speed Control Selection (Contact Reference)
4	Contact Input Speed Control Selection (Contact Reference) ↔ Speed Control (Analog Reference)
6	Contact Input Speed Control Selection (Contact Reference) ↔ Torque Control (Analog Reference)
8	Position Control (Pulse Train Reference) ↔ Torque Control (Analog Reference)
9	Torque Control (Analog Reference) ↔ Speed Control (Analog Reference)
A	Speed Control (Analog Reference) ↔ Zero Clamp Control
B	Position Control (Pulse Train Reference) ↔ Position Control (Inhibit)
C	Position Control (Pulse Train Reference)
D	NCT Position Control, NCT Speed Control, Torque Control (Serial Communication Command)

Whenever Speed Control or Position Control is selected, the Loop Gain parameters should be adjusted in order to ensure a stable and smooth operation.

Adjustment of Speed Control using Analog Input or Contact Input is described below in section 6.2, for setting cases of Pn000.1 = 0, 3, 6, 9 and A.

Adjustment for Position Control or NCT Velocity Control is described below in section 6.3, for setting cases of Pn000.1=8, B, C and D.

6.2. Analog Input or Contact Input Velocity Control

This section provides technical information for operation of servomotors in Velocity Control mode with Analog Input.

The Identical Control principle is applied in case of Contact Input or Analog Input. In case of Contact Input, the velocity command value is retrieved from one of the predefined values, according to the Contact Input setting.

Instructions and descriptions referring to Analog Input in the following sections also apply to Contact Input.

6.2.1. Principle and Block Diagram of the Velocity Control

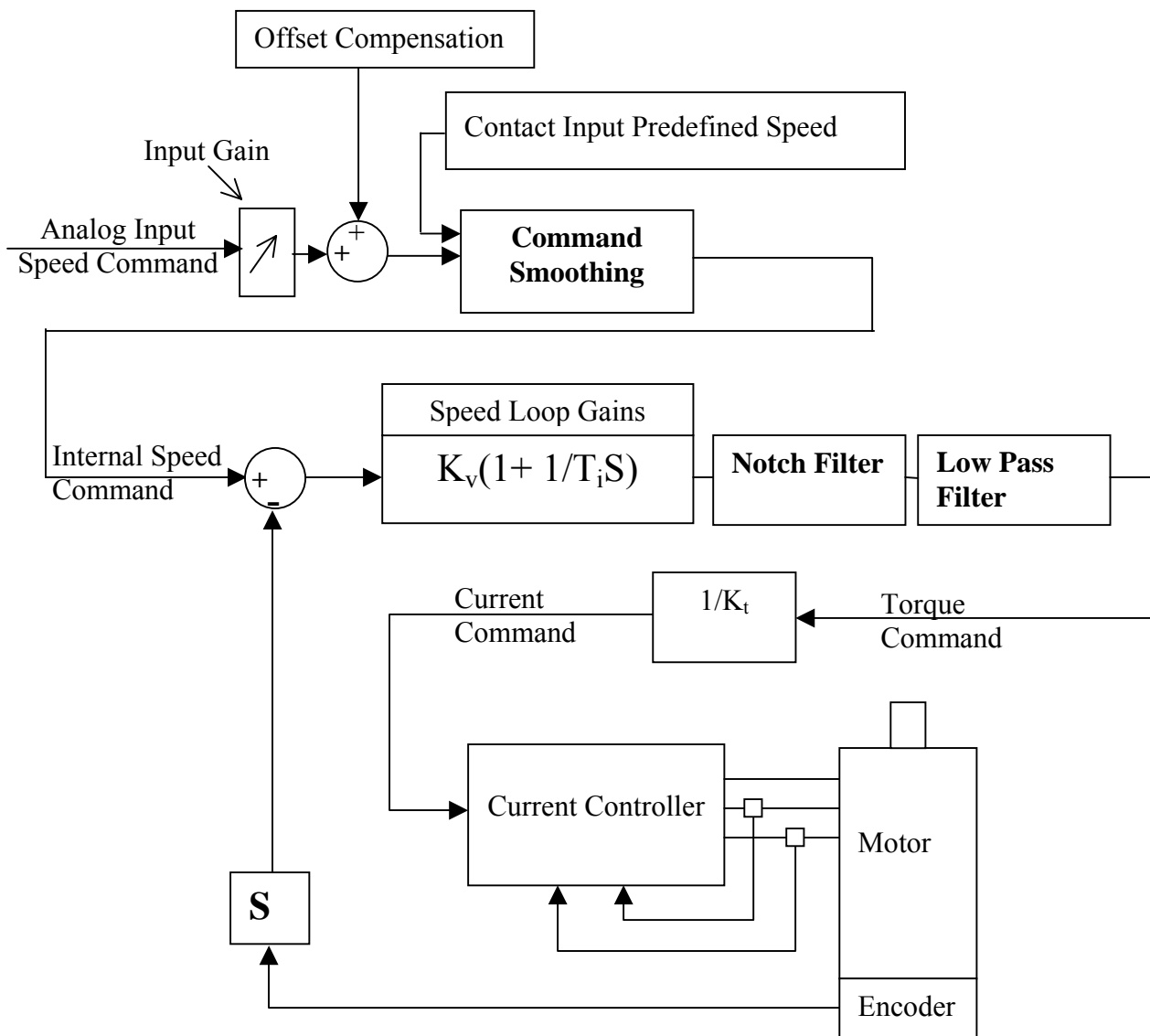

The Velocity Command is first processed in order to smooth the operation. The resulting Internal Speed Command is then compared with the actual speed of the motor. The difference is then amplified and filtered to produce a Torque and Current command for the Current Controller.

6.2.2. Parameters of the Velocity Control

The following parameters are related to Velocity Control:

- Pn305 → Soft Start Acceleration time
- Pn306 → Soft Stop Deceleration time
- Pn103 → Inertia Ratio
- Pn300 → Speed Reference Input gain
- Pn100 → Speed Loop Gain
- Pn101 → Speed Loop Integral Time constant
- Pn401 → Torque Reference Filter Time Constant
- Pn408.0 → Notch Filter activation
- Pn409 → Notch Filter Frequency
- Pn40A → Notch Filter Width

6.2.3. Setting the Input Gain

Parameter 300 defines the ratio between Analog Voltage and equivalent speed command.

Normally, this parameter should be set so that a 10Volt input will produce a speed command slightly superior to the maximum allowable speed of the system.

The units of that parameter are $(0.01\text{Volt})/(\text{Rated Speed})$

*Example: With the default setting 600,
6Volt input will result in a rated speed command.*

6.2.4. Adjusting Offset

The servo system does not operate smoothly if reference voltage from the host controller or external equipment has a reference offset value close to 0V. In that case, adjust the reference offset value to 0V.

■ Reference Voltage Offset from Host Controller or External Circuitry

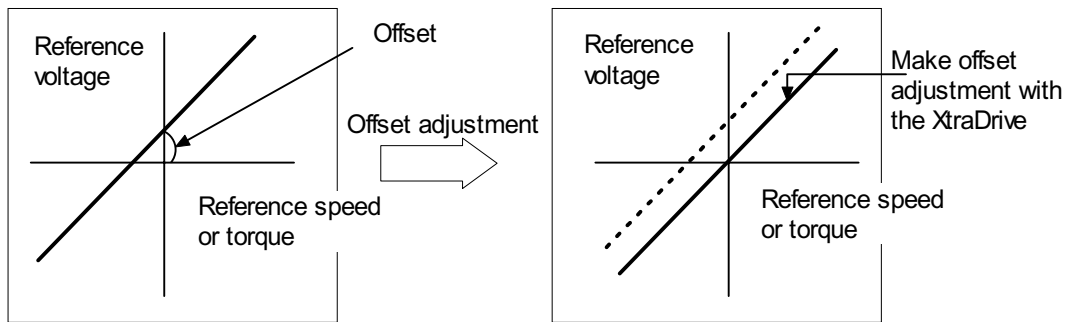

■ Reference Offset Adjustment

The following two methods are provided to reset the reference offset value to 0V.

- Reference offset automatic adjustment
- Reference offset manual adjustment

If a position loop is formed in the host controller, be sure to make a manual offset adjustment and no automatic reference offset adjustment.

Refer to the following sections in *Chapter 7 Using the Panel Operator* for a detailed description of reference offset adjustment.

Adjustment Method	Detailed Description
Automatic	7.2.3 Automatic Adjustment of the Speed and Torque Reference Offset
Manual	7.2.4 Manual Adjustment of the Speed and Torque Reference Offset

6.2.5. Using the Soft Start Function

The soft start function adjusts progressive speed reference input inside the servo amplifier so that acceleration and deceleration can be as constant as possible. To use this function, set the following parameters.

Parameter	Signal	Setting (ms)	Description
Pn305	Soft Start Acceleration Time	Setting Range: 0 to 10000 Default Setting: 0	Speed Control
Pn306	Soft Start Deceleration Time	Setting Range: 0 to 10000 Default Setting: 0	Speed Control

In the servo amplifier, a speed reference is smoothed by the acceleration or deceleration value set in Pn305 or Pn306 to provide speed control.

The soft start function enables smooth speed control when non-progressive speed references are input or when contact input speed control is used.

Set both Pn305 and Pn306 to “0” for normal speed control, i.e when the speed reference does not need to be smoothed.

Set these parameters as follows:

- Pn305: The time interval from the time the motor starts until the maximum speed is reached.
- Pn306: The time interval from the time the motor is operating at the maximum speed until it stops.

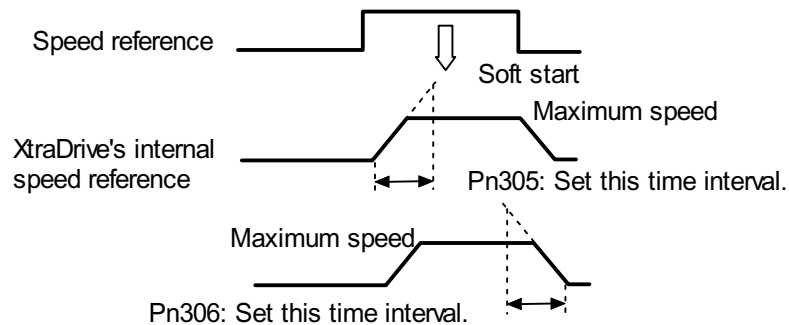

6.2.6. Load Inertia Setting

In order to use values of Loop Gains that are closely related to the characteristics of your system, loop gains are normalized in Hertz. This normalization of parameters is done according to the assumed inertia of the system.

You should do a rough estimation of the inertia of the load for your system and input its value in the Load Inertia Ratio parameter (Pn103).

Set Pn103 to the following value.

$$Pn103 = \frac{\text{Motor Load Inertia } (J_L)}{\text{Servomotor Rotor Inertia } (J_M)} \times 100\%$$

Parameter	Signal	Setting (%)	Application
Pn103	Inertia Ratio	Setting Range: 0 to 10000 Default Setting: 0	Speed/Torque Control, Position Control

The following shows how to calculate the Load Inertial ratio for different mechanical systems:

Estimation of Equivalent Load (J_{load})

Case 1_ Load is a cylinder directly mounted or coupled to the motor axis:

$$J_{load} = \frac{\pi \times \rho \times l \times d^4}{32}$$

ρ is the density of the load material[kg/m³].

L is the length

D is the diameter of the load [m].

Case 2_ Load is driven through a gear with ratio N:

Equivalent load on motor is:

$$J_{load} = \frac{J}{N^2}$$

Case 3: Load is a mass driven by a ball screw having pitch:

$$J_{load} = M \times \text{Pitch}^2 + J_{screw} + J_{coupling}$$

J_{load} , \rightarrow Kg.m² , M \rightarrow Kg, Pitch \rightarrow meter/radian

Other Cases: Make your own rough load inertia evaluations.

6.2.7. Adjusting Speed Loop Gain

The adjustment of Speed Loop Gains is an iterative process in interaction with the adjustment of Notch Filter and Torque Filter. Before executing it, you should read sections 6.1.7 and 6.1.8.

The purpose of the Speed Control is to maintain the Speed Error, i.e. the difference between Internal Speed Command and Actual Speed, as small as possible.

This is obtained by raising the Speed Loop Gain K_v (Pn100) and the Speed Loop Integration time T_i (Pn101).

However, if K_v is too high, or T_i is too small, oscillations may occur. Usually, a too high K_v will produce high frequency oscillations, while a too small T_i will produce lower frequency oscillations.

Parameter	Signal	Setting	Application
Pn100	Speed Loop Gain (K_v)	Setting Range: 1 to 2000Hz Default Setting: 40Hz	Speed/Torque Control
Pn101	Speed Loop Integral Time Constant (T_i)	Setting Range: 15 to 51200 x 0.01ms Default Setting: 2000 x 0.01ms	Speed/Torque Control

Tuning can be done by observing the load and listening to the acoustic noise of the eventual vibrations. For more precise tuning, you may monitor the velocity error using an oscilloscope and the analog monitoring outputs provided by the XtraDrive. *Refer to Section 6.4*

The tuning procedure is as follows:

1. Start with a T_i at maximum value and a low value of K_v , so that system will be stable upon Servo Enabling.
2. Enable the Servo, then progressively rise the value of K_v , until oscillations or overshoots are observed.
3. Decrease K_v by about 10 to 20%.
4. Decrease T_i until lower frequency oscillations or overshoots are observed, then raise T_i back by about 20%

In the particular case where position control is done in a host system and outputs an Analog command for feedback:

It is possible to increase input gain in order to increase the position loop gain of your system.

These tuning steps should be repeated each time torque filter or notch filter settings are modified.

If torque filter and notch filter are optimally tuned, then loop gain can be raised to a higher value, and the speed error will be smaller.

6.2.8. Setting the Torque Reference Filter Time Constant

If there is machine vibration, which may be caused by the servo drive, try adjusting the filter time constant in Pn401. This may stop the vibration.

Parameter	Signal	Setting (x 0.01ms)	Application
Pn401	Torque Reference Filter Time Constant	Setting Range: 0 to 65535 Default Setting: 100	Speed/Torque Control, Position Control

The constant above is the filter time constant of the torque reference to be set in the servo amplifier. The smaller the value, the faster the speed control response will be. There is, however, a limit, depending on machine conditions.

In order to find the optimal value of the torque filter, repeat steps 1 and 2 of previous section for each new try of the torque filter. Finally select the optimal torque filter value as the one who results in the highest Kv.

6.2.9. Notch Filter

Vibration in the machine can sometimes be eliminated by using a notch filter for the frequency at which the vibration is occurring.

Parameter	Signal	Setting	Application
Pn408.0	Notch Filter Selection	Default Setting: 0	Speed/Torque Control, Position Control

This parameter can be set to enable the notch filter.

Pn408.0 Setting	Result
0	None.
1	Enables notch filter for torque reference.
2	Use net notch (not implemented)
3	Use both.

Use the following parameter to set the frequency at which the filter is effective.

Parameter	Signal	Setting(Hz)	Application
Pn409	Notch Filter Frequency	Setting Range: 50 to 2000 Default Setting: 2000	Speed/Torque Control, Position Control
Pn40A	Notch Filter Width	Setting Range: 70 to 1000 Default Setting: 70	Speed/Torque Control, Position Control

6.2.10. Gain Setting Reference Values

This section describes servo gain reference values.

Refer to the following for optimal gain adjustments according to the rigidity of the mechanical system. Refer to these values and use the previously mentioned methods to make gain adjustments. These values are for reference only and do not mean that the mechanical system has good response characteristics or is free from oscillation in the specified ranges.

Observe the response by monitoring the response waveform and make the optimal gain adjustments. If the rigidity of the machinery is high, gain increments exceeding the described ranges are possible.

■ Machines with High Rigidity

These machines are directly connected to ball screws.

Examples: Chip mounting machine, bonding machine, and high-precision machine tool

Speed Loop Gain (Pn100)	Speed Loop Integral Time Constant (Pn101)
50 to 70Hz	5 to 20ms

■ Machines with Medium Rigidity

Machines driven by ball screws through speed reducers or long-length machines directly driven by screws.

Examples: General machine tool, transverse robot, and conveyor

Speed Loop Gain (Pn100)	Speed Loop Integral Time Constant (Pn101)
30 to 50Hz	10 to 40ms

■ Machines with Low Rigidity

These machines are driven by timing belts, chains or machines with harmonic gear reducers.

Examples: Conveyor and articulated robot

Speed Loop Gain (Pn100)	Speed Loop Integral Time Constant (Pn101)
10 to 20Hz	50 to 120ms

IMPORTANT

- When the inertia ratio is larger than 10, start gain adjustments with the position and speed loop gains slightly below the ranges given above and the speed loop integral constant slightly over the range.
- When the inertia ratio is much larger, start the gain adjustments with the position and speed loop gains set to the smallest values and the speed loop integral constant to the largest value in the ranges given above.

In speed control operation, the position loop gain is set through the host controller. If that is not possible, adjust the position loop gain with the speed reference input gain in Pn300 in the servo amplifier. In speed control operation, the position loop gain set in Pn102 is enabled in zero-clamp mode only. Position loop gain K_p can be obtained from the following formula.

$$K_p \geq \frac{V_s}{\varepsilon}$$

Where: K_p (s^{-1}) : Position Loop Gain

V_s (pps) : Constant Speed Reference

ε (Pulse) : Constant Error: The number of accumulated pulses of the error counter at the above constant speed.

6.3. NCT Position Control

Position control can be performed by PULSE TRAIN (Pn000.1=C) or by SERIAL commands (Pn000.1=D).

XtraDrive provides an automatic tuning function. In case of auto-tuning, only a rough estimation of load inertia is required. Refer to *Section 6.3.2* for the evaluation of the load inertia, then to *Section 5.9.5* for the activation of the Auto-tuning function.

6.3.1. Load Inertia Setting

In order to use values of loop gains that are closely related to the physical characteristics of your system, the loop gains are normalized in Hertz. This normalization of parameters is done according to the assumed inertia of the system.

Furthermore, the controller includes an automatic set up procedure that set parameters according to load size. This setting will be satisfactory in most cases. In case more precise tuning is desired, this first set can be used as a starting point

You can do a rough estimation of the inertia of the load for your system and input its value in the Load Inertia Ratio parameter (Pn103).

Set Pn103 to the following value:

$$Pn103 = \frac{\text{Motor Load Inertia (J}_L\text{)}}{\text{Servomotor Rotor Inertia (J}_M\text{)}} \times 100\%$$

Parameter	Signal	Setting (%)	Application
Pn103	Inertia Ratio	Setting Range: 0 to 10000 Default Setting: 0	Speed/Torque Control, Position Control

The following wizard will help you to calculate your load inertia.

Estimation of Equivalent Load (J_{load})

Case 1_ Load is a cylinder directly mounted or coupled to motor axis:

$$J_{load} = \frac{\pi \times \rho \times l \times d^4}{32}$$

ρ is the density of the load material [kg/m³]

L is the length

D is the diameter of the load [m]

Case 2_ Load is driven through a gear with ratio N:

Equivalent load on motor is:

$$J_{load} = \frac{J}{N^2}$$

Case 3: Load is a mass driven by a ball screw having pitch:

$$J_{load} = M \times Pitch^2 + J_{screw} + J_{coupling}$$

J_{load} → Kg.m² , M → Kg, Pitch → meter/radian

Other Cases: Make your own rough load inertia evaluations.

6.3.2. Position Control Block Diagram

The following is a general block diagram of the NCT. The NCT algorithm includes specific non-linear functions for each one of the blocks shown here, so that this block diagram should be used for general understanding only.

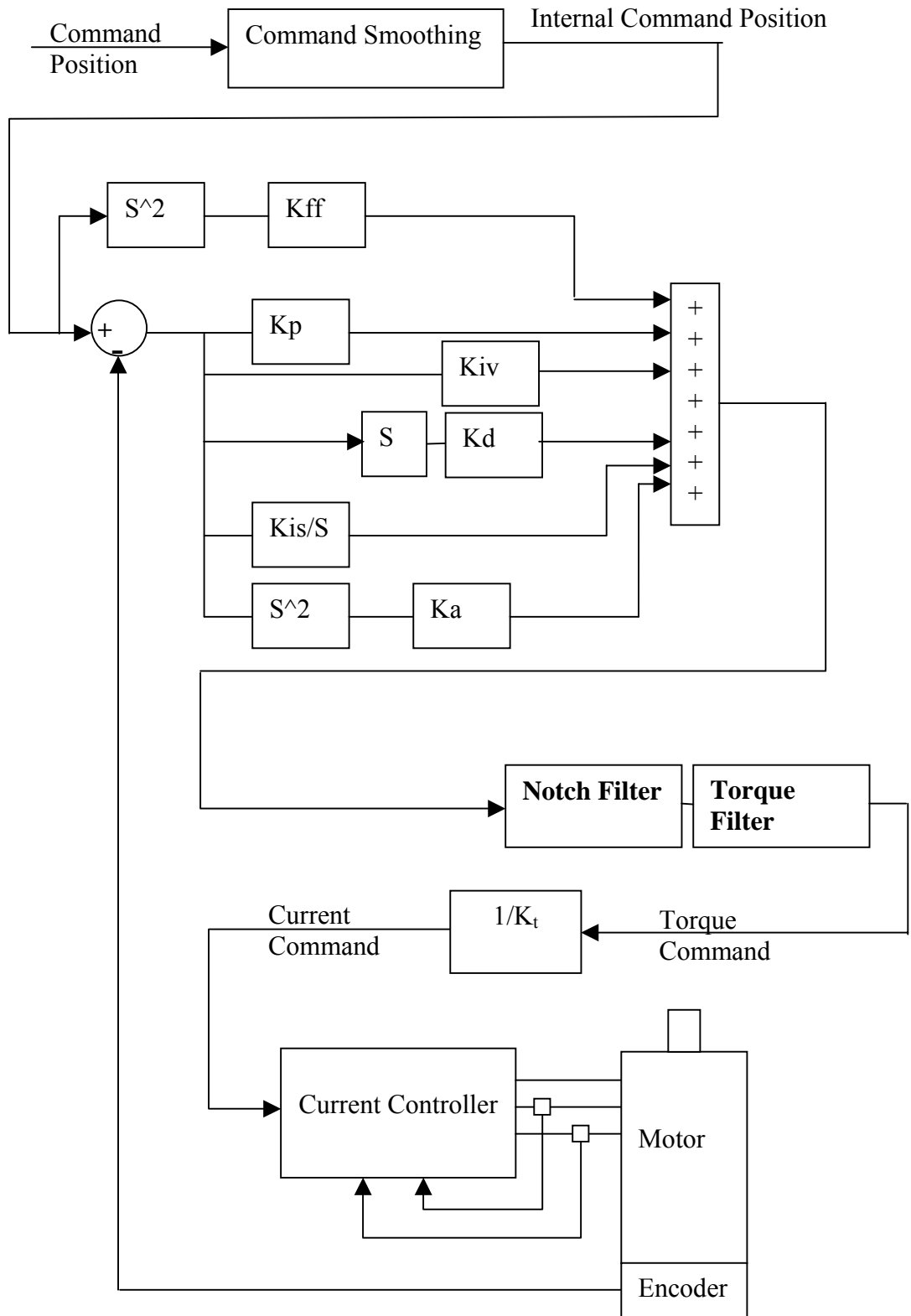

6.3.3. NCT Gain Parameters

The following are the main parameters of NCT servo control:

Kd	Pn1AC	Differential gain
Kp	Pn1AA	Proportional gain
Kiv	Pn1AB	Additional proportional gain
Kis	Pn1A9	Integral feedback gain
Ka	Pn1AD	Acceleration gain

These parameters should be tuned in the order of the list above.

- **Kd (Pn1AC) range 0-2000 [Hz] default 30:**

This parameter is equivalent to a velocity loop gain. It produces damping of the movement.

The higher this parameter can be increased, the better the final tuning will be. However, the increase is limited by the flexibility of the mechanical system driven.

A too high value of Kd will cause high frequency oscillations of the system.

For tuning, raise the value of that parameter progressively until oscillations are observed or acoustic noise is heard. Then reduce back to a safe value (around 10 to 20%, depending on the system).

- **Kp (Pn1AA) range 0-500 [Hz] default 40:**

This parameter sets the position loop gain.

For tight control, increase it until overshoot or oscillations are observed. Then reduce back and set according to the level of overshoot/undershoot desired.

Value $30 \cdot (J_{total}/J_{motor})^{0.5}$ can be used as a reference value.

- **Kiv (Pn1AB) range 0-500 [Hz], default 30:**

This parameter is an additional position loop gain. Using proprietary NCT technique, this gain increases stiffness and reduces the position error during the trajectory following, without causing overshoot or oscillations.

Proceed as for Kp for tuning. Normally, the range of this parameter is

$$K_p/2 < K_{iv} < K_p$$

- **Kis (Pn1A9) range 0-500 [Hz] default 40:**

This parameter is the equivalent of the integral loop gain. It cancels the position error at stop and minimizes it during movement.

As for previous gains, increase until vibrations occur, then reduce back to a safe value.

The oscillations observed when a too high Kis is used are usually at lower frequency.

- **Ka (Pn1AD) range 0-500 [%], default 0. Filter Pn1AE range 0-2500 [0.01ms] default 300:**

This parameter is the acceleration gain. It can be used when there is a high-resolution encoder. In most cases, a 0 value is used, but in some cases it can improve the control quality.

- **Kff (Pn1AF) range 0-200 [%] default 0. This parameter is used only in a serial command (Pn000.1=D):**

This parameter is the feed forward of command acceleration into the command torque. Tune this parameter after you finished tuning the previous parameters. It reduces position error during movement and during acceleration and deceleration phase.

6.3.4. OCA - Oscillation Canceling Algorithm

Version	XtraDrive Version	XtraWare Version
The following description relates to:	2.8	2.5.3

General Description

OCA is used to dynamically eliminate vibrations during motion. The frequency of Speed Error vibrations (within the range of 500 – 2000 Hz) detected by the driver are eliminated on the fly, allowing increase of gain and reduction of noise.

Recommendations:

- Since autotuning takes the OCA into account, it is advisable to run autotuning in the same OCA mode (active or non-active) as that in which the system works.
- Use a very low Torque Filter when the OCA is active.
- It is possible to activate OCA together with the notch filter.
- In cases of stiff machines where coupling with the load is very strong (no backlash, no coupling or very stiff coupling), better performance can be obtained without OCA.

Setting

Parameter	Name	Setting	Description	Default
Pn2D4	Oscillation Canceling Mode	0	OCA is not active	1
		1	OCA is active	

6.3.5. Additional Parameters Tuning

After having set the default value for a given load, additional tuning may be done. Typically, the following parameters can be further tuned:

Torque Filters	Pn1A2-Pn1A5	To prevent vibrations with flexible coupling and poor damping.
Command Smoothing	Pn216	To smooth movement in case of flexible system.
Tightness	Pn1A0	To increase/decrease gain.
Variable gain	Pn1B5-Pn1B9	To increase gain during movement.
Flexible system	Pn1BB-Pn1BD	To compensate the overshoot and smooth the movement.

6.3.6. Filters

Filters are used to avoid vibrations, thus allowing a higher value of loop gain.

Filters should be set in an iterative way, where each time a new filter value is tried; the velocity loop gain is re-tuned. Typically, the final value selected for the filter will be the one that allows the highest Kd.

- **Kd Filter (Pn1A2), Range 30-3200[0.01ms], Default 40:**

This parameter sets a low pass filter on differential gain, a good starting value is about Pn103/10, where the minimum value is 30 [0.01ms]. A low value for this parameter will make noise in high frequency.

Typically, this parameter will have to be increased if load coupling is flexible, and damping is poor.

- **Torque Filter (Pn1A4), Range 0-2500[0.01ms], Default 20:**

This parameter sets a low pass filter on torque command. A good starting value is about Pn103/10, if you use notch filter (Pn408.0=1) (see 6.1.6). It is better not to use torque filter or to use a small value.

Typically, this parameter will have to be increased if load coupling is flexible, and damping is poor.

This parameter should be set to a value only slightly higher than the value at which oscillations disappear. Using an unnecessary high value will degrade the control quality. Typically, chose the value that allows the highest value setting of Kd.

- **Second Order Torque Filter (Pn1A5), Range 0-1000 [0.1%], Default 0:**

This parameter is a part of the second order torque filter. It has good influence in many cases, even if the first order torque filter is not active.

After tuning Pn1A4, raise this parameter progressively until vibrations occur. In many systems, values for this parameter will be in the 500—700 (0.1%).

- **Command Smoothing (Pn216), Range 0-65536 [0.1ms], Default 0: (See 6.1.2)**

In case of a flexible system, if command acceleration is not applied progressively, the system will oscillate around the command position after every discontinuity of the command acceleration (even if the oscillation is not seen). The command-smoothing smoothes the command acceleration to avoid these oscillations.

Using a command filter will delay the arrival of the command to the final target position. The value of this filter should be set higher than the period of self-oscillations, but not too high to keep good settling time.

6.3.7. Flexible System Parameters

- **K_{ff}Spring (Pn1BB) range 10-2000 [Hz] default 2000:**

This parameter compensates the position error during the acceleration and deceleration phase and the overshoot observed when stopping at the end of a deceleration phase. Typically, this overshoot is caused by the elasticity of the system; a wind up occurs during the deceleration phase and relaxes after stop. The K_{ff}Spring parameter compensates for that wind up.

The frequency of this parameter relates to the self-oscillation frequency of the system. It can be adjusted to avoid overshoot and minimize settling time.

Default value is 2000 Hertz. This value is well beyond the frequency response of usual systems, so that it has no influence.

To adjust, decrease this value progressively, while monitoring the position error, until overshoot is canceled or position error in the acceleration and deceleration phase are minimized.

- **K_{fb}Spring (Pn1BD) range 10-2000 [Hz] default 2000:**

This parameter compensates the vibrations of the motor, it smoothes the control in case of a flexible system. Usually it should be tuned to the low resonance of the system.

You can tune this parameter by progressively decreasing its value until vibrations occur. Then use a higher value for setting (~20%).

6.3.8. Gain Factor

- **Tightness (Pn1A0), Range 0-500[%], Default 60:**

This parameter changes the frequencies of feedback parameter linearly, keeping their relative ratio, so that system rigidity can be changed without getting unstable. A good starting value is 60[%].

After setting the default values for load, one can increase or decrease the stiffness of the servo control by changing this parameter.

This can be done while monitoring the position error during the movement and thus choosing the optimal value for the system application.

- **Maximum of Variable Gain MAXKG (Pn1B5), Range 100-1000 [%], Default 160:**

This parameter sets the maximum variable gain during movement. To cancel variable gain, set this parameter to 100[%]. To use variable gain, increase it, usually 160-200% is enough. If one sets this parameter to 200%, it means that gain can be raised to 200% of the written parameter value during movement.

6.3.9. Integral Clear Parameters

- **Integral Clear Mode (Pn1A7, digit 0):**

This parameter activates a special treatment of integral at the end of a decelerating ramp.

When using a command having a trapezoid speed profile, at the end of the deceleration there is a discontinuity of acceleration; at this point, deceleration abruptly changes its value from maximum to zero. Normally, this would create an overshoot of the system. This discontinuity is compensated by addition of a calculated value to the integral at that particular time, thus avoiding the overshoot.

Software detects the end of a command deceleration phase, calculates the compensating value and adds it to the integral.

- In case of point-to-point movements with trapezoid profile: set to 1.
- In case of very smoothed command acceleration: reset to zero.

- **Integral clear timing (Pn1BF), Range 1-15, Default 3:**

This parameter defines the timing of a clear integral. Reducing this parameter will delay the clear integral, and increasing will speed up the clear integral.

- **Integral Offset Averaging Time (Pn1C0), Range 0-25[ms], Default 0:**

This parameter defines the time needed to calculate a steady torque at stop. This value is used to execute a more precise integral modification at the end of the movement.

In horizontal systems, this parameter should be zero.

This parameter changes the frequencies of feedback parameter linearly, keeping their relative ratio, so that system rigidity can be changed without getting unstable. A good starting value is 60[%].

After setting the default values for load, one can increase or decrease the stiffness of the servo control by changing this parameter.

This can be done while monitoring the position error during the movement and thus choosing the optimal value for the system application.

- **Maximum of Variable Gain MAXKG (Pn1B5), Range 100-1000 [%], Default 160:**

This parameter sets the maximum variable gain during movement. To cancel variable gain, set this parameter to 100[%]. To use variable gain, increase it, usually 160-200% is enough. If one sets this parameter to 200%, it means that gain can be raised to 200% of the written parameter value during movement.

6.3.9. Integral Clear Parameters

- **Integral Clear Mode (Pn1A7, digit 0):**

This parameter activates a special treatment of integral at the end of a decelerating ramp.

When using a command having a trapezoid speed profile, at the end of the deceleration there is a discontinuity of acceleration; at this point, deceleration abruptly changes its value from maximum to zero. Normally, this would create an overshoot of the system. This discontinuity is compensated by addition of a calculated value to the integral at that particular time, thus avoiding the overshoot.

Software detects the end of a command deceleration phase, calculates the compensating value and adds it to the integral.

- In case of point-to-point movements with trapezoid profile: set to 1.
- In case of very smoothed command acceleration: reset to zero.

- **Integral clear timing (Pn1BF), Range 1-15, Default 3:**

This parameter defines the timing of a clear integral. Reducing this parameter will delay the clear integral, and increasing will speed up the clear integral.

- **Integral Offset Averaging Time (Pn1C0), Range 0-25[ms], Default 0:**

This parameter defines the time needed to calculate a steady torque at stop. This value is used to execute a more precise integral modification at the end of the movement.

In horizontal systems, this parameter should be zero.

6.3.10. Tuning Procedure for Position Control Parameters

■ System Requirements

Use any command input to the XtraDrive, and watch the performance of control (see analog output).

It is recommended to use commands that include a constant speed section (plateau of trapeze for example). Potential vibrations of the system may not be observed during the tuning procedure if no constant speed section is used.

Tuning is done while checking the items of the control quality required for the specific application. These items can vary, depending on the application.

Typically, items of control quality are:

- **Smoothness:** Can be estimated by the behavior of the position error with time. If the position error changes sign rapidly and/or with great amplitude, then smoothness is poor.
- **Settling time:** Can be measured as the time it takes to reach a zero position error after the command speed reaches zero.
- **Stiffness:** Can be measured by monitoring the position error amplitude resulting from a perturbation.

This perturbation can be an abrupt change in command acceleration, for example by using a triangle shape for the speed profile of a command, or a physical impact applied on shaft or load.

- **Overshoot:** Can be measured by the sign of position error after movement stops.

■ The Tuning Steps

During each tuning step, the quality of control is monitored with the user-required movements according to the user's criteria.

1. Use Fast Tuning in order to load a starting set of parameters for the given load.
2. Tune the following parameters:
 - a) Set the **Torque Filter (Pn1A4)** to zero.
 - b) Raise **K_d (Pn1AC)** to the maximum possible value for a smooth movement, then decrease that value by about 20%.
 - c) Increase the torque filter and repeat Step b. Continue increasing the torque filter until the maximum value of K_d is obtained.
 - d) Raise **K_p (Pn1AA)** to the maximum value that gives a smooth movement, then decrease that value by about 20%.
 - e) Raise **K_{is} (Pn1A9)** till there is no overshoot.

- f) Increase the **Second Order** torque filter (**Pn1A5**) to obtain smoothed movement, very helpful in flexible systems. You can increase it till 60 to 70 percentages.
 - g) If necessary, repeat sub-steps **b**) to **d**) until an optimal value is obtained.
 - h) You can try to increase **Ka** (**Pn1AD**), this will sometimes improve results. You must have some filter on acceleration feedback (**Pn1AE**).
3. Tune flexible system parameters.
- a) **KffSpring (Pn1BB)**. This parameter may be used to suppress overshoot, to reduce it progressively, or to cancel overshoot.
 - b) **KfbSpring (Pn1BD)**. This parameter may be used to suppress oscillations in a flexible system. Default value is 2000Hz. Decrease progressively, or try values close to the suspected low self-oscillation frequencies.
4. Advanced parameter:
- Integral Offset Averaging Time (Pn1C0)**. If this parameter is set (>0), then each time the system is stopped (no command input), an average value of the steady torque is calculated. This value is then used as an adaptive offset for the torque command. The averaging time for this offset is set by the value of Pn1C0. Increase it if you have some force on the motor in a steady state, like gravity.

6.4. Analog Monitor

The analog monitor can be used to observe a variety of analog voltage signals. Analog monitor signals must be observed through the CN5 connector using the Yaskawa P/N DE9404559 cable.

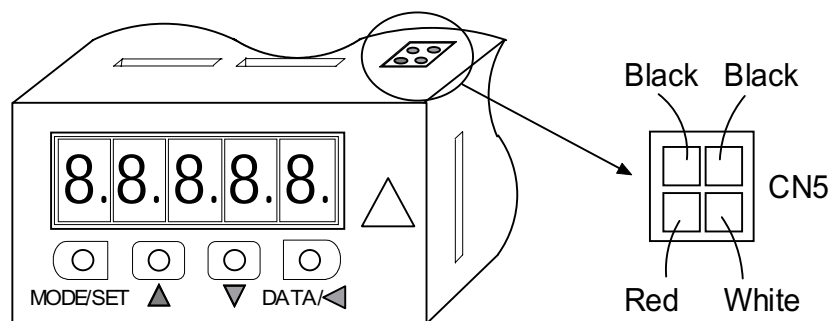

Cable Color	Signal Name	Description
White	Analog monitor 1	Torque reference: 1V/100% rated torque
Red	Analog monitor 2	Motor speed: 1V/1000 rpm
Black (two wires)	GND (0V)	—

Analog monitor signals can be selected with parameters:

Pn003.0 (if Pn006.1=0) and Pn003.1 (if Pn007.1=0) or

Pn006.0 (if Pn006.1=1) and Pn007.0 (if Pn007.1=1).

Parameter	Signal	Setting	Description
Pn003.0	Analog Monitor 1	Default Setting: 2	Speed/Torque Control, Position Control
Pn003.1	Analog Monitor 2	Default Setting: 0	Speed/Torque Control, Position Control

The following monitor signals can be observed.

Settings in Pn003.0 and Pn003.1	Description	
	Monitor signal	Observation gain
0	Motor speed	1V / 1000rpm
1	Speed reference	1V / 1000rpm
2	Torque reference	1V / 100% rated torque
3	Position error	0.05V / 1 reference unit
4	Position error	0.05V / 100 reference unit
5	Reference pulse frequency (converted to rpm)	1 V / 1000rpm
6	Motor speed	1 V / 250rpm
7	Motor speed	1 V / 125rpm

Note: 1. In the case of torque or speed control mode, the position error monitor signal has no meaning.

2. The output voltage range of the analog monitor is $\pm 8V$ maximum. The polarity of the output voltage will be changed if $\pm 8V$ is exceeded.

Settings in Pn006.0 and Pn007.0	Description	
	Monitor signal	Observation gain
0	Servo position error	1V / 10 Encoder Counts
1	Servo position error	1V / 5 User Units
2	Target speed	1V / 500 rpm.
3	Smoothed target speed	1V / 500 rpm.
4	Torque	10V / Max. Torque
5	Motor speed	1V / 500 rpm.
6	Target acceleration	10V / Max. Acceleration

Note: If the monitored signal does not fit the oscilloscope, it can be resized by the magnification parameter Pn006.2 for channel 1 and by Pn007.2 for channel 2. Refer to the following table for details:

Settings in Pn006.2 and Pn007.2	Output Magnification
0	x1
1	x10
2	x100
3	$x\frac{1}{10}$
4	$x\frac{1}{100}$

7. Using the Panel Operator

This chapter describes the basic operation of the digital operator and the features it offers. All parameter settings and motor operations can be executed by simple, convenient operations. Operate the digital operator as you read through this chapter.

7.1.	Basic Operation.....	7-2
7.1.1.	Panel Operator	7-2
7.1.2.	Resetting Servo Alarms	7-3
7.1.3.	Basic Mode Selection	7-3
7.1.4.	Status Display Mode	7-4
7.1.5.	Operation in Parameter Setting Mode.....	7-6
7.1.6.	Operation in Monitor Mode	7-11
7.2.	Applied Operation.....	7-16
7.2.1.	Operation in Alarm Traceback Mode	7-17
7.2.2.	JOG Operation	7-18
7.2.3.	Automatic Adjustment of the Speed and Torque Reference Offset..	7-20
7.2.4.	Manual Adjustment of the Speed and Torque Reference Offset	7-22
7.2.5.	Clearing Alarm Traceback Data	7-25
7.2.6.	Checking the Motor Model.....	7-26
7.2.7.	Checking the Software Version	7-27
7.2.8.	Origin Search Model.....	7-28
7.2.9.	Initializing Parameter Settings.....	7-30
7.2.10.	Manual Zero Adjustment and Gain Adjustment of Analog Monitor Output	7-31
7.2.11.	Adjusting the Motor Current Detection Offset	7-34
7.2.12.	Write Protected Setting	7-36
7.2.13.	Clearing the Option Unit Detection Alarm	7-37

7.1. Basic Operation

This section provides information on the basic operation of the built-in digital operator for setting operating conditions.

7.1.1. Panel Operator

A built-in operator incorporating a panel indicator and switches is located on the front panel of the servo amplifier. This type of digital operator is also called a panel operator.

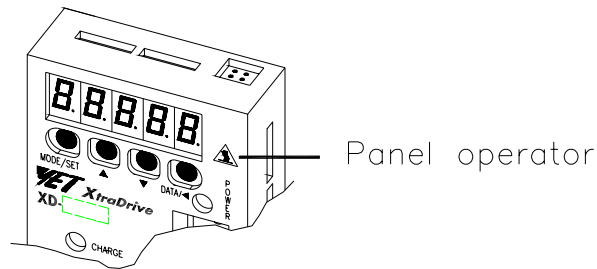

■ Display Messages

The following messages appear when using the Panel Operator.

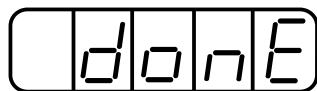

.....When a function is executed.

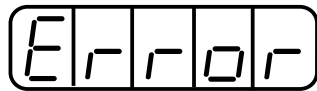

.....When an operation has failed.

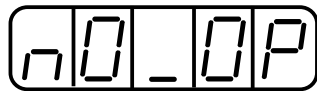

.....When an operation is not executed.

Key	Name	Function
	Up Arrow	<ul style="list-style-type: none"> Press this key to set parameters or display the set values of parameters. Press the Up Arrow key to increase the set value. Press the Down Arrow key to decrease the set value. Press the Up and Down Arrow keys together to reset a servo alarm.
	Down Arrow	
	MODE/SET	Press this key to select the Status Indicator mode, Auxiliary Function mode, Parameter Setting mode, or Monitor mode.
	DATA/SHIFT	<ul style="list-style-type: none"> Press this key to set each parameter or display the set value of each parameter. This key is used for selecting the editing (flashing) digit or data setting.

7.1.2. Resetting Servo Alarms

Servo alarms can be reset using the digital operator.

■ Using the Built-in Panel Operator

Press the **Up Arrow ▲** AND **Down Arrow ▼** keys together in Status Display mode.

The alarm can be reset with CN1-44 or /ALM-RST signal input. Refer to 5.5.1 *Using Servo Alarm and Alarm Code Outputs*.

The servo alarm will be reset if the control power supply is turned OFF.

IMPORTANT

- If an alarm is ON, reset the alarm after eliminating the cause of the alarm first. Refer to 9.2 *Troubleshooting*.

7.1.3. Basic Mode Selection

Basic mode selection of the digital operator is used for indicating the status of the servo amplifier in operation and setting a variety of parameters and operation references.

Basic modes are Status Display, Auxiliary Function, Parameter Setting, and Monitor modes. As shown below, the mode is selected in the specified order by pressing the key.

Press the MODE/SET key for basic mode changes:

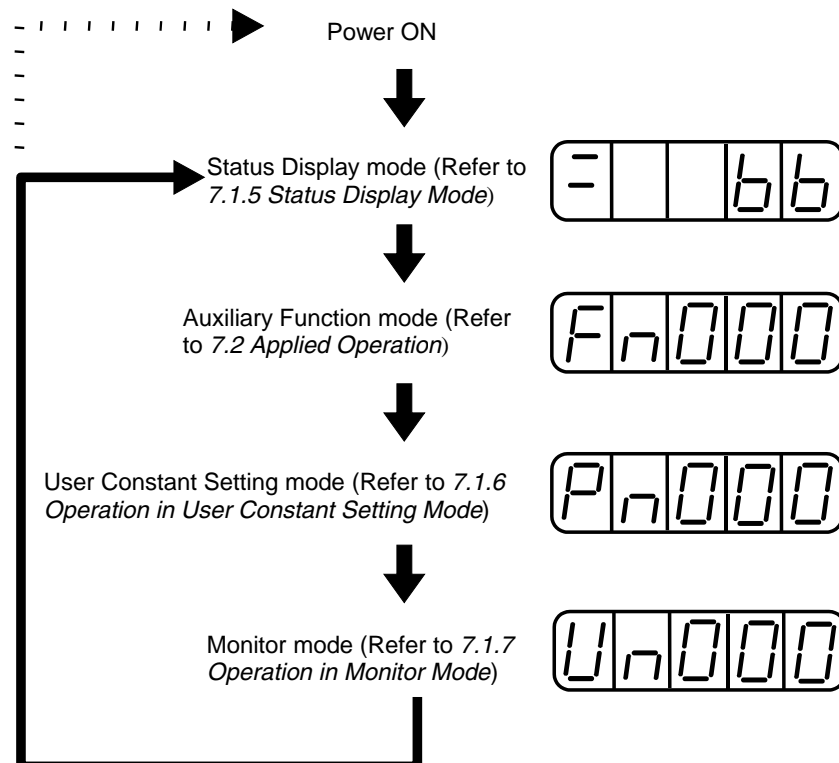

7.1.4. Status Display Mode

In Status Display mode, bit data and codes are displayed to indicate the status of the servo amplifier.

■ Selecting Status Display Mode

The digital operator goes into Status Display mode when the digital operator is turned ON.

■ Data in Status Display Mode

Screen contents in Status Display mode are different for Speed, Torque, and Position Control modes.

Speed and Torque Control Mode

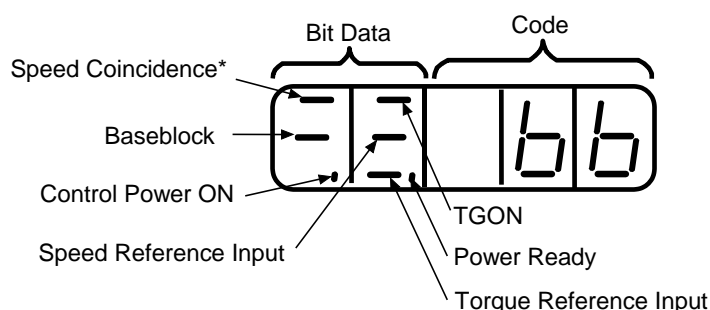

* This indicator is always lit when the XtraDrive is in Torque Control mode

The following tables list and explain the meanings of bit data and code displays in Speed and Torque Control modes.

Bit Data and Meanings in Speed and Torque Control Mode	
Bit Data	Meaning
Control Power ON	Lit when servo amplifier control power is ON.
Baseblock	Lit for baseblock. Not lit when servo is ON.
Speed Coincidence	Lit when the difference between motor speed and reference speed is the same as or less than the value set in Pn503. (The default value set in Pn503 is 10rpm).
/TGON	Lit if motor speed exceeds preset value Preset value: Set in Pn502. (Default setting is 20rpm).
Speed Reference Input	Lit if input speed reference exceeds preset value. Specified value: Set in Pn502. (Default setting is 20rpm)
Torque Reference Input	Lit if input torque reference exceeds preset value. Preset value: 10% rated torque is default setting
Power Ready	Lit when main power supply circuit is operating at normal level. Not lit when power is OFF.



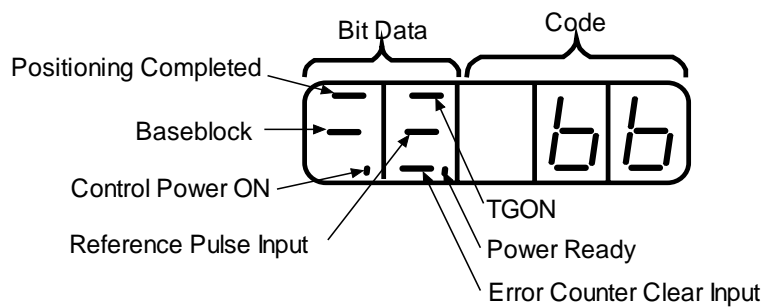

Codes and Meanings in Speed and Torque Control Mode	
Code	Meaning
	Baseblock Servo OFF (motor power OFF)
	Run Servo ON (motor power ON)
	Forward Run Prohibited CN1-42 (P-OT) is OFF. Refer to 5.1.2 <i>Setting the Overtravel Limit Function</i> .
	Reverse Run Prohibited CN1-43 (N-OT) is OFF. Refer to 5.1.2 <i>Setting the Overtravel Limit Function</i> .
	Alarm Status
	Displays the alarm number. Refer to 9.2 <i>Troubleshooting</i> .

Position Control Mode

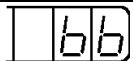
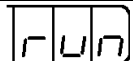

The following tables list and explain the meanings of bit data and code displays in Position Control mode.

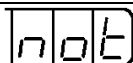
Bit Data and Meanings in Position Control Mode	
Bit Data	Meaning
Control Power ON	Lit when servo amplifier control power is ON.
Baseblock	Lit for baseblock. Not lit when servo is ON.
Positioning Completed	Lit if error between position reference and actual motor position is below preset value. Preset value: Set in PN500. (Default setting is 7 pulses).
/TGON	Lit if motor speed exceeds preset value. Preset value: Set in Pn502. (Default setting is 20rpm).
Reference Pulse Input	Lit if reference pulse is input.
Error Counter Clear Input	Lit when error counter clear signal is input.
Power Ready	Lit when the main power supply circuit is operating at normal level. Not lit when power is OFF.

Codes and Meanings in Position Control Mode	
Code	Meaning
	Baseblock Servo OFF (motor power OFF)
	Run Servo ON (motor power ON)
	Forward Run Prohibited CN1-42 (P-OT) is OFF. Refer to 5.1.2 <i>Setting the Overtravel Limit Function</i> .
	Reverse Run Prohibited CN1-43 (N-OT) is OFF. Refer to 5.1.2 <i>Setting the Overtravel Limit Function</i> .
	Alarm Status
	Displays the alarm number. Refer to 9.2 <i>Troubleshooting</i> .

7.1.5. Operation in Parameter Setting Mode

Functions can be selected or adjusted by setting parameters. There are two types of parameters that can be set. One type requires value setting and the other requires function selection. These two types use different setting methods.

- With value setting, a parameter is set to a value within the specified range of the parameter.
- With function selection, functions allocated to each digit of the seven-segment LED panel indicator (five digits) can be selected.

Refer to *Appendix D List of Parameters*.

■ Changing Parameter Value Settings

Parameter value settings can be used to change parameter data. Check the permitted range of the parameters in *Appendix D List of Parameters*, before changing the data.

The example below shows how to change parameter Pn507 from 100 to 85.

Example

1. Press the **MODE/SET** key to select the Parameter Setting mode.



2. Press the **Left** or **Right Arrow** keys to select the digit and the **Up Arrow** or **Down Arrow** keys to set the parameter value. (Pn507 is selected in this example.)

3. Press the **DATA/SHIFT** key for a minimum of one second to display the current data for the parameter selected in step 2.

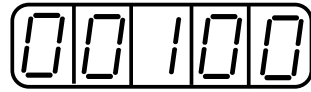

4. Press the **Up Arrow** or **Down Arrow** key to change the value as desired to “00085”.
5. Press the **DATA/SHIFT** key for a minimum of one second to save the data. The display will flash.

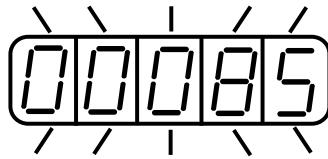

6. Press the **DATA/SHIFT** key once more for a minimum of one second to display the parameter number again.

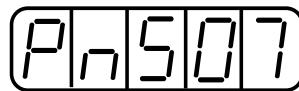

This has changed the setting of the parameter Pn507 from 100 to 85.

Repeat steps 2 to 6 to change the setting again.

Note: Parameter numbers that are not defined are skipped during operator operations.

IMPORTANT

- Press the **DATA/SHIFT** key for a maximum of one second to shift to a higher (left) digit.

■ Function Selection Parameters

Function Selection Parameter Types

The following table shows the parameters for selecting servo amplifier functions.

Category	Parameter Number	Name	Default Setting	Important Note
Function Selection Parameters	Pn000	Function Selection Basic Switches	00D0	(See 1)
	Pn001	Function Selection Application Switches 1	0000	(See 1)
	Pn002	Function Selection Application Switches 2	0000	(See 1)
	Pn003	Function Selection Application Switches 3	0002	—
Gain-related Parameters	Pn10B	Gain-related Application Switches	0000	(See 2)
	Pn110	Online Autotuning Switches	0010	(See 2)
Position Control related Parameter	Pn200	Position Control Reference Selection Switches	0000	(See 1)
Sequence-related Parameters	Pn50A	Input Signal Selections 1	2100	(See 1)
	Pn50B	Input Signal Selections 2	6543	(See 1)
	Pn50C	Input Signal Selections 3	8888	(See 1)
	Pn50D	Input Signal Selections 4	8888	(See 1)
	Pn50E	Output Signal Selections 1	3211	(See 1)
	Pn50F	Output Signal Selections 2	0000	(See 1)
	Pn510	Output Signal Selections 3	0000	(See 1)

IMPORTANT

1. After changing these parameters, turn OFF the main circuit and control power supplies and then turn them ON again to enable the new settings.
2. Changing bits Pn10B.1 and Pn110.0 require the same sequence described in note 1 (above).

Parameter settings are displayed in two patterns as shown below.

Display Application	Display	Format
Function selection		Hexadecimal display for each digit
Parameter setting		Decimal display in five digits

Since each digit in the function selection parameters has its own meaning, the value can only be changed for each individual digit. Each digit can only display a value within its own permitted range.

Display Definition for Function Selection Parameters

Each digit of the function selection parameters has a unique meaning.

For example, the rightmost digit of parameter Pn000 is expressed as “Pn000.0”.

- Each digit of the function selection parameters is defined as shown below. The parameter displayed below shows how the digits in the display are assigned.

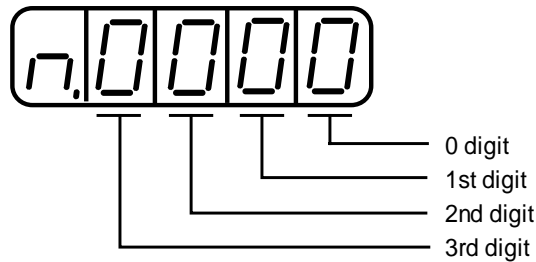

Distribution of Parameter Digits	
Designation	Meaning
Pn000.0	Indicates the value entered at the 0 digit of parameter Pn000.
Pn000.1	Indicates the value entered at the 1 digit of parameter Pn000.
Pn000.2	Indicates the value entered at the 2 digit of parameter Pn000.
Pn000.3	Indicates the value entered at the 3 digit of parameter Pn000.

■ Changing Function Selection Parameter Settings

1. Press the **MODE/SET** key to select the Parameter Setting mode.



2. Press the **Up Arrow** or **Down Arrow** key to select the parameter number to be set. (Pn000 is selected in this example.)
3. Press the **DATA/SHIFT** key for a minimum of one second to display the current data for the selected parameter.

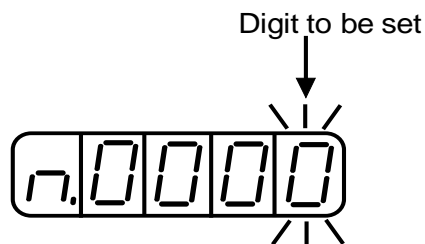

4. Press the **DATA/SHIFT** key to select the digit to be set.

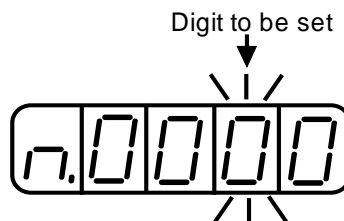

5. Press the **Up Arrow** or **Down Arrow** key to select the value defined as a function setting for the selected digit.

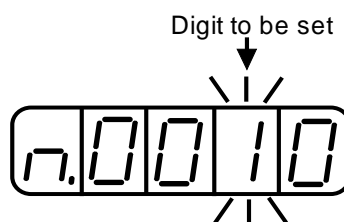

Repeat the steps 4 and 5 above for changing the data as required.

6. Press the **DATA/SHIFT** key for a minimum of one second to save the data. The display will flash.

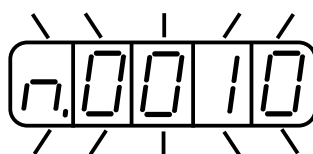

7. Press the **DATA/SHIFT** key once more for a minimum of one second to return to the parameter number display.

This has changed the 1 digit of parameter Pn000 to “1”.

7.1.6. Operation in Monitor Mode

The Monitor mode can be used for monitoring the reference values, I/O signal status, and servo amplifier internal status.

The Monitor mode can be set during motor operation.

■ Using the Monitor Mode

The example below shows how to display 1500; the contents of monitor number Un000 when the servomotor rotates at 1500rpm.

1. Press the **MODE/SET** key to select the Monitor mode.

2. Press the **Up Arrow** or **Down Arrow** key to select the monitor number to be displayed.
3. Press the **DATA/SHIFT** key for a minimum of one second to display the monitor number selected in step 2 above.

4. Press the **DATA/SHIFT** key once more for a minimum of one second to return to the monitor number display.

This has changed the 1 digit of parameter Pn000 to “1”.

This completes the example procedure for displaying 1500; the contents of monitor number Un000.

■ Contents of Monitor Display

The following table shows contents of the monitor display.

Monitor Number	Monitor Display	Unit	Comments
Un000	Actual motor speed	rpm	—
Un001	Input speed reference	rpm	(See note 3 below)
Un002	Internal torque reference	%	Value for rated torque
Un003	Rotation angle 1	pulses	Number of pulses from the origin
Un004	Rotation angle 2	degree	Angle (electrical angle) from the origin
Un005	Input signal monitor	—	(See note 1 below)
Un006	Output signal monitor	—	(See note 1 below)
Un007	Input reference pulse speed	rpm	(See note 4 below)
Un008	Error counter value	reference unit	Positional error (See note 4 below)
Un009	Accumulated load rate	%	Value for the rated torque as 100% Displays effective torque in 10s cycle.
Un00A	Regenerative load rate	%	Value for the processable regenerative power as 100% Displays regenerative power consumption in 10s cycle.
Un00B	Power consumed by DB resistance	%	Value for the processable power when dynamic brake is applied as 100% Displays DB power consumption in 10s cycle.
Un00C	Input reference pulse counter	—	In hexadecimal (See notes 2 and 4 below)
Un00D	Feedback pulse counter	—	In hexadecimal

- Note:**
1. Refer to *Sequence I/O Signal Monitor Display* on the next page.
 2. Refer to *Reference Pulse/Feedback Pulse Counter Monitor Display* on page 7 - 22.
 3. Displayed only in Speed Control mode.
 4. Displayed only in Position Control mode.

■ **Sequence I/O Signal Monitor Display**

The following section describes the monitor display for sequence I/O signals.

Input Signal Monitor Display

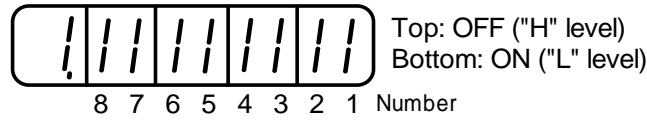

LED Number	Input Terminal Name	Default Setting
1	SI0 (CN1-40)	/S-ON
2	SI1 (CN1-41)	/P-CON
3	SI2 (CN1-42)	P-OT
4	SI3 (CN1-43)	N-OT
5	SI4 (CN1-44)	/ALM-RST
6	SI5 (CN1-45)	/P-CL
7	SI6 (CN1-46)	/N-CL
8	(CN1-4)	SEN

Note: Refer to 5.3.3 *Input Circuit Signal Allocation* for details on input terminals.

Input signals are allocated as shown above and displayed on the panel of the servo amplifier or the digital operator. They are indicated by the ON/OFF status of the vertical parts of the seven-segment displays located in top and bottom rows. (The horizontal segments are not used here). These vertical segments turn ON or OFF relative to the state of the corresponding input signals (ON for “L” level and OFF for “H” level).

Examples

- When /S-ON signal is ON (Servo ON at “L” signal)

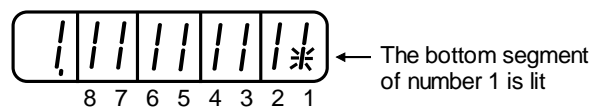

- When /S-ON signal is OFF

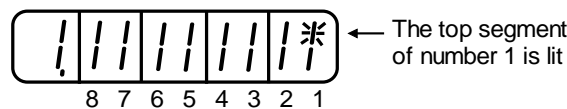

- When P-OT signal operates (Operates at “H” signal)

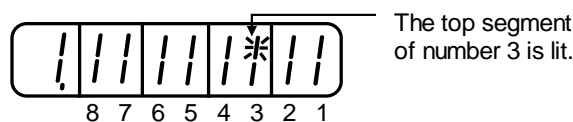

Output Signal Monitor Display

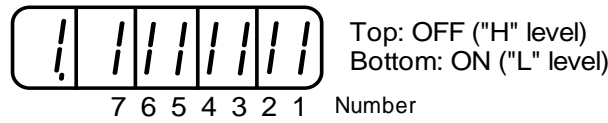

LED Number	Output Terminal Name	Default Setting
1	(CN1-31, -32)	ALM
2	SO1 (CN1-25, -26)	/COIN or /V-CMP
3	SO2 (CN1-27, -28)	/TGON
4	SO3 (CN1-29, -30)	/S-RDY
5	(CN1-37)	AL01
6	(CN1-38)	AL02
7	(CN1-39)	AL03

Note: Refer to 5.3.4 *Output Circuit Signal Allocation* for details on output terminals.

Output signals are allocated as shown above and displayed on the panel of the servo amplifier or the digital operator. They are indicated by the ON/OFF status of the vertical parts of seven-segment displays located in top and bottom rows. (The horizontal segments are not used here). These vertical segments turn ON or OFF relative to the state of the corresponding output signals (ON for "L" level and OFF for "H" level).

Example

- When ALM signal operates (alarm at "H")

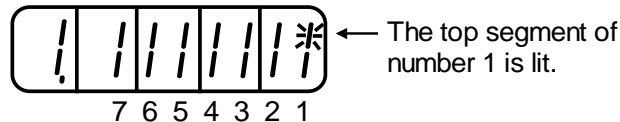

■ Reference Pulse/Feedback Pulse Counter Monitor Display

The monitor display of the reference pulse counter and feedback pulse counter is expressed in 32-bit hexadecimal.

The display procedure is as follows:

1. Press the **MODE/SET** key to select the Monitor mode.
2. Press the **Up Arrow** AND **Down Arrow** keys to select “Un00C” or “Un00D”.
3. Press the **DATA/SHIFT** key for a minimum of one second to display the data for the monitor number selected in the step above.

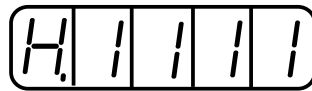

4. Press the **Up Arrow** or **Down Arrow** key to alternately display the leftmost 16-bit data and rightmost 16-bit data.



Leftmost 16-bit Data

Rightmost 16-bit Data

5. Press both the **Up Arrow** AND **Down Arrow** keys simultaneously to clear the 32-bit counter data.
6. Press the **DATA/SHIFT** key once more for at least one second to return to the monitor number display.

7.2. Applied Operation

This section describes how to apply basic operations, using the digital operator, to run and adjust the motor. Read the description of the basic operations in *7.1 Basic Functions* before proceeding to this section.

Parameters for applied operation can be set in the Auxiliary Function mode. The following table shows the parameters in the Auxiliary Function mode.

Parameter Number	Function	Comments
Fn000	Alarm traceback data display	—
Fn001	Rigidity setting during online auto-tuning	(See note).
Fn002	JOG mode operation	—
Fn003	Zero-point search mode	
Fn004	(Reserved parameter)	
Fn005	Parameter settings initialization	
Fn006	Alarm traceback data clear	(See note).
Fn007	Writing to EEPROM the inertia ratio data obtained from online auto-tuning	
Fn008	Absolute encoder multi-turn reset and encoder alarm reset.	
Fn009	Automatic tuning of analog (speed, torque) reference offset	
Fn00A	Manual adjustment of speed reference offset	
Fn00B	Manual adjustment of torque reference offset	
Fn00C	Manual zero-adjustment of analog monitor output	
Fn00D	Manual gain-adjustment of analog monitor output	
Fn00E	Automatic offset-adjustment of motor current detection signal	
Fn00F	Manual offset-adjustment of motor current detection signal	
Fn010	Password setting (protects from parameter changes)	—
Fn011	Motor models display	
Fn012	Software version display	
Fn013	Change Multi-Turn Limit Setting Value when a Multi-Turn Limit Disagreement Alarm occurs	(See note).
Fn014	Clear of option unit detection results	(See note).

Note: These parameters and those indicated as Pn□□□ are displayed as shown below if their write protection is set (Fn010). Under these circumstances, these parameters cannot be changed. An “Error” message is flashing while trying to change.

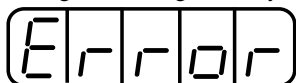

flashing for one second.

7.2.1. Operation in Alarm Traceback Mode

The Alarm Traceback mode can display up to ten alarms that have occurred, thus making it possible to check what kind of alarms have been generated.

Alarm traceback data is not cleared on alarm reset or when the servo amplifier power is turned OFF.

The data can be cleared using the special “clear alarm traceback mode.” Refer to 7.2.5 *Clearing Alarm Traceback Data* for details.

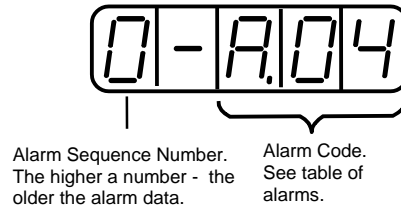

■ Checking Alarms

Follow the procedure below to determine which alarms have been generated.

1. Press the **MODE/SET** key to select “Displaying alarm traceback data (Fn000)” in the Auxiliary Function mode.



2. Press the **DATA/SHIFT** key for a minimum of one second to display the alarm traceback data.
3. Press the **Up Arrow** or **Down Arrow** key to scroll the alarm sequence numbers up or down and display information on previous alarms.

The higher the leftmost digit (alarm sequence number), the older the alarm data.

For descriptions of each alarm code, refer to 9.2 *Troubleshooting*.

The following are operator-related alarms which are not recorded in the traceback data.

Display	Description
	Digital operator transmission error 1
	Digital operator transmission error 2
	No error detected.

Note: Alarm traceback data is not updated when the same alarm occurs repeatedly.

7.2.2. JOG Operation

! CAUTION

- Forward Run Prohibited (/P-OT) and Reverse Run Prohibited (/N-OT) signals are not effective during JOG operations using parameter Fn002.

Operation from the digital operator allows the servo amplifier to run the motor. This allows checking the motor's rotation direction and speed setting rapidly during machine setup and testing, saving the time and trouble of connecting to a host controller.

For the motor speed setting procedure, refer to *7.1.5 Operation in Parameter Setting Mode* and *5.3.2 JOG Speed*.

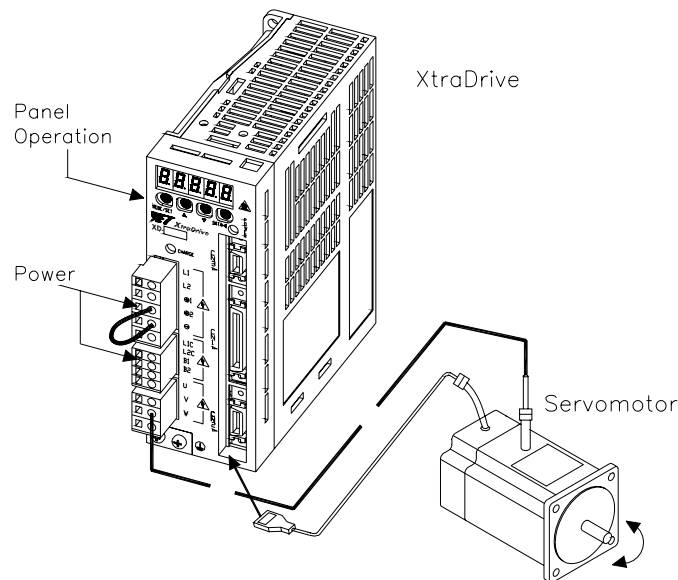

The operating procedure using the digital operator is described on the following pages.

1. Press the **MODE/SET** key to select Fn002 in the Auxiliary Function mode.

Fn002

2. Press the **DATA/SHIFT** key for a minimum of one second to select the Panel Operator Operation mode. Operation is now possible using the panel operator.

F. JOG

- Press the **MODE/SET** key to set the servo to ON (with motor power turned ON).

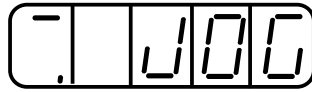

- Press the **Up Arrow** or **Down Arrow** key to operate the motor. The motor keeps operating while the key is pressed.

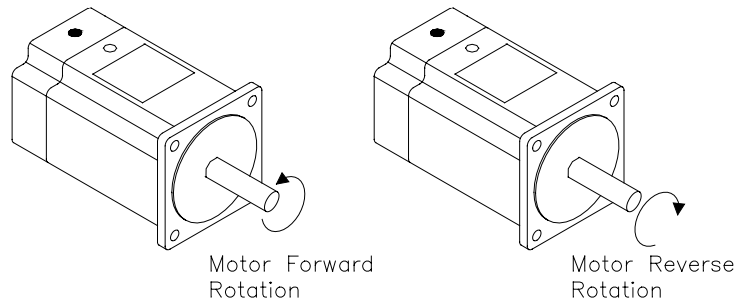

- Press the **MODE/SET** key to set the servo to OFF state (with motor power turned OFF). Alternatively, press the **DATA/SHIFT** key for a minimum of one second to set the servo to OFF state.
- Press the **DATA/SHIFT** key for a minimum of one second, and the display will revert to Fn002 in the Auxiliary Function mode.



This ends JOG operation under panel operator control.

The motor speed for operation under digital operator control can be changed with the following parameter:

Parameter	Signal	Setting (rpm)	Application
Pn304	Jog Speed	Default Setting: 500	Speed Control

Note: The rotation direction of the servomotor depends on the setting of parameter Pn000.0 "Rotation Direction." The above example shows a case where Pn000.0 is set to "0" as a default setting.

7.2.3. Automatic Adjustment of Speed and Torque Reference Offset

When speed and torque control are used, the motor may rotate slowly even when 0V is specified as the analog reference voltage. This occurs when the host controller or external circuit has a small offset (measured in mV) in the reference voltage.

The Automatic Reference Offset Adjustment mode automatically measures the offset and adjusts the reference voltage. It adjusts both the speed and torque references.

The following diagram illustrates the automatic adjustment of an offset in the reference voltage by the servo amplifier.

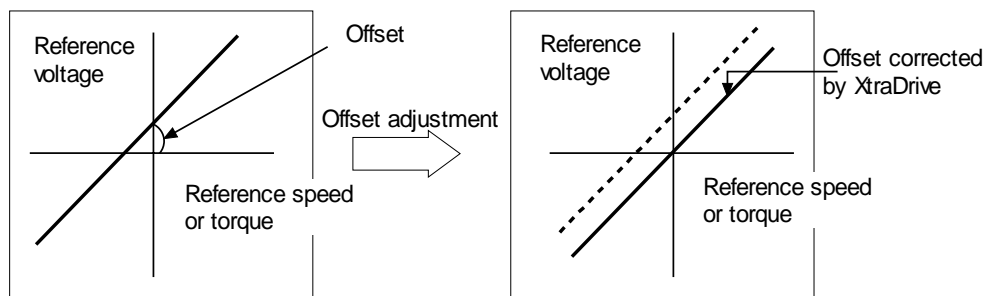

After completion of the automatic offset adjustment, the new offset value is stored in the servo amplifier.

The offset value can be checked in the Speed Reference Offset Manual Adjustment mode. Refer to 7.2.4 *Manual Adjustment of the Speed and Torque Reference Offset* for details.

The Automatic Reference Offset Adjustment mode cannot be used to set error pulses to zero for a stopped servo amplifier when a position loop is formed with a host controller. In such cases, use the Manual Reference Offset Adjustment mode. Refer to 7.2.4 *Manual Adjustment of the Speed and Torque Reference Offset* for details.

The zero-clamp speed control function is available to force the motor to stop while the zero speed reference is given. Refer to 5.4.3 *Using the Zero Clamp Function*.

IMPORTANT

- Automatic adjustment of the speed/torque reference offset must be performed in the servo OFF state.

Follow this procedure to automatically adjust the speed/torque reference offset.

1. Input the (intended) 0V reference voltage from the host controller or external circuit.

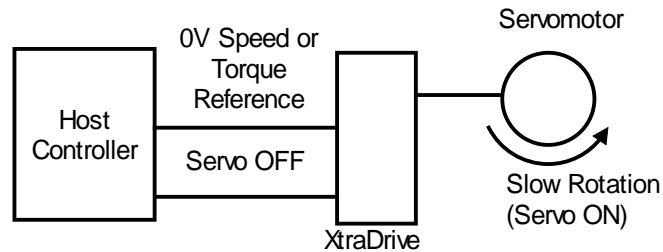

2. Press the **MODE/SET** key to select the Auxiliary Function mode.

Fn0000

3. Press the **Up Arrow** or **Down Arrow** key to select the parameter Fn009.

Fn009

4. Press the **DATA/SHIFT** key for a minimum of one second, and the display will be as shown below.

rEF_o

5. Press the **MODE/SET** key, and the following display will flash for one second. The reference offset will be automatically adjusted.

done → rEF_o

Flashing for one second

6. Press the **DATA/SHIFT** key for a minimum of one second to return to the Auxiliary Function mode display.

Fn009

This completes the automatic speed/torque reference offset adjustment.

7.2.4. Manual Adjustment of Speed and Torque Reference Offset

Manual speed/torque reference offset adjustment is useful in the following situations:

- If a position loop is formed with a host controller and the error zeroed-out when the motor was stopped in servo lock (zero reference)
- To deliberately set the offset to a specific value

This mode can also be used to check the data set in the Automatic Reference Offset Adjustment mode.

In principle, this mode operates in the same way as the Automatic Reference Offset Adjustment mode, except that the offset value is directly input during the adjustment. The offset value can be set in the speed reference or torque reference. The offset setting range and setting units are as follows:

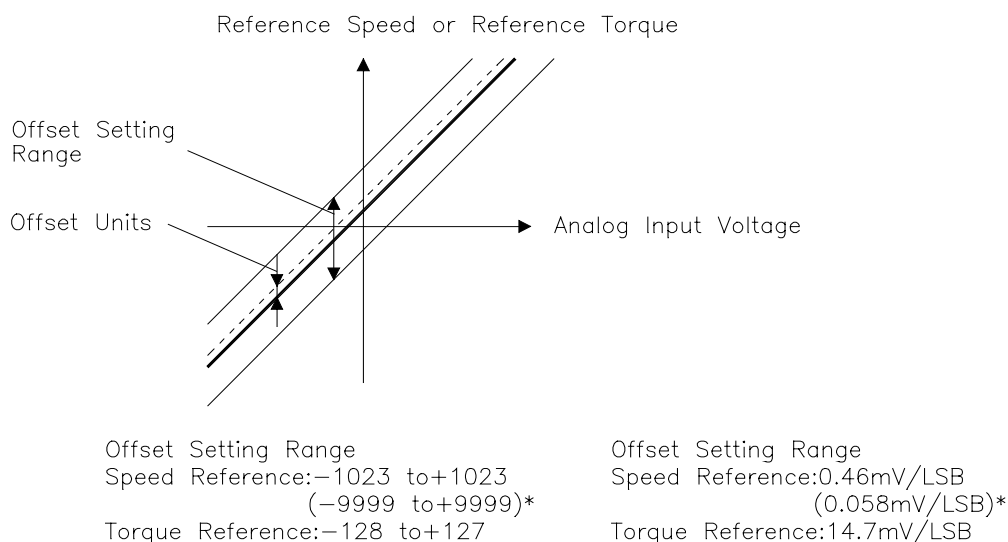

* Values in parentheses are for the SGDM-□□DA, and SGDM-□□ (Version 0006 or later).

Follow the procedure below to manually adjust the speed reference offset.

1. Press the **MODE/SET** key to select the Auxiliary Function mode.

A digital display showing the text "Fn000" in a segmented font, enclosed in a rectangular border.

2. Press the **Up Arrow** or **Down Arrow** key to select the parameter Fn00A.

A digital display showing the text "Fn00A" in a segmented font, enclosed in a rectangular border.

3. Press the **DATA/SHIFT** key for a minimum of one second, and the display will be as shown below. The manual adjustment mode for the speed reference offset will be entered.

A digital display showing the text "-.SPd" in a segmented font, enclosed in a rectangular border.

4. Turn ON the Servo ON (/S-ON) signal. The display will be as shown below.

A digital display showing the text ".SPd" in a segmented font, enclosed in a rectangular border.

5. Press the **DATA/SHIFT** key for less than one second to display the speed reference offset value.
6. Press the **Up Arrow** or **Down Arrow** key to adjust the offset value (adjustment of the speed reference offset).
7. Press the **DATA/SHIFT** key for less than one second to return to the display shown in step 4 above .
8. Press the **DATA/SHIFT** key to return to the Auxiliary Function mode display.

A digital display showing the text "Fn00A" in a segmented font, enclosed in a rectangular border.

This completes the manual speed reference offset adjustment.

■ Manual Adjustment of Torque Reference Offset

Follow the procedure below to manually adjust the torque reference offset.

1. Press the **MODE/SET** key to select the Auxiliary Function mode.

A digital display showing the text 'Fn0000' in a segmented font, indicating the Auxiliary Function mode.

2. Press the **Up Arrow** or **Down Arrow** key to select the parameter Fn00B.

A digital display showing the text 'Fn00b' in a segmented font, indicating the selected parameter.

3. Press the **MODE/SET** key for a minimum of one second, and the display will be as shown below. The manual adjustment mode for the torque reference offset will be entered.

A digital display showing the text '-.tr9' in a segmented font, indicating the manual adjustment mode.

4. Turn ON the Servo ON (/S-ON) signal. The display will be as shown below.

A digital display showing the text '.tr9' in a segmented font, indicating the Servo ON signal is active.

5. Press the **DATA/SHIFT** key for less than one second to display the torque reference offset value.

A digital display showing the text '0000' in a segmented font, indicating the torque reference offset value.

6. Press the **Up Arrow** or **Down Arrow** key to adjust the offset value (Adjustment of torque reference offset).
7. Press the **DATA/SHIFT** key for less than one second, and the display will be as shown in step 4 above.
8. Press the **DATA/SHIFT** key to return to the Auxiliary Function mode.

A digital display showing the text 'Fn00b' in a segmented font, indicating the Auxiliary Function mode is restored.

This completes the manual torque reference offset adjustment.

7.2.5. Clearing Alarm Traceback Data

This procedure clears the alarm history, which stores alarms generated in the servo amplifier. After clearing, each alarm in the alarm history is set to A.- -, which is not an alarm code. Refer to *7.2.1 Operation in Alarm Traceback Mode* for details.

Follow the procedure below to clear the alarm traceback data.

1. Press the **MODE/SET** key to select the Auxiliary Function mode.

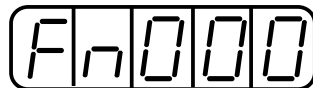

A digital display showing the text "Fn0000" in a seven-segment font.

2. Press the **Up Arrow** or **Down Arrow** key to select the parameter Fn006.

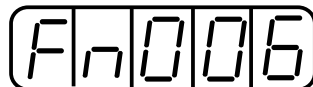

A digital display showing the text "Fn0006" in a seven-segment font.

3. Press the **DATA/SHIFT** key for a minimum of one second, and the display will be as shown below.

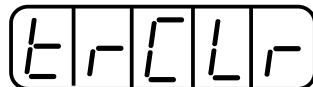

A digital display showing the text "ErCLr" in a seven-segment font.

4. Press the **MODE/SET** key to clear the alarm traceback data. The following display will flash for one second, and after the alarm traceback data is cleared, the display will return to show as above in step 3.

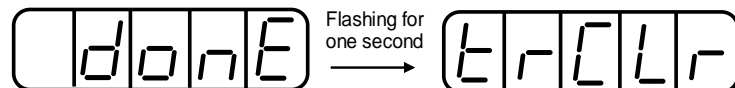

A diagram showing the transition of the display. On the left, a digital display shows "done" in a seven-segment font. An arrow points to the right, with the text "Flashing for one second" above it. On the right, a digital display shows "ErCLr" in a seven-segment font.

5. Press the **DATA/SHIFT** key for a minimum of one second to return to the parameter code display.



A digital display showing the text "Fn0006" in a seven-segment font.

This completes the alarm traceback data clearing procedure.

7.2.6. Checking the Motor Model

Set the parameter Fn011 to select the Motor Model Check mode. This mode is used for motor maintenance and can also be used to check the special (Y-specification) codes of the servo amplifiers.

Follow the procedure below to check the motor model.

1. Press the **MODE/SET** key to select the Auxiliary Function mode.

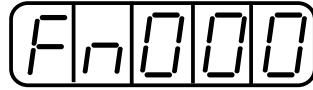

Fn000

2. Press the **Up Arrow** or **Down Arrow** key to select the parameter Fn011.



Fn011

3. Press the **DATA/SHIFT** key for a minimum of one second to display the servomotor model and voltage code.

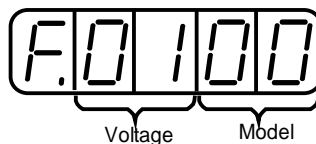

F.0100
Voltage Model

Voltage		Servomotor Model	
Code	Voltage	Code	Servomotor Model
00	100V _{AC} or 140V _{DC}	00	SGMAH
01	200V _{AC} or 280V _{DC}	01	SGMPH
02	400V _{AC} or 560V _{DC}	02	SGMSH
		03	SGMGH-□A (1500rpm)
		04	SGMGH-□B (1000rpm)
		05	SAGMDH
		06	SGMUH

4. Press the **MODE/SET** key to display the Servomotor capacity.

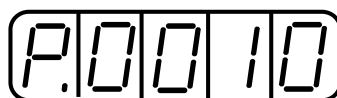

P.0010

Capacity: Displayed value x10 (W)
In this example, the capacity is 100W.

5. Press the **MODE/SET** key, and the encoder type and resolution code will be displayed.

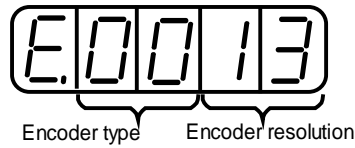

Encoder Type	
Code	Voltage
00	Incremental Encoder
01	Absolute Encoder

Encoder Resolution	
Code	Resolution
13	13 bits
16	16 bits
17	17 bits
20	Reserved

6. Press the **MODE/SET** key to display the servo amplifier's special (Y-specification) code.

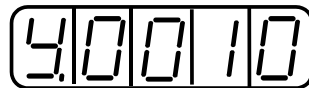

This example shows specification "Y10" (indicated in decimal).

7. Press the **DATA/SHIFT** key to return to the Auxiliary Function mode display.
Pressing the **DATA/SHIFT** key after the above displays in steps 3 to 5 will also return to the Auxiliary Function mode display.

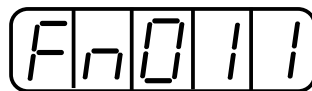

This completes the motor type checking procedure.

7.2.7. Checking the Software Version

Set Fn012 to select the Software Version Check mode. This mode is used for motor maintenance.

Follow the procedure below to check the software version.

1. Select the parameter Fn012.
2. Press the **DATA/SHIFT** key for a minimum of one second to display the servo amplifier software version.

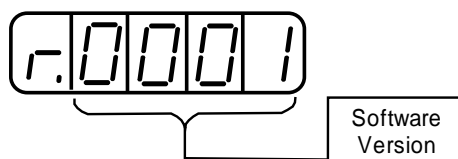

3. Press the **MODE/SET** key to display the encoder software version.

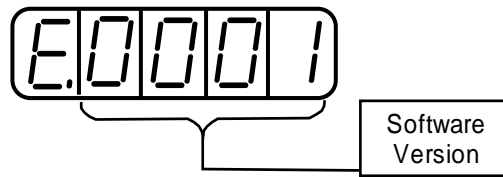

4. Press the **DATA/SHIFT** key for a minimum of one second to return to the parameter code display.

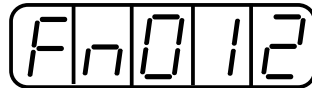

7.2.8. Origin Search Mode

! CAUTION

- Forward run prohibited (/P-OT) and reverse run prohibited (/N-OT) signals are not effective during jog operations using parameter Fn003.

The Origin Search mode is designed to position the origin pulse position of the encoder and to clamp at the position. This mode is used when the motor shaft needs to be aligned to the machine. Execute the origin search without connecting the couplings.

The speed for executing the origin search is 60rpm.

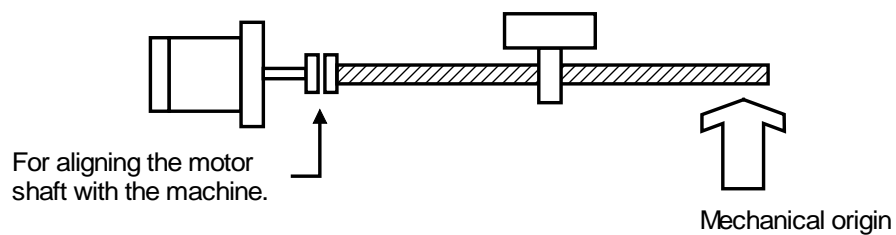

The following conditions must be met to perform the origin search operation.

- If the Servo-ON input signal (/S-ON) is ON, turn it OFF.
- Release the Servo-ON signal mask when the parameter Pn50A.1 is set to 7, and the servo has been set to be always ON.

Follow the procedure below to execute the origin search.

1. Press the **MODE/SET** key to select the Auxiliary Function mode.

The LCD display shows the text "Fn000" in a segmented font, indicating the Auxiliary Function mode.

2. Press the **Up Arrow** or **Down Arrow** key to select the parameter Fn003.

The LCD display shows the text "Fn003" in a segmented font, indicating the selected parameter.

3. Press the **DATA/SHIFT** key for a minimum of one second, and the display will be as shown below.

The LCD display shows the text ". . C S r" in a segmented font, indicating the origin search mode.

4. Press the **DSPL/SET** key, and the display will change as shown below. Now it is ready for executing the origin search.

The LCD display shows the text ". . C S r" in a segmented font, indicating the origin search mode.

5. Hold down **Up Arrow** or **Down Arrow** key to execute the origin search. When the parameter is set to Pn000.0 = 0 (default), pressing the **Up Arrow** key will rotate the motor in forward direction. Pressing the **Down Arrow** key will rotate the motor in reverse direction. When the parameter is set to Pn000.0 = 1, the rotation of the motor is reversed.

The diagram shows the LCD display ". . C S r" with an arrow pointing to the right. Above the arrow is the text "UP: Forward" and below it is "DOWN: Reverse". To the right of the arrow is another ". . C S r" display with the text "Keeps flashing until origin search is completed." next to it.

6. Press the **DATA/SHIFT** key for a minimum of one second to return to the Auxiliary Function mode display.

The LCD display shows the text "Fn003" in a segmented font, indicating the Auxiliary Function mode.

This completes the origin search operation.

7.2.9. Initializing Parameter Settings

This function is used to reset all parameters to the default settings (standard factory settings).

IMPORTANT

- Initialize the parameter settings with the servo OFF.
- After performing the procedure, cycle the power to reset all the parameters to the default settings.

Follow the procedure below to initialize parameter settings.

1. Press the **MODE/SET** key to select the Auxiliary Function mode.

Fn000

2. Press the **Up Arrow** or **Down Arrow** key to select parameter Fn005.

Fn005

3. Press the **DATA/SHIFT** key for a minimum of one second, and the display will be as shown below.

P. In It

4. Press the **MODE/SET** key, and the display will be as shown below. The parameters will be initialized.

P. In It Flashing during initialization → End

done Flashing for one second → P. In It

5. Press the **DATA/SHIFT** key for a minimum of one second to return to the Auxiliary Function mode display.

Fn005

This completes the initialization of parameter settings.

Note: Parameters will not be initialized by pressing the **DSPL/SET** or **MODE/SET** key with the servo **ON**. Turn the power **OFF** and then back **ON** after initialization.

7.2.10. Manual Zero Adjustment and Gain Adjustment of Analog Monitor Output

Motor speed, torque reference, and position error can be monitored through the analog monitor output. Refer to 6.6 *Analog Monitor*.

Use the manual zero adjustment function to compensate for the output voltage drift or the zero point drift caused by noise entering the monitor system. The gain adjustment function can be changed to match the sensitivity of the measuring system.

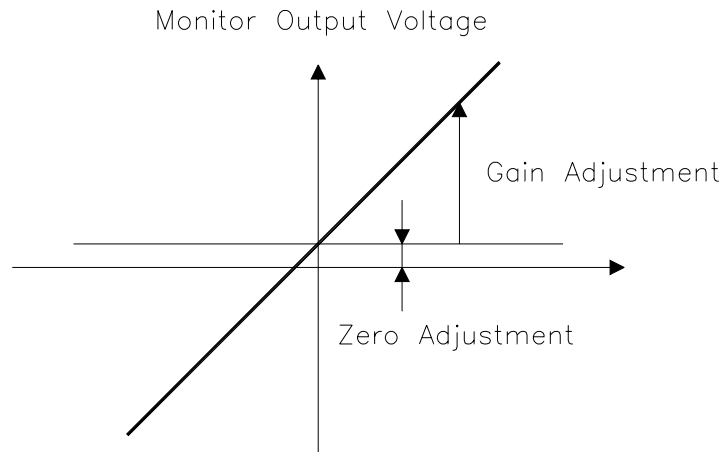

	Setting Unit
Zero Setting Range: $\pm 2V$	$\rightarrow 17mV/LSB$
Gain Setting Range: 50 to 150%	$\rightarrow 0.4\%/LSB$

Note: The output voltage of the analog monitor is $\pm 8V$. The output voltage polarity will be reversed if $\pm 8V$ is exceeded.

■ Manual Zero Adjustment of Analog Monitor Output

Follow the procedure below to execute the manual zero adjustment of analog monitor output.

1. Press the **MODE/SET** key to select the Auxiliary Function mode.

F_n0000

2. Press the **Up Arrow** or **Down Arrow** key to select the parameter **F_n00C**.

F_n000C

3. Press the **DATA/SHIFT** key for a minimum of one second, and the display will be as shown below.

A digital display with five segments showing the characters 'C', 'H', '1', '_', and '0' in a monospace font.

4. Press the **MODE/SET** key. Each time the **MODE/SET** key is pressed, the monitor output will toggle between the displays for the two channels shown below.

Two digital displays are shown side-by-side. The left display shows 'CH1_0' and the right display shows 'CH2_0'. A double-headed arrow between them is labeled 'MODE/SET key' above and 'Displayed alternately' below.

5. Press the **DATA/SHIFT** key for less than one second, and the analog monitor gain parameter will be displayed. Pressing the **DATA/SHIFT** key again for less than one second will return to the display shown in steps 3 or 4 above.

Two digital displays are shown side-by-side. The left display shows 'CH2_0' and the right display shows '0000'. A double-headed arrow between them is labeled 'MODE/SET key' above and 'Displayed alternately' below. The text 'Data display' is positioned above the right display.

6. Press the **Up Arrow** or **Down Arrow** key to perform zero adjustment of the analog monitor output.

Two digital displays are shown side-by-side. The left display shows '0000' and the right display shows '-0001'. A single-headed arrow points from the left to the right, with the text 'Data setting change' above it.

7. When zero adjustment has been completed for the two channels, press the **DATA/SHIFT** key for a minimum of one second to return to the Auxiliary Function mode display.

A digital display with five segments showing the characters 'F', 'n', '0', '0', and '0' in a monospace font.

This completes the manual zero adjustment of the analog monitor output.

Manual Gain Adjustment of Analog Monitor Output

Follow the procedure below to execute the manual gain adjustment of analog monitor output.

1. Press the **MODE/SET** key to select the Auxiliary Function mode.

A digital display showing the text "Fn000" in a seven-segment font.

2. Press the **Up Arrow** or **Down Arrow** key to select parameter Fn00D.

A digital display showing the text "Fn00d" in a seven-segment font.

3. Press the **DATA/SHIFT** key for at least one second, and the display will be as shown below.

A digital display showing the text "CH1_0" in a seven-segment font.

4. Press the **MODE/SET** key. Each time the **MODE/SET** key is pressed, the monitor output will toggle between the displays for the two channels shown below.

A diagram showing two digital displays: "CH1_0" on the left and "CH2_0" on the right. A double-headed arrow between them is labeled "MODE/SET key" above and "Displayed alternately" below.

5. Press the **DATA/SHIFT** key for less than one second, and the analog monitor gain parameter will be displayed. Pressing the **DATA/SHIFT** key again for less than one second will return to the display shown in steps 3 or 4 above.

A diagram showing two digital displays: "CH2_0" on the left and "0000" on the right. A double-headed arrow between them is labeled "DATA/SHIFT key" above and "Displayed alternately" below. The "0000" display is also labeled "Data display" above.

6. Press the **Up Arrow** or **Down Arrow** key to adjust the gain for the analog monitor output.

A diagram showing a digital display changing from "0000" to "0001". An arrow points from the first display to the second, with the text "Data setting change" above it.

7. When gain adjustment has been completed for the two channels, press the **DATA/SHIFT** key for a minimum of one second to return to the Auxiliary Function mode display.

A digital display showing the text "Fn00d" in a seven-segment font.

This completes the manual gain adjustment of the analog monitor output.

7.2.11. Adjusting the Motor Current Detection Offset

Motor current detection offset adjustment is performed at Yaskawa before shipping. Normally, the user does not need to perform this adjustment. Make this adjustment only if highly accurate adjustment is required to reduce torque ripple caused by current offset.

! CAUTION

- If this function, particularly manual adjustment, is executed carelessly, it may degrade the performance of the servo drive.

The following sections describe automatic and manual adjustment of the current detection offset.

■ Automatic Adjustment of the Motor Current Detection Offset

IMPORTANT

- Automatic adjustment is possible only with power supply to the main circuits ON and with the servo OFF.

Use the following procedure to perform automatic adjustment of the current detection offset.

1. Press the **MODE/SET** key to select the Auxiliary Function mode.

Fn000

2. Press the **Up Arrow** or **Down Arrow** key to select the parameter Fn00E.

Fn00E

3. Press the **DATA/SHIFT** key for a minimum of one second, and the display will be as shown below.

Cur_o

4. Press the **MODE/SET** key. The display will change as shown below, and the offset will be automatically adjusted.

done → Cur_o

Flashing for one second

5. Press the **DATA/SHIFT** key for a minimum of one second to return to the Auxiliary Function mode display.

The LCD display shows the text 'Fn00E' in a segmented font, where 'Fn' is in the first two segments and '00E' is in the last three segments.

This completes the automatic adjustment of the motor current detection offset.

■ Manually Adjusting the Motor Current Detection Offset

Follow the procedure below to manually adjust the current detection offset.

IMPORTANT

- When making manual adjustments, run the motor at a speed of approximately 100rpm, and adjust the Motor Current Detection Offset until the torque ripple, observed with the analog monitor, is minimized. (Refer to *Section 6.5 Analog Monitor*.) Adjust the U-phase and V-phase offsets alternately several times until these offsets are well balanced.

1. Press the **MODE/SET** key to select the Auxiliary Function mode.

The LCD display shows the text 'Fn0000' in a segmented font, where 'Fn' is in the first two segments and '0000' is in the last four segments.

2. Press the **Up Arrow** or **Down Arrow** key to select the parameter Fn00F.

The LCD display shows the text 'Fn00F' in a segmented font, where 'Fn' is in the first two segments and '00F' is in the last three segments.

3. Press the **DATA/SHIFT** key for a minimum of one second, and the display will be as shown below.

The LCD display shows the text 'Cu1_0' in a segmented font, where 'Cu' is in the first two segments, '1' is in the third, and '_0' is in the last two.

4. Press the **MODE/SET** key to switch between U-phase (Cu1_0) and V-phase (Cu2_0) current detection offset adjustment mode.

The diagram shows two LCD displays: 'Cu1_0' on the left and 'Cu2_0' on the right. A double-headed arrow between them is labeled 'MODE/SET key' above and 'Displays alternately' below.

5. Press the **DATA/SHIFT** key for less than one second to display the current detection data. Press the **DATA/SHIFT** key again for less than one second, and the display will return to show as in step 3 or 4 above.

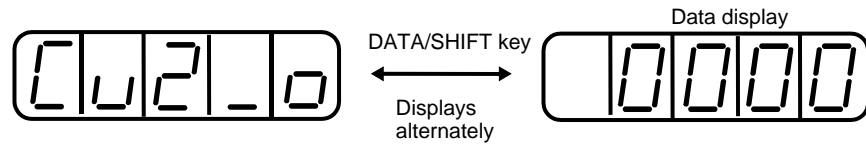

6. Press the **Up Arrow** or **Down Arrow** key to adjust the offset. Carefully adjust the offset while monitoring the torque reference monitor signal.

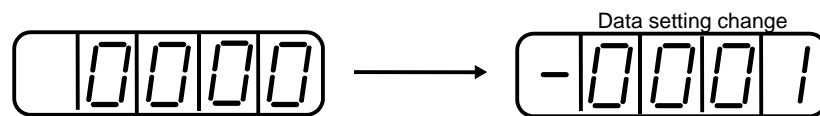

7. When the current offset adjustment has been completed for the U-phase (Cu1_0) and V-phase (Cu2_0), press the **DATA/SHIFT** key to return to the Auxiliary Function mode display.



This completes the manual adjustment of the motor current detection offset.

7.2.12. Write Protection Setting

The write protection setting is used to prevent careless changes of parameters. Pn□□□ parameters and some of the Fn□□□ parameters become write protected by setting the parameter Fn010.

Password setting values are as follows:

- “0000”: Write enabled (releases write protected mode.)
- “0001”: Write prohibited (parameters become write protected at the next power ON.)

Follow the procedure below to set the write protection feature.

1. Press the **MODE/SET** key to select the Auxiliary Function mode.
2. Press the **Up Arrow** or **Down Arrow** key to select the parameter Fn010.



3. Press the **DATA/SHIFT** key for a minimum of one second, and the display will be as shown below.

P.0000

4. Input the value (0001) and press the **MODE/SET** key. The display will change as shown below and the write protection will be established.

done Flashing for one second → P.0001

5. Press the **DATA/SHIFT** key for a minimum of one second to return to the Auxiliary Function mode display.

Fn010

This completes the procedure for setting the write protection. The new password setting will be valid after the next power OFF/ON cycle.

7.2.13. Clearing the Option Unit Detection Alarm

Alarm A.E7 (option unit detection failure) occurs the first time that the XtraDrive servo amplifier is turned ON after disconnecting an option board.

IMPORTANT

- Initialize the parameter settings with the servo OFF.
- After performing the procedure, cycle the power to reset all parameters to the default settings.
- Because the parameter has been set for the XtraDrive connected to an option board, be sure to adjust the setting or initialize the parameter value (Fn005 of the Auxiliary Function mode) to meet the current system needs.

Use the following procedure to initialize parameter settings.

1. Press the **MODE/SET** key to select the Auxiliary Function mode.

The LCD display shows the text "Fn000" in a segmented font, indicating the Auxiliary Function mode.

2. Select the parameter Fn014.

Press the **Left Arrow** or **Right Arrow** key to select the digit.

Press the **Up Arrow** or **Down Arrow** key to change the value.

The LCD display shows the text "Fn014" in a segmented font, indicating the selected parameter.

3. Press the **DATA/SHIFT** key for a minimum of one second, and the display will be as shown below.

The LCD display shows the text "oInIt" in a segmented font, indicating the initialization process.

4. Press the **MODE/SET** key, and the display will be as shown below. The parameters will be initialized.

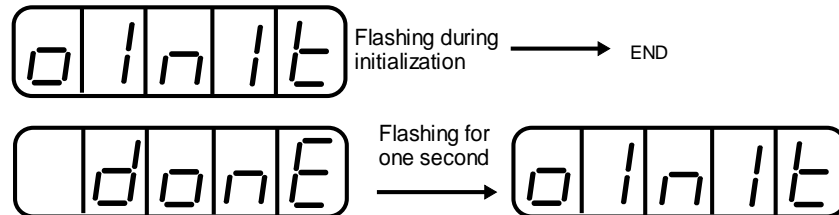

5. Press the **DATA/SHIFT** key for a minimum of one second to return to the Auxiliary Function mode display.

The LCD display shows the text "Fn014" in a segmented font, indicating the Auxiliary Function mode display.

This completes the initialization of parameter settings.

8. Ratings, Specifications and Dimensional Drawings

This chapter provides the ratings, torque-speed characteristics diagrams, and dimensional drawings of the XtraDrive series servo drives.

8.1.	Ratings and Specifications	8-2
8.2.	Single-phase 200V XtraDrive and Motors Combinations	8-6
8.3.	Three-phase 200V XtraDrive and Motor Combinations	8-7
8.4.	Three-phase 400V XtraDrive and Motors Combinations	8-8
8.5.	Base-mounted Dimensional Drawings	8-10
8.5.1.	XD-P3 to -02 (1-phase 200V, 30 to 200 W)	8-10
8.5.2.	XD-04 (1-phase 200 V, 400 W)	8-11
8.5.3.	XD-08 (1-phase 200V,0.75kW)and XD-10(3-phase 200V, 1.0kW)	8-12
8.5.4.	XD-05, 10, 15 (3-phase 400V, 0.5 to 1.5kW)	8-13
8.5.5.	XD-20, -30 (3-phase 200V,400V, 2.0 and 3.0 kW)	8-14
8.6.	Rack-mounted Dimensional Drawings	8-15
8.6.1.	XD-P3 to -02 (1-phase 200V, 30 to 200 W)	8-15
8.6.2.	XD-04 (1-phase 200 V, 400 W)	8-16
8.6.3.	XD-08 (1-phase 200V, 0.75kW)and XD-10(3-phase 200V,1.0kW)	8-17
8.6.4.	XD-05, 10, 15 (3-phase 400V, 0.5 to 1.5kW)	8-18
8.6.5.	XD-20, -30 (3-phase 200V,400V, 2.0 and 3.0 kW)	8-19

8.1. Ratings and Specifications

The following table shows ratings and specifications for the XtraDrive servo amplifier to use in selecting the appropriate servo amplifier.

■ XtraDrive Ratings and Specifications

The table's input current rates are at the lower range of the voltage specifications.

XtraDrive Model XD-		P3	P5	01	02	04	05	08	10	15	20	30	
Applicable Servomotor	200V	SGMAH-□A	A3	A5	01	02	04	—	08	—	—	—	
		SGMPH-□A	—	—	01	02	04	—	08	—	15	—	
		SGMGH-□A□A (1500rpm)	—	—	—	—	—	05	—	09	13	20	30
		SGMSH-□A	—	—	—	—	—	—	—	10	15	20	30
	400V	SGMAH-□D	—	—	—	—	—	03	—	—	—	—	22
		SGMPH-□D	—	—	—	—	—	02 04	—	08	15	—	—
		SGMGH-□D	—	—	—	—	—	05	—	09	13	20	30
		SGMSH-□D	—	—	—	—	—	—	—	10	15	20	30
		SGMUH-□D	—	—	—	—	—	—	—	10	15	—	30
	Basic Specifications	Maximum Applicable Servomotor Capacity [kW]		0.03	0.05	0.1	0.2	0.4	0.45	0.75	1.0	1.5	2.0
200V		Continuous Output Current [A _{rms}]	0.44	0.64	0.91	2.1	2.8	3.8	5.7	7.6	11.6	18.5	24.8
		Maximum Output Current [A _{rms}]	1.3	2.0	2.8	6.5	8.5	11.0	13.9	17	28	42	56
400V		Continuous Output Current [A _{rms}]	—	—	—	—	—	1.9	—	3.5	5.4	8.4	11.9
	Maximum Output Current [A _{rms}]	—	—	—	—	—	5.5	—	8.5	14	20	28	

XtraDrive Ratings and Specifications (continued)

XtraDrive Model XD-			01	02	04	05	08	10	15	20	30	
Basic Specifications	Input Power Supply*	Main Circuit	200V	Single/Three-phase 200 to 230V _{ac} +10 to -15%, 50/60Hz *								
			400V	Three-phase. 380 to 480V _{AC} +10 to -15%, 50/60Hz								
		Control Circuit	200V	For Single-phase 200 to 230.5V _{ac} +10 to -15%, 50/60Hz								
			400V	24V _{DC} ±15%, 0.7A								
	Control Method		Single or three-phase full-wave rectification IGBT-PWM (sine wave driven)									
	Feedback		Serial encoder: 13- (incremental only), 16-, or 17-bit (incremental/absolute).									
	Conditions	Ambient/Storage Temperature **	0 to +55°C/-20 to +85°C (When enclosed, internal temperatures must not exceed this range.)									
		Ambient/Storage Humidity	90% relative humidity or less (with no condensation)									
		Vibration/Shock Resistance	4.9 m/s ² /19.6 m/s ²									
	Configuration		Base mounted (Rack mounted optional).									
XtraDrive Model XD-			01	02	04	05	08	10	15	20	30	
Approx. Mass [kg (lb)]	For 200V		0.8 (1.76)	1.1 (2.43)	—							
				0.8 (1.76)	1.1 (2.43)	1.7 (3.75)			2.8 (6.17)	3.8 (8.38)		
	For 400V		—	—	1.7 (3.75)	—	1.7 (3.75)					

* Supply voltage must not exceed 230V +10% (253V). A step-down transformer is required if the voltage exceeds these values.

**Use the servo amplifier within the ambient temperature range. When enclosed, internal temperatures must not exceed the specified range.

XtraDrive Ratings and Specifications (continued)

XtraDrive Model XD-		P3	P5	01	02	04	05	08	10	15	20	30	
Speed and Torque Control Modes	Performance	Speed Control Range		1:5000 (The lowest speed of the speed control range is the point just before the motor stops under full-load condition.)									
		Speed Regulation *	Load Regulation	0 to 100% load: 0.01% maximum (at rated speed)									
			Voltage Regulation	Rated Voltage $\pm 10\%$: 0% (at rated speed)									
			Temperature Regulation	$25 \pm 25^\circ\text{C}$: $\pm 0.1\%$ max. (at rated speed)									
		Frequency Characteristics		400Hz (at $J_L = J_M$)									
		Torque Control Tolerance (Repeatability)		$\pm 2\%$									
		Soft Start Time Setting		0 to 10s (Can be set individually for acceleration and deceleration)									
	Input Signals	Speed Reference Input	Reference Voltage**	$\pm 6V_{DC}$ (Variable setting range: ± 2 to $\pm 10V_{DC}$) at rated torque (positive torque reference with positive reference), input voltage: $\pm 12V$ (maximum).									
			Input Impedance	About 14k Ω									
			Circuit Time Constant	—									
		Torque Reference Input	Reference Voltage**	$\pm 3V_{DC}$ (Variable setting range: ± 1 to $\pm 10V_{DC}$) at rated torque (positive torque reference with positive reference), input voltage: $\pm 12V$ (maximum)									
			Input Impedance	About 14k Ω									
			Circuit Time Constant	About 47 μs									
		Contact Speed Reference	Rotation Direction Selection	With P control signal									
Speed Selection			With forward/reverse current limit signal (speed 1 to 3 selection), servomotor stops or another control method is used when both are OFF.										
Position Control Mode		Performance	Bias Setting		0 to 450rpm (setting resolution: 1rpm)								
	Feed Forward Compensation		0 to 100% (setting resolution: 1%)										
	Positioning Completed Width Setting		0 to 250 reference units (setting resolution: 1 reference unit)										
	Input Signals	Reference Pulse	Type	Sign + pulse train, 90° phase difference 2-phase pulse (A phase + B phase), or CCW + CW pulse train									
			Form	Line driver (+5V level), open collector (+5V or +12V level)									
			Frequency	500/200kpps maximum (line driver/open collector).									
	Control Signal		Clear Signal (input pulse form identical to reference pulse)										
Built-in Open-Collector Power Supply***		+12V (1k Ω built-in resistor)											

* Speed regulation is defined as follows:

The motor speed may change due to voltage variations or amplifier drift and changes in processing resistance due to temperature variation. The ratio of speed changes to the rated speed represents speed regulation due to voltage and temperature variations.

** Forward is clockwise viewed from the non-load side of the servomotor, (counterclockwise viewed from the load and shaft end).

***The built-in open collector power supply is not electrically isolated from the control circuit in the servo amplifier.

XtraDrive Ratings and Specifications (continued)

XtraDrive Model XD-		P3	P5	01	02	04	05	08	10	15	20	30	
I/O Signals	Position	Form	A -, B -, C - phase line driver S - phase line driver (only with an absolute encoder)										
		Frequency Dividing Ratio	Any										
	Sequence	Signal allocation can be modified	Servo ON, P control (or Control Mode switching, forward/reverse motor rotation by internal speed setting, zero clamping, reference pulse prohibited), forward run prohibited (P-OT), reverse run prohibited (N-OT), alarm reset, forward current limit, and reverse current limit (or internal speed selection)										
	Sequence	Fixed Output	Servo alarm, 3-bit alarm codes.										
Internal Functions		Signal allocation can be modified	Positioning completed (speed coincidence), during servomotor rotation, servo ready, during current limiting, during speed limiting, brake released, warning, selecting three of the NEAR signals.										
		Dynamic Brake	Operated at main power OFF, servo alarm, servo OFF, or overtravel.										
		Regeneration	External regenerative resistor.					Built-in.					
		Overtravel Stop	Dynamic brake stops at P-OT or N-OT, deceleration to a stop, or free run to a stop.										
		Electronic Gear	$0.01 \leq A/B \leq 100$										
		Protection	Overcurrent, overvoltage, low voltage, overload, regeneration error, main circuit voltage error, heat sink overheated, no power supply, overflow, overspeed, encoder error, overrun, CPU error, parameter error, etc.										
		LED Display	Charge, Power, five 7-segment LEDs (built-in digital operator functions)										
		CN5 Analog Monitoring	Analog monitor connector built in for monitoring speed, torque and other reference signals. Speed: 1V/1000rpm Torque: 1V/rated torque Pulses remaining: 0.05V/reference unit or 0.05V/100 reference units										
	Communications		Connected Devices	Digital operator (hand-held model), RS-422A port such as for a personal computer (RS-232C ports under certain conditions)									
			1:N Communications	Up to N = 14 for RS-422A ports									
			Axis Address Setting	Set with parameters.									
			Functions	Status display, parameter setting, monitor display, alarm trace-back display, JOG and auto-tuning operations, speed, torque reference signal, and other drawing functions									
			Others	Reverse rotation connection, origin search, automatic servomotor ID, DC reactor connection terminal for high power supply frequency control*									

8.2. Single-phase 200V XtraDrive and Motors Combinations

XtraDrive Model XD-		P3- ^{**}	P5- ^{**}	01- ^{**}	02- ^{**}	04- ^{**}	08- ^{**}	
SGMAH Series (Yaskawa or compatible)	Applicable Servomotor	Model SGMAH-	A3A	A5A	01A	02A	04A	08A
		Capacity (KW)	0.03	0.05	0.1	0.2	0.4	0.75
		Motor Speed (Rpm)	Rated 3000/maximum 5000					
		Applicable Encoder	YASKAWA serial or incremental A quad B or absolute encoder. DIFFERENT incremental A quad B encoders					
		Continuous Output Current A_{rms}	0.44	0.64	0.91	2.1	2.8	4.4
		Maximum Output Current A_{rms}	1.3	2.0	2.8	6.5	8.5	13.4
		Allowable Regenerative Energy* (Joules)	18.5			37.1		—
SGMPH Series (Yaskawa or compatible)	Applicable Servomotor	Model SGMPH-	—	—	01A	02A	04A	08A
		Capacity (KW)	—	—	0.1	0.2	0.4	0.75
		Motor Speed (Rpm)	Rated 3000/maximum 5000					
		Applicable Encoder	YASKAWA serial or incremental A quad B or absolute encoder. DIFFERENT incremental A quad B encoders					
		Continuous Output Current A_{rms}	—	—	0.89	2.0	2.6	4.1
		Maximum Output Current A_{rms}	—	—	2.8	6.0	8.0	13.9
		Allowable Regenerative Energy* (Joules)	—			37.1		—

* Allowable regenerative energy is the value with an AC input power supply voltage of 200 Vrms. The allowable regenerative energy may vary with power supply fluctuations.

8.3. Three-phase 200V XtraDrive and Motor Combinations

XtraDrive Model XD-		08- ^{**}	10- ^{**}	20- ^{**}	30- ^{**}	
SGMGH Series (Yaskawa or compatible)	Applicable Servomotor	Model SGMGH-	—	09A□A	20A□A	30A□A
		Capacity (KW)	—	0.85	1.3	1.8
		Motor Speed (Rpm)	Rated 1500/maximum 3000			
	Applicable Encoder		YASKAWA serial or incremental A quad B or absolute encoder. DIFFERENT incremental A quad B encoders			
	Continuous Output Current A_{rms}		—	7.1	16.7	23.8
	Maximum Output Current A_{rms}		—	17	42	56
	Allowable Regenerative Frequency* (times/min)		—	13	12	8
	Applicable Servomotor	Model SGMGH-	06A□B	09A□B	20A□B	30A□B
		Capacity (KW)	0.6	0.9	2.0	3.0
		Motor Speed (Rpm)	Rated 1000/maximum 2000			
	Applicable Encoder		YASKAWA serial or incremental A quad B or absolute encoder. DIFFERENT incremental A quad B encoders			
	Continuous Output Current A_{rms}		5.7	7.6	18.5	24.8
	Maximum Output Current A_{rms}		13.9	16.6	42	56
	Allowable Regenerative Frequency* (times/min)		39	22	20	13

* Allowable regenerative frequency is the allowable frequency in the motor while accelerating and decelerating through a 0 → maximum motor speed → 0(r/min) cycle.

8.4. Three-phase 400V XtraDrive and Motors Combinations

XtraDrive Model XD-		05- ^{**}	10- ^{**}	15- ^{**}	20- ^{**}	30- ^{**}		
SGMAH Series (Yaskawa or compatible)	Applicable Servomotor	Model SGMAH-	03D	07D	—	—	—	
		Capacity (KW)	0.3	0.65	—	—	—	
	Motor Speed (Rpm)	Rated 3000/maximum 5000						
	Applicable Encoder	YASKAWA serial or incremental A quad B or absolute encoder. DIFFERENT incremental A quad B encoders						
	Continuous Output Current A_{rms}	1.3	2.2	—	—	—		
	Maximum Output Current A_{rms}	5.5	8.5	—	—	—		
	Allowable Regenerative Frequency* (times/min)	42	15	—	—	—		
SGMPH Series (Yaskawa or compatible)	Applicable Servomotor	Model SGMPH-	02D	04D	10D	15D	—	—
		Capacity (KW)	0.2	0.4	1.0	—	—	—
	Motor Speed (Rpm)	Rated 3000/maximum 5000						
	Applicable Encoder	YASKAWA serial or incremental A quad B or absolute encoder. DIFFERENT incremental A quad B encoders						
	Continuous Output Current A_{rms}	1.4	1.4	2.6	4.5	—	—	
	Maximum Output Current A_{rms}	4.6	4.4	7.8	13.7	—	—	
	Allowable Regenerative Frequency* (times/min)	480	239	32	16	—	—	
SGMGH Series (Yaskawa or compatible)	Applicable Servomotor	Model SGMGH-	05D	09 D	13D	20D	30D	
		Capacity (kW)	0.45	0.85	1.3	1.8	2.9	
	Motor Speed (rpm)	Rated 1500/maximum 3000						
	Applicable Encoder	YASKAWA serial or incremental A quad B or absolute encoder. DIFFERENT incremental A quad B encoders						
	Continuous Output Current A_{rms}	1.9	3.5	5.4	8.4	11.9		
	Maximum Output Current A_{rms}	5.5	8.5	14	20	28		
	Allowable Regenerative Frequency* (times/min)	42	15	10	12	8		

* Allowable regenerative frequency is the allowable frequency in the motor while accelerating and decelerating through a 0 → maximum motor speed → 0(r/min) cycle.

Three-phase 400V XtraDrive and Motors Combinations (continued)

XtraDrive Model XD-		05- ^{**}	10- ^{**}	15- ^{**}	20- ^{**}	30- ^{**}	
SGM5H Series (Yaskawa or compatible)	Applicable Servomotor	Model SGM5H-	—	10D	15D	20D	30D
		Capacity (KW)	—	1.0	1.5	2.0	3.0
		Motor Speed (Rpm)	Rated 3000/maximum 5000				
	Applicable Encoder		YASKAWA serial or incremental A quad B or absolute encoder. DIFFERENT incremental A quad B encoders				
	Continuous Output Current A_{rms}		—	2.8	4.7	6.2	8.9
	Maximum Output Current A_{rms}		—	8.5	14	19.5	28
	Allowable Regenerative Frequency* (times/min)		—	47	31	48	20
SGM6H Series (Yaskawa or compatible)	Applicable Servomotor	Model SGM6H-	—	10D	15D	—	30D
		Capacity (KW)	—	1.0	1.5	—	3.0
		Motor Speed (Rpm)	Rated 6000/maximum 6000				
	Applicable Encoder		YASKAWA serial or incremental A quad B or absolute encoder. DIFFERENT incremental A quad B encoders				
	Continuous Output Current A_{rms}		—	2.7	4.1	—	8.1
	Maximum Output Current A_{rms}		—	8.5	14	—	28
	Allowable Regenerative Frequency* (times/min)		—	27	19	—	13

* Allowable regenerative frequency is the allowable frequency in the motor while accelerating and decelerating through a 0 → maximum motor speed → 0(r/min) cycle.

Note: Refer to 5.6 **Selecting a Regenerative Resistor** for more details on allowable regenerative energy and frequency.

8.5. Base-mounted Dimensional Drawings

8.5.1. XD-P3 to -02 (1-phase 200V, 30 to 200 W)

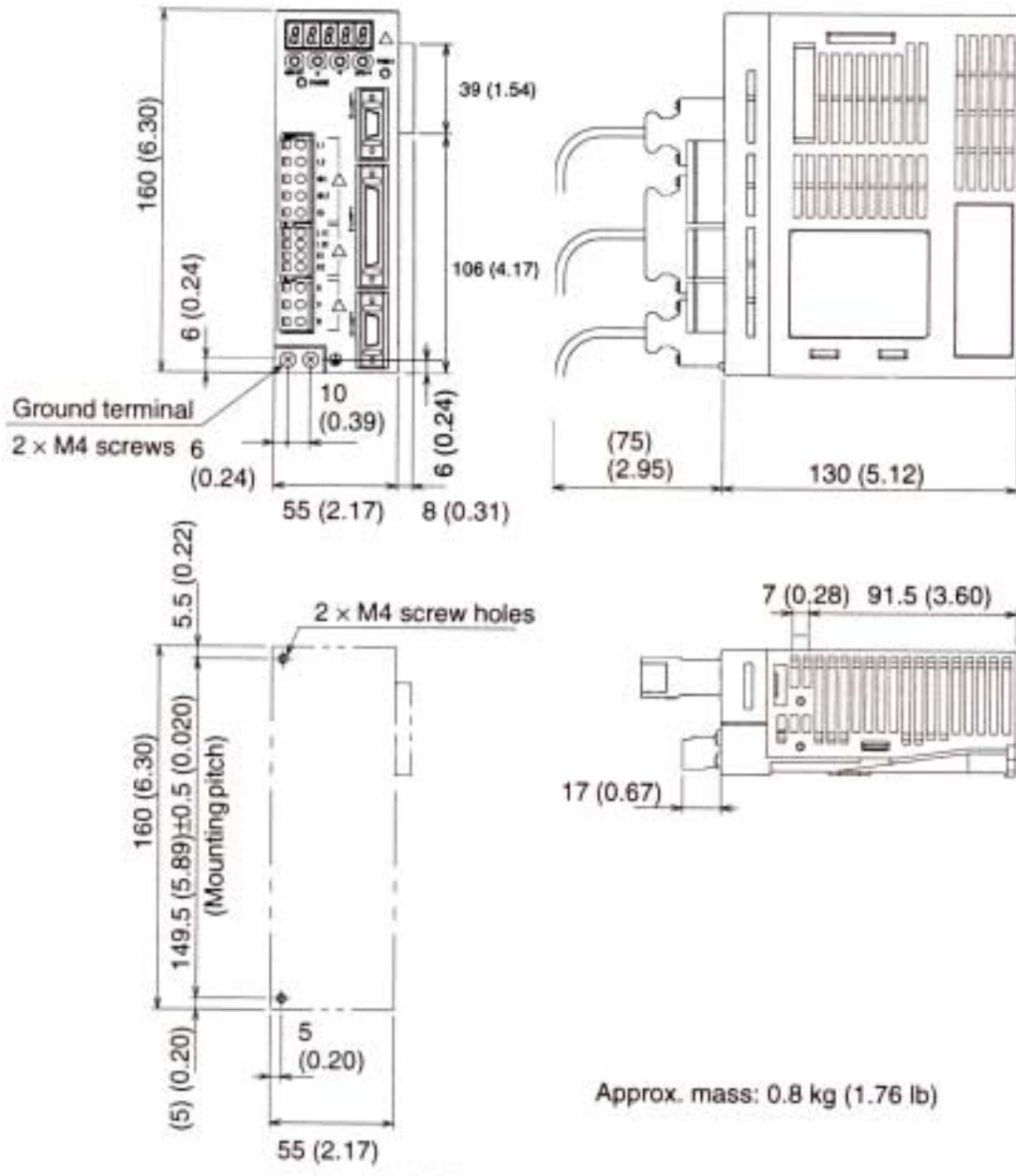

8.5.2. XD-04 (1-phase 200 V, 400 W)

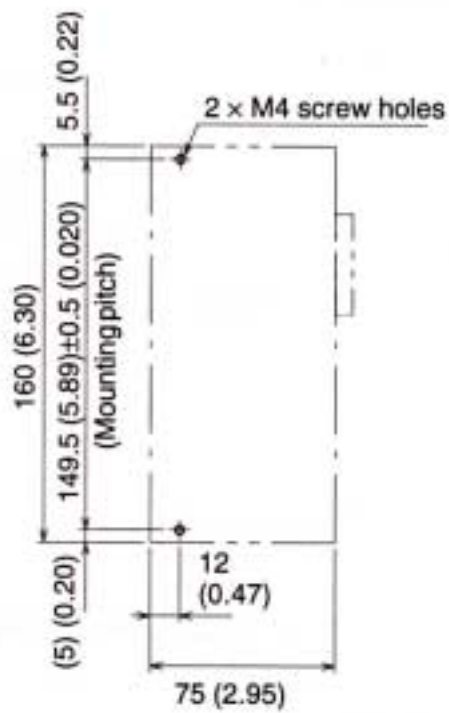
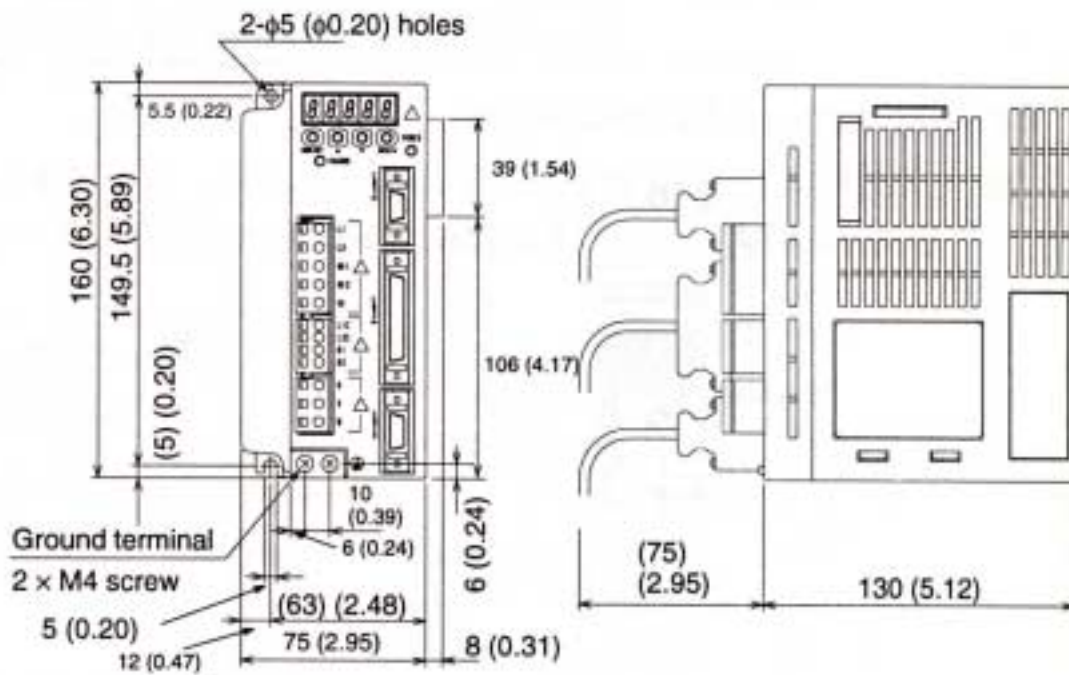

Mounting Hole Diagram

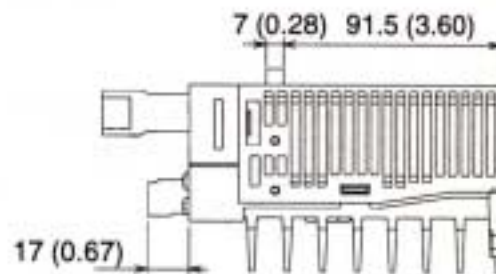

Approx. mass: 1.1 kg (2.43 lb)

8.5.3. XD-08 (1-phase 200V, 0.75kW) and XD-10 (3-phase 200V, 1.0kW)

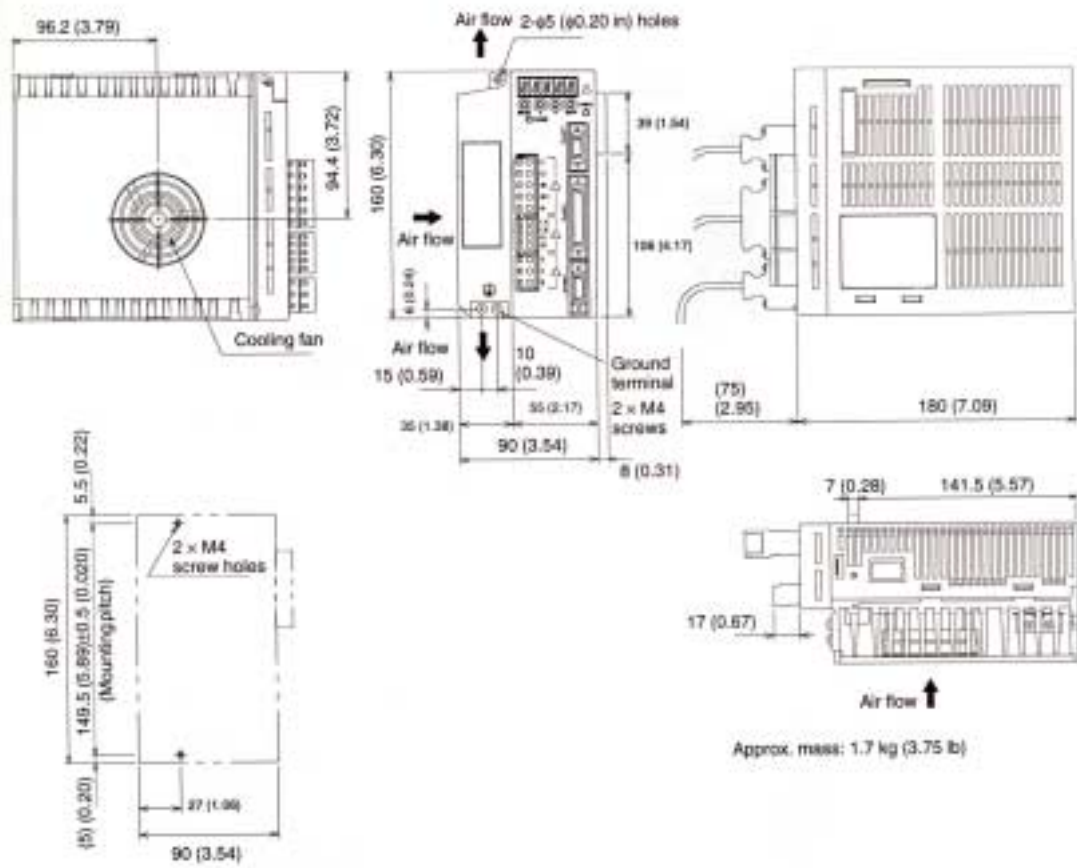

8.5.4. XD-05, 10, 15 (3-phase 400V, 0.5 to 1.5kW)

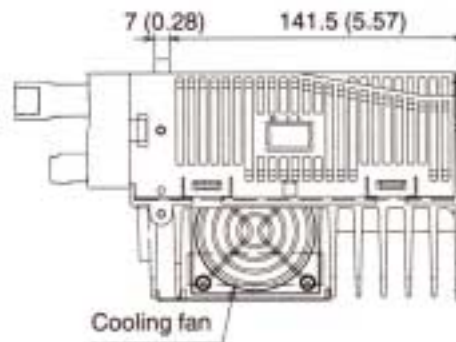
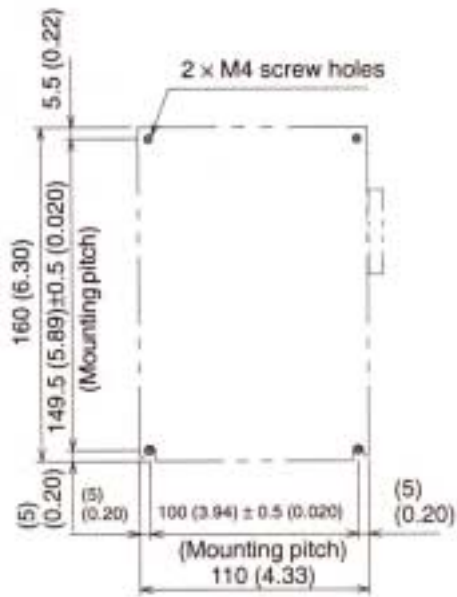
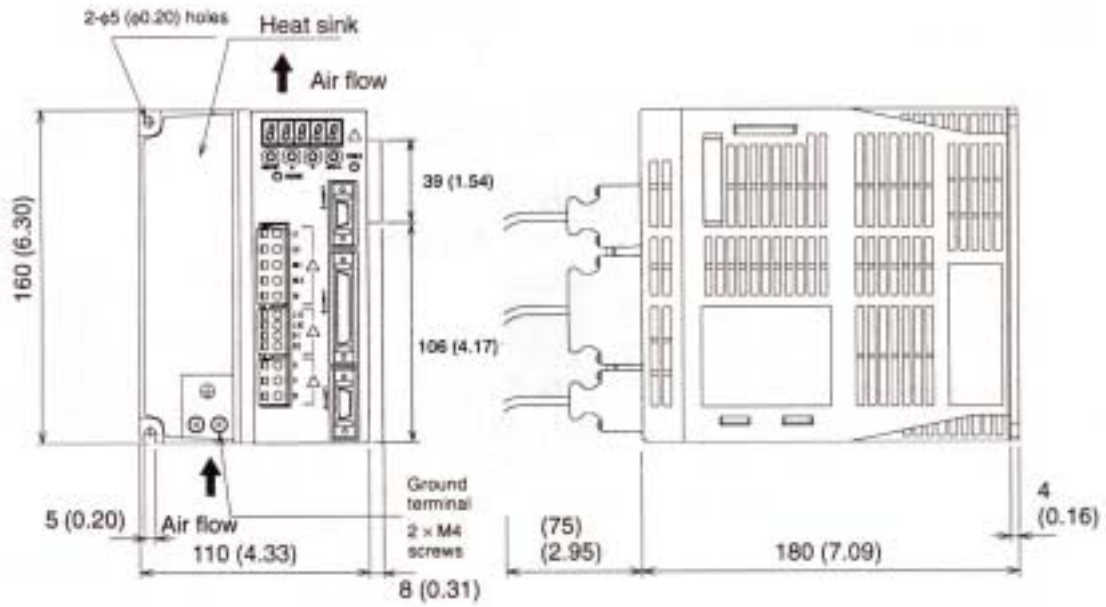

Approx. mass: 2.8 kg (6.17 lb)

8.5.5. XD-20, -30 (3-phase 200V,400V, 2.0 and 3.0 kW)

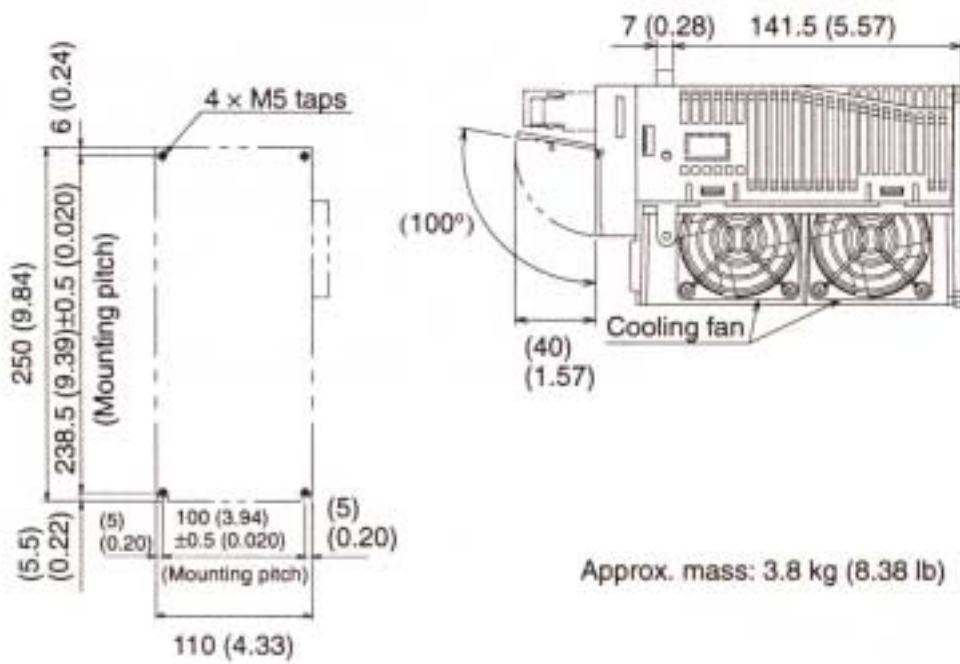
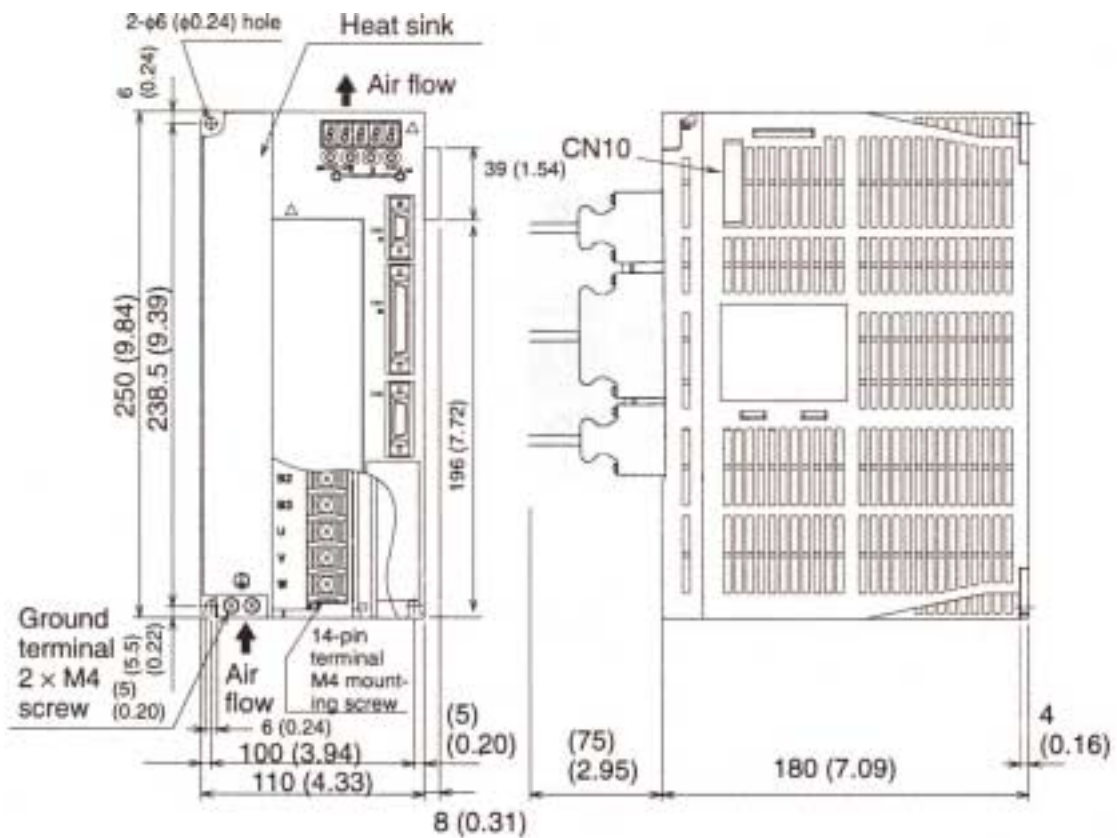

8.6. Rack-mounted Dimensional Drawings

8.6.1. XD-P3 to -02 (1-phase 200V, 30 to 200 W)

Units: mm(in)

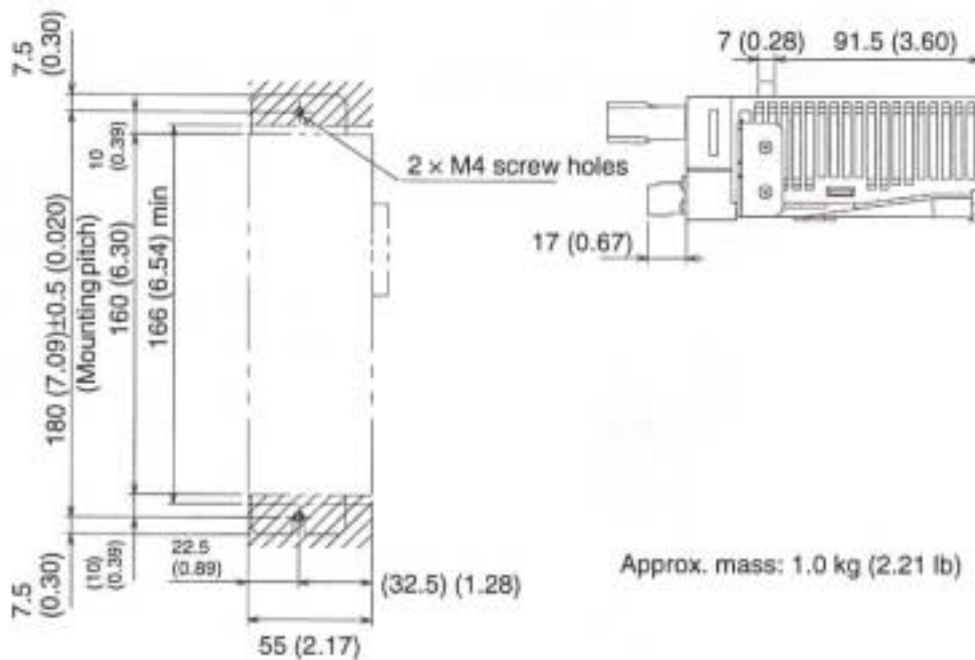
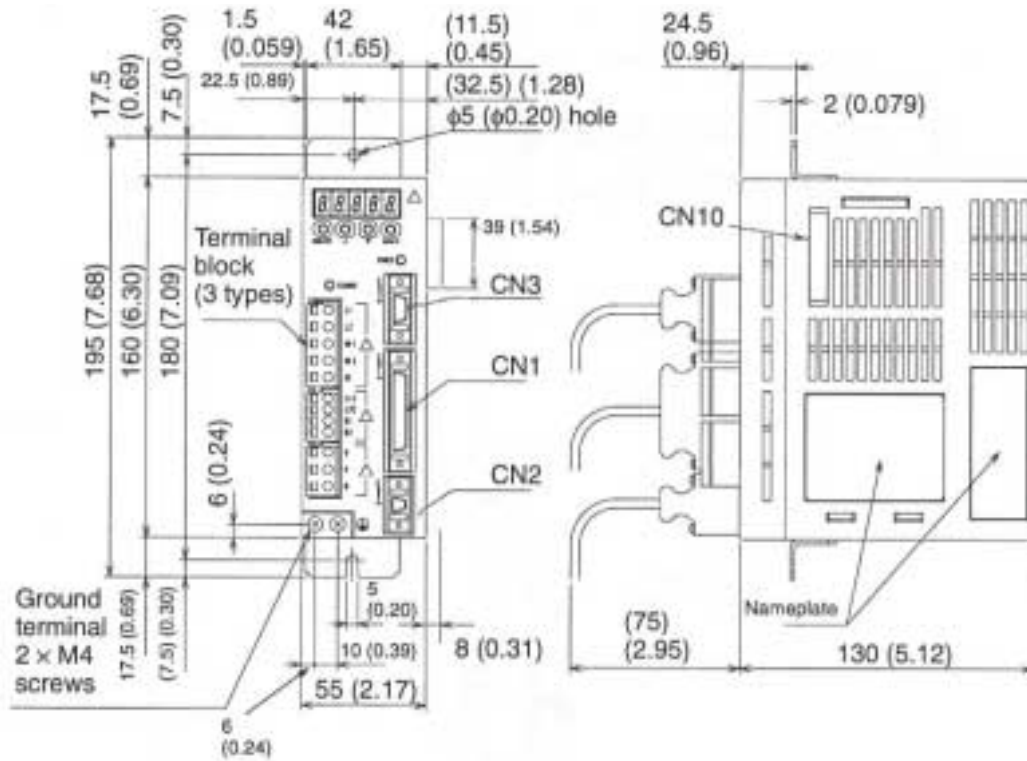

Mounting Hole Diagram

8.6.2. XD-04 (1-phase 200 V, 400 W)

Units: mm(in)

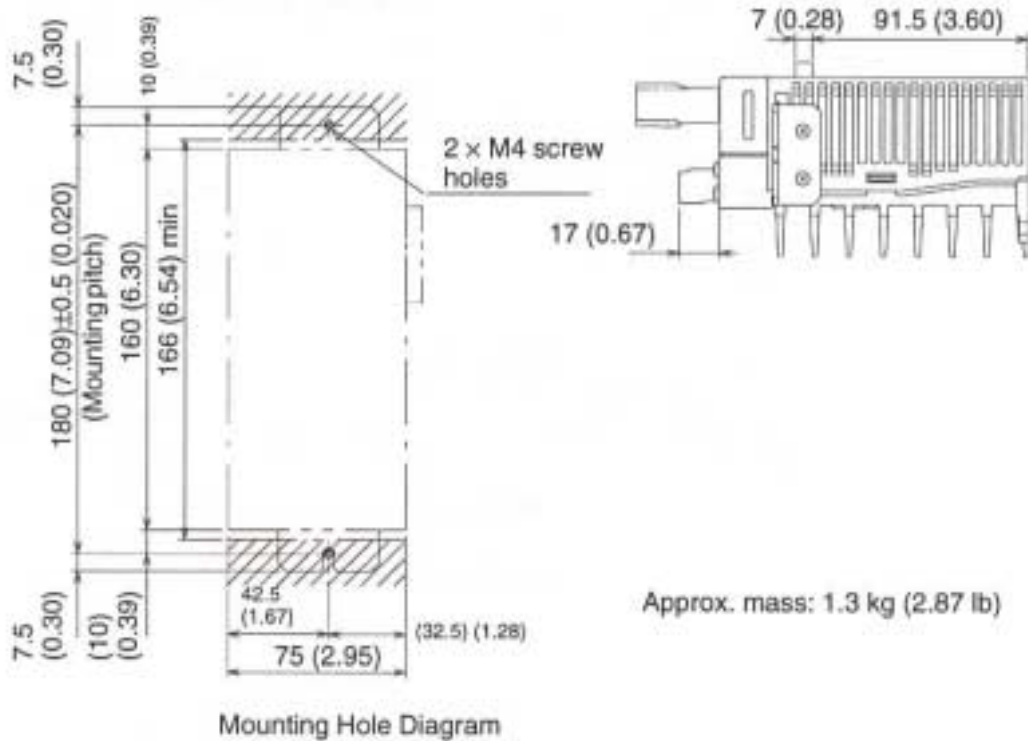
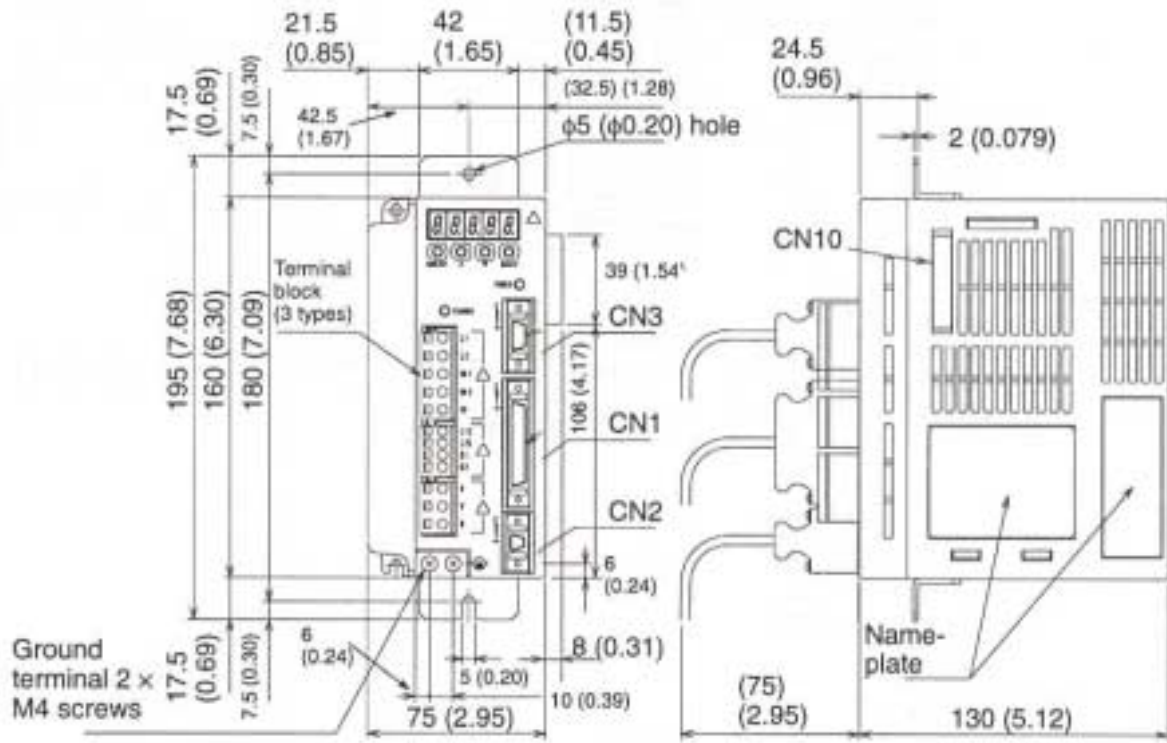

8.6.3. XD-08 (1-phase 200V, 0.75kW) and XD-10 (3-phase 200V, 1.0kW)

Units: mm(in)

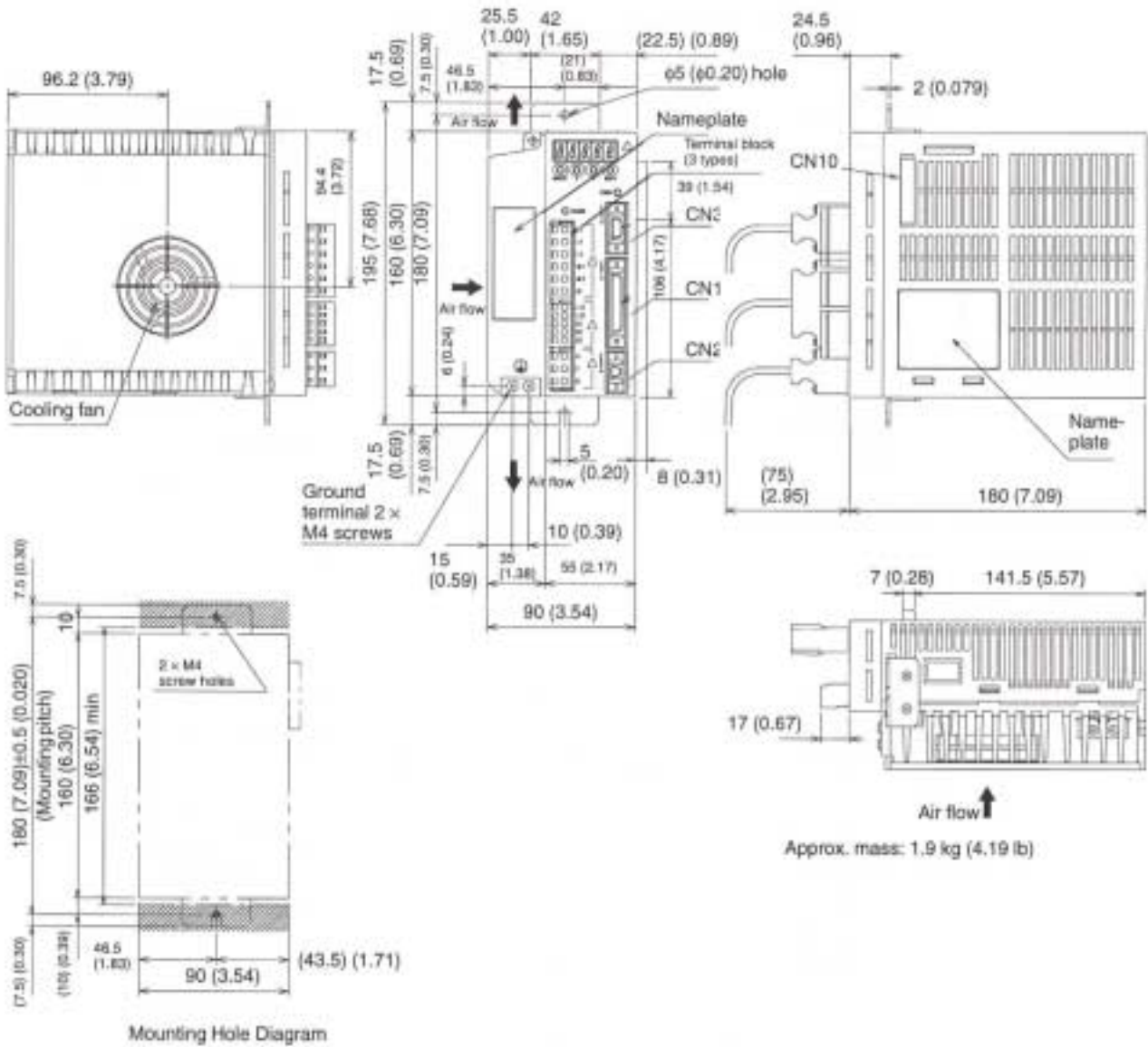

8.6.4. XD-05, 10, 15 (3-phase 400V, 0.5 to 1.5kW)

Units: mm(in)

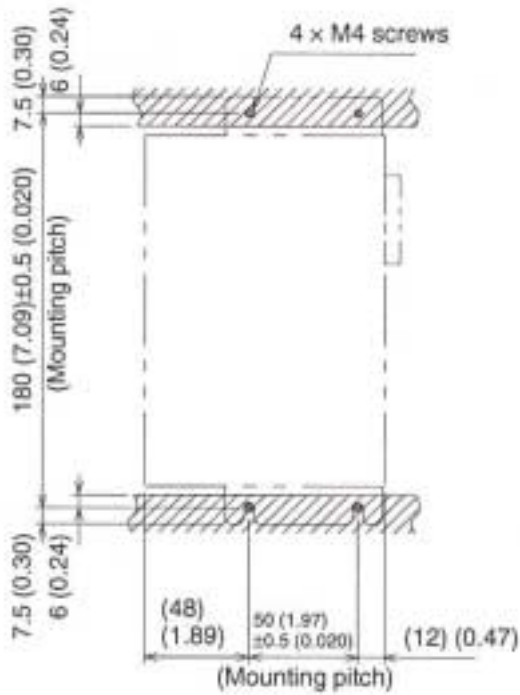
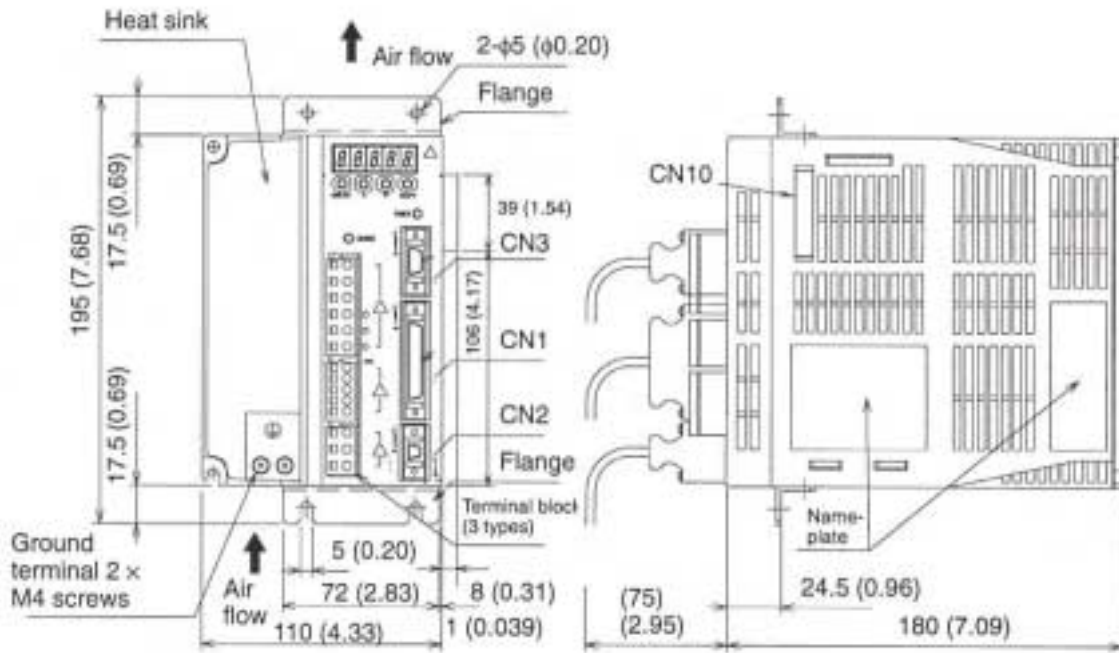

Mounting Hole Diagram

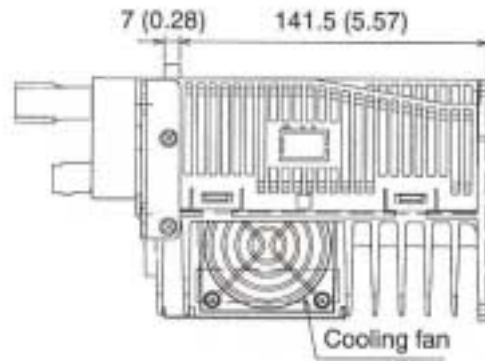

Approx. mass: 3.0 kg (6.61 lb)

8.6.5. XD-20, -30 (3-phase 200V,400V, 2.0 and 3.0 kW)

Units: mm(in)

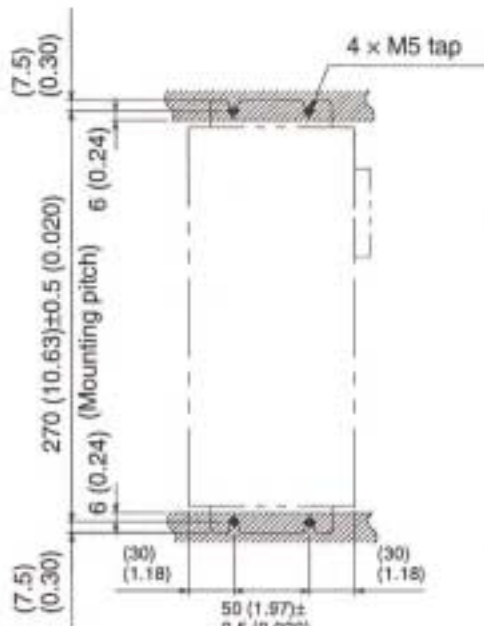
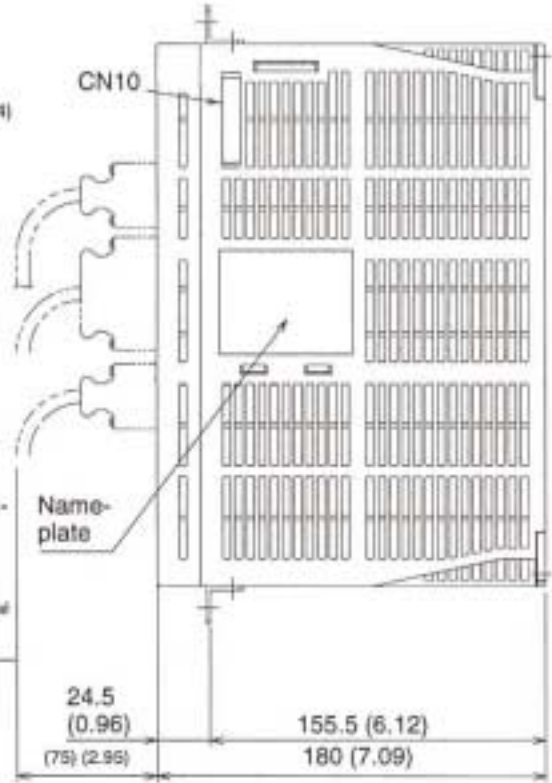
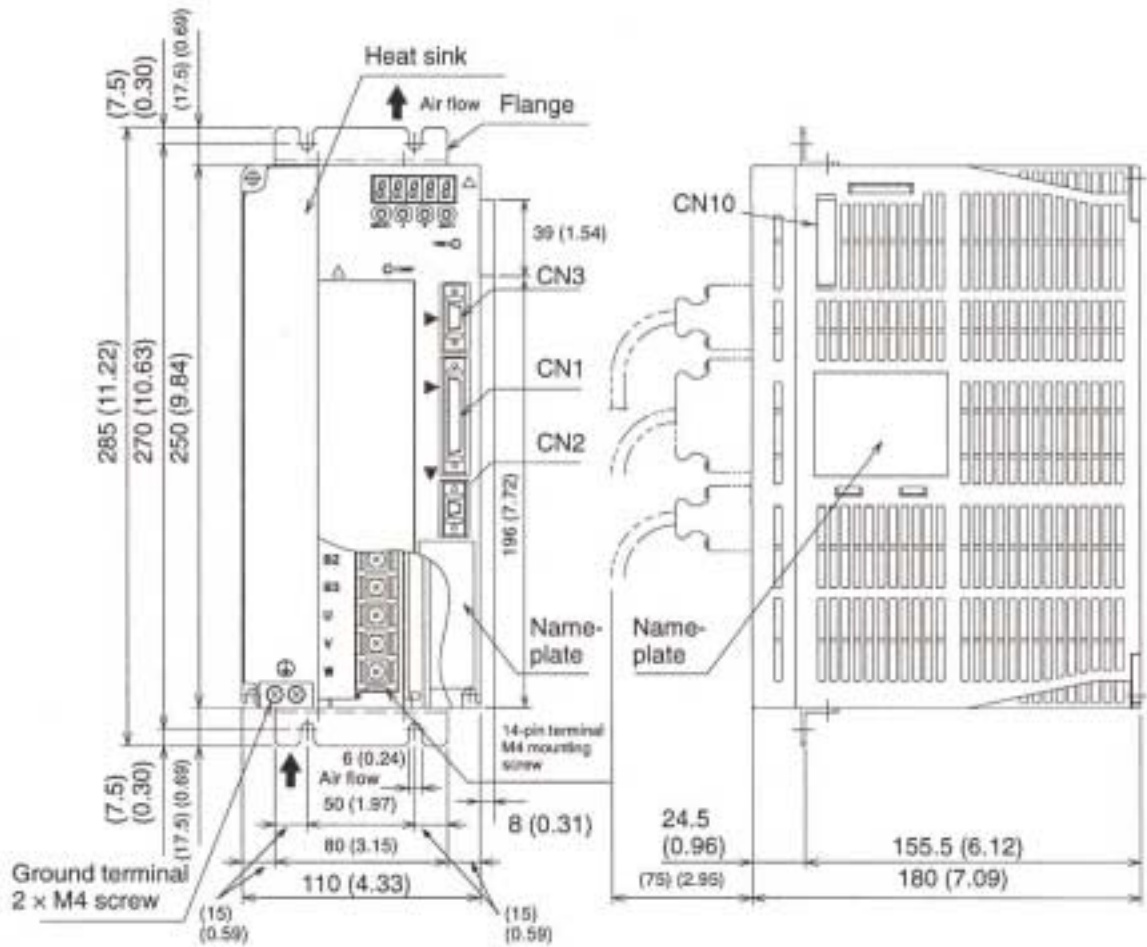

Mounting Hole Diagram

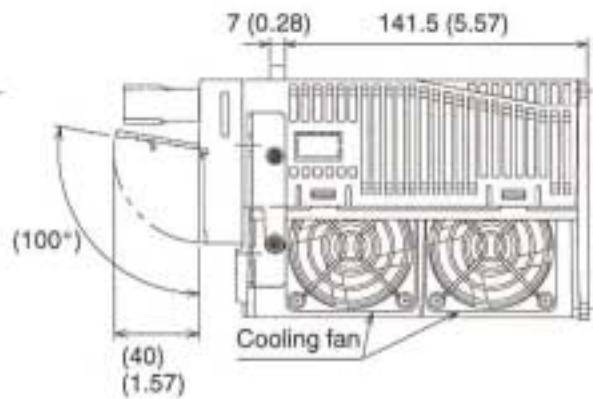

Approx. mass: 4.5 kg (9.92 lb)

9. Inspection, Maintenance, and Troubleshooting

This chapter describes the basic inspection and maintenance to be carried out by the user. In addition, troubleshooting procedures are described for problems, which generate an alarm display, and for problems, which result in no alarm display.

9.1.	XtraDrive Inspection and Maintenance	9-2
9.1.1.	Servomotor Inspection	9-2
9.1.2.	Servo Amplifier Inspection.....	9-2
9.1.3.	Replacing the Battery for the Absolute Encoder	9-3
9.2.	Troubleshooting	9-4
9.2.1.	Troubleshooting Problems with Alarm Displays.....	9-4
9.2.2.	Troubleshooting Problems with No Alarm Display	9-25
9.2.3.	Alarm Display Table.....	9-26
9.2.4.	Warning Displays.....	9-28

9.1. XtraDrive Inspection and Maintenance

This section describes the basic inspections and maintenance of servomotors and servo amplifiers and the procedures for replacing the battery for absolute encoders.

9.1.1. Servomotor Inspection

For inspection and maintenance of servomotors, follow the simple, daily inspection procedures in the following table.

The AC servomotors are brushless. Simple, daily inspection is sufficient under most conditions. The inspection and maintenance frequencies in the table are only guidelines. Increase or decrease the frequency to suit the operating conditions and environment.

IMPORTANT
<ul style="list-style-type: none"> • During inspection and maintenance, do not disassemble the servomotor. If disassembly of the servomotor is required, contact Yaskawa.

Servomotor Inspection

Action or Problem	Frequency	Procedure	Comments
Vibration and Noise	Daily	Touch and listen.	Levels higher than normal?
Exterior Dirt	According to degree of contamination	Clean with cloth or compressed air.	—
Insulation Resistance Measurement	At least every year	Disconnect servo amplifier and test insulation resistance at 500V. Must exceed 10MΩ*	Contact Yaskawa if the insulation resistance is below 10MΩ
Oil Seal Replacement	At least every 5000 hours	Remove servomotor from machine and replace oil seal.	Applies only to motors with oil seals.
Servomotor Overhaul	At least every 20000 hours or 5 years	Contact YET	The user should not disassemble and clean the servomotor.

* Measure across the servomotor FG and the U-phase, V-phase, or W-phase power line

9.1.2. Servo Amplifier Inspection

For inspection and maintenance of the servo amplifier, follow the inspection procedures in the table below. Perform inspection and maintenance at least once a year. Other routine inspections are not required.

Action or Problem	Frequency	Procedure	Comments
Clean interior and circuit boards	At least every year	Check for dust, dirt, and oil on the surfaces.	Clean with compressed air.
Loose screws	At least every year	Check for loose terminal block and connector screws.	Tighten any loose screws.
Defective parts in unit or on circuit boards	At least every year	Check for discoloration, damage or discontinuities due to heating.	Contact YET

■ Part Replacement Schedule

The following parts are subject to mechanical wear or deterioration over time. To avoid failure, replace these parts at the frequency indicated.

The parameters of any servo amplifiers overhauled by YET are reset to the default (standard factory) settings before shipping. Be sure to confirm that the parameters are set to the application's requirements before starting operation.

Part	Standard Lifespan	Replacement Method
Cooling fan	4 to 5 years	Replace with new part.
Smoothing capacitor	7 to 8 years	Test. Replace with a new part, if necessary.
Relays	—	Test. Replace if necessary.
Fuse	10 years	Replace with new part.
Aluminum electrolytic capacitor on circuit board	5 years	Test. Replace with new circuit board, if necessary.

Operating Conditions:

Ambient Temperature: Annual average of 30°C.

Load Factor: 80%, maximum.

Operation Rate: 20 hours/day, maximum.

9.1.3. Replacing the Battery for the Absolute Encoder

If the voltage of the battery for an absolute encoder drops to about 2.7V or less, an Absolute Encoder Battery Alarm (A. 83*) will occur in the servo amplifier. This alarm occurs when the servo amplifier receives a signal from the absolute encoder when the power to the servo amplifier is turned ON. Therefore, the servo amplifier will not give an alarm when the battery voltage drops below the minimum voltage level while the power is being supplied to the servo amplifier.

Refer to *C.9 Absolute Encoder Battery* for the battery type recommended for absolute encoders.

Replace the battery using the following procedure if the battery voltage drops below the minimum required battery voltage.

■ Battery Replacement Procedure

1. Replace the battery while the control power to the servo amplifier is ON.
2. After replacement, turn OFF the power of the servo amplifier in order to clear the Absolute Encoder Battery Alarm (A. 83).
3. Turn ON the power of the servo amplifier again and confirm that it operates properly.

Note: The absolute encoder data will be lost when the control power to the servo amplifier is turned OFF and the encoder cable is disconnected from the battery. If the data is lost, refer to *5.7.3 I. Absolute Encoder Setup* and follow the procedure to initialize the absolute encoder.

* Alarm A.83 is described in greater detail on page 9 - 14.

9.2. Troubleshooting

This section describes causes and remedies for problems, which generate an alarm display, and for problems, which result in no alarm display.

9.2.1. Troubleshooting Problems with Alarm Displays

Problems that occur in the servo drives are displayed on the panel operator as “A.□□” or “CPF□□”. Refer to the following sections to identify the cause of an alarm and the action to be taken.

Contact YET if the problem has not been solved after following the described procedures.

Note: “A.- -: Normal Operation”, is not an alarm.

■ A.02: Parameter Breakdown

Display and Outputs

Alarm Outputs			
Alarm Code Output			ALM Output
ALO1	ALO2	ALO3	
OFF	OFF	OFF	OFF

Note: OFF: Output transistor is OFF (alarm state).

Status and Remedy for Alarm

At power ON — A, B

Cause of the Problem		Solution
A	Power turned OFF during parameter writes. Alarm occurred at next power ON.	<ul style="list-style-type: none"> Initialize parameters using Fn005 then reenter settings. Replace the servo amplifier.
B	Circuit board (1PWB) defective.	Replace the servo amplifier.

■ A.03: Main Circuit Detection Error

Display and Outputs

Alarm Outputs			
Alarm Code Output			ALM Output
ALO1	ALO2	ALO3	
OFF	OFF	OFF	OFF

Note: OFF: Output transistor is OFF (alarm state).

Status and Remedy for Alarm

At power ON — A

Cause of the Problem		Solution
A	Circuit board (1PWB or 2PWB) defective.	Replace servo amplifier.

■ A.04: Parameter Setting Error

Display and Outputs

Alarm Outputs			
Alarm Code Output			ALM Output
ALO1	ALO2	ALO3	
OFF	OFF	OFF	OFF

Note: OFF: Output transistor is OFF (alarm state).

Status and Remedy for Alarm

At power ON — A,B

	Cause of the Problem	Solution
A	An out-of-range parameter was previously set or loaded	Reset all parameters in the range. Otherwise, reload the correct parameter.
B	Circuit board (1PWB) is defective.	Replace the servo amplifier.

■ A.05: Servomotor and Amplifier Combination Error

Display and Outputs

Alarm Outputs			
Alarm Code Output			ALM Output
ALO1	ALO2	ALO3	
OFF	OFF	OFF	OFF

Note: OFF: Output transistor is OFF (alarm state).

Status and Remedy for Alarm

At power ON — A,B

	Cause of the Problem	Solution
A	The range of servomotor capacities that can be combined has been exceeded.	Replace the servomotor so that an acceptable combination is achieved.
B	Encoder parameters have not been written properly.	Replace the servomotor.

■ A.10: Overcurrent or Heat Sink Overheated

Display and Outputs

Alarm Outputs			
Alarm Code Output			ALM Output
ALO1	ALO2	ALO3	
ON	OFF	OFF	OFF

Note: OFF: Output transistor is OFF (alarm state).
 ON: Output transistor is ON.

Status and Remedy for Alarm

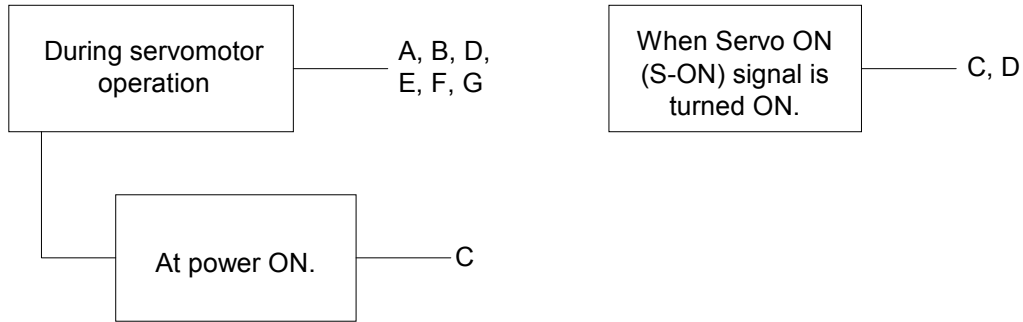

Cause of the Problem		Solution
A	Shorted wiring between servo amplifier and servomotor.	Check and correct wiring.
B	Shorted servomotor U, V, or W phase.	Replace servomotor.
C	Defective circuit board (1PWB) Defective power transistor.	Replace servo amplifier.
D	Defective current feedback circuit, power transistor, DB circuit, or circuit board.	Replace servo amplifier.
E	Ambient temperature of the servo amplifier greater than 55°C.	Alter conditions so that the ambient temperature is below 55°C.
F	Inadequate airflow around the heat sink.	Providing sufficient space as specified.
G	Fan stopped.	Replace servo amplifier.
H	Servo amplifier is operating under an overload.	Reduce load.

Note: Problems E to H can occur in a servo amplifier with a capacity of 1.5 to 5kW, and all 400V models.

■ A.30: Regenerative Error Detected

Display and Outputs

Alarm Outputs			
Alarm Code Output			ALM Output
ALO1	ALO2	ALO3	
ON	ON	OFF	OFF

Note: OFF: Output transistor is OFF (alarm state).
ON: Output transistor is ON.

Status and Remedy for Alarm

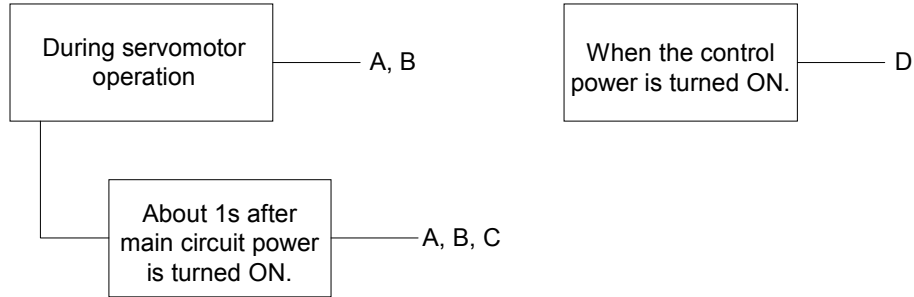

Cause of the Problem		Solution
A	Malfunctioning regenerative transistor.	Replace servo amplifier.
B	Regenerative resistor is open.	Replace servo amplifier or regenerative resistor.
C	Disconnected regenerative unit (for an external regenerative resistor).	Check the wiring of the external regenerative resistor.
D	Defective servo amplifier.	Replace servo amplifier.

■ A.32: Regenerative Overload

Display and Outputs

Alarm Outputs			
Alarm Code Output			ALM Output
ALO1	ALO2	ALO3	
ON	ON	OFF	OFF

Note: OFF: Output transistor is OFF (alarm state).
ON: Output transistor is ON.

Status and Remedy for Alarm

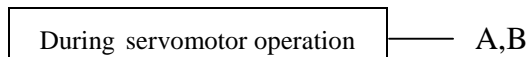

Cause of the Problem		Solution
A	Regenerative power exceeds the limit.	Use an external regenerative resistor that matches the regenerative power capacity.
B	Alarm occurs although an external regenerative resistor is used and the temperature rise of the regenerative resistor is small.	Correct parameter Pn600.

■ **A.40: Main Circuit DC Voltage Error Detected: Overvoltage**

Display and Outputs

Alarm Outputs			
Alarm Code Output			ALM Output
ALO1	ALO2	ALO3	
OFF	OFF	ON	OFF

Note: OFF: Output transistor is OFF (alarm state).
 ON: Output transistor is ON.

Status and Remedy for Alarm

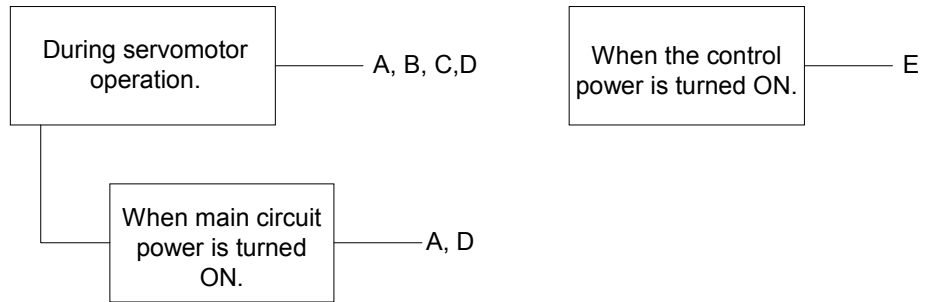

Cause of the Problem		Solution
A	Power supply voltage is not within the range of specifications.	Check power supply.
B	Load exceeds capacity of the regenerative unit.	Check specifications of load inertia and overhanging load.
C	Malfunctioning regenerative transistor.	Replace servo amplifier.
D	Defective rectifying diode.	
E	Defective servo amplifier.	

■ A.41: Main Circuit DC Voltage Error Detected: Undervoltage

Display and Outputs

Alarm Outputs			
Alarm Code Output			ALM Output
ALO1	ALO2	ALO3	
OFF	OFF	ON	OFF

Note: OFF: Output transistor is OFF (alarm state).
ON: Output transistor is ON.

Status and Remedy for Alarm

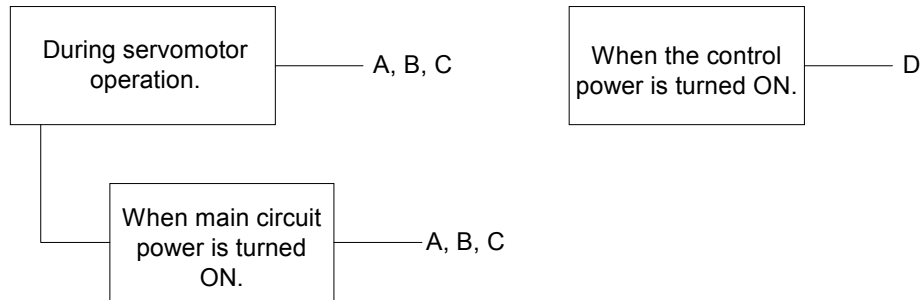

Cause of the Problem		Solution
A	The power supply voltage exceeds specified range.	Check power supply voltage.
B	Fuse blown.	Replace servo amplifier.
C	Defective rectifying diode.	
D	Defective servo amplifier.	

■ A.51: Overspeed

Display and Outputs

Alarm Outputs			
Alarm Code Output			ALM Output
ALO1	ALO2	ALO3	
ON	OFF	ON	OFF

Note: OFF: Output transistor is OFF (alarm state).
ON: Output transistor is ON.

Status and Remedy for Alarm

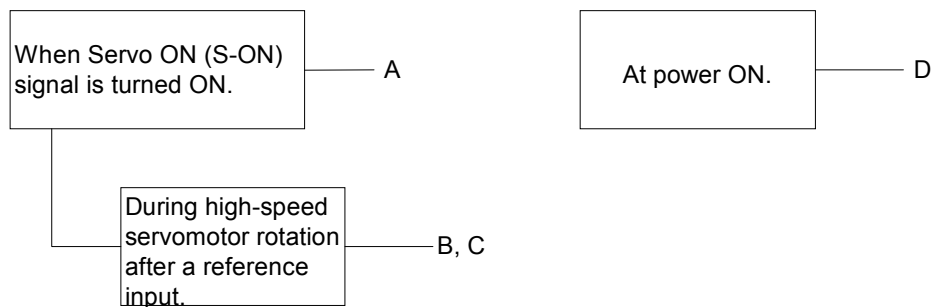

Cause of the Problem		Solution
A	Incorrect servomotor wiring.	Check and correct wiring. (Check for U-, V-, and W-phase wiring errors.)
B	Position or speed reference input is too large.	Lower the reference input values.
C	Incorrect reference input gain settings.	Check and correct parameter settings.
D	Defective circuit board (1PWB).	Replace servo amplifier.

■ **A.71, A.72**

A.71: Overload: High Load

A.72: Overload: Low Load.

The alarm output, status, and remedy for A.71 are the same as for A.72.

Display and Outputs

Alarm Outputs			
Alarm Code Output			ALM Output
ALO1	ALO2	ALO3	
ON	ON	ON	OFF

Note: OFF: Output transistor is OFF (alarm state).
 ON: Output transistor is ON.

Status and Remedy for Alarm

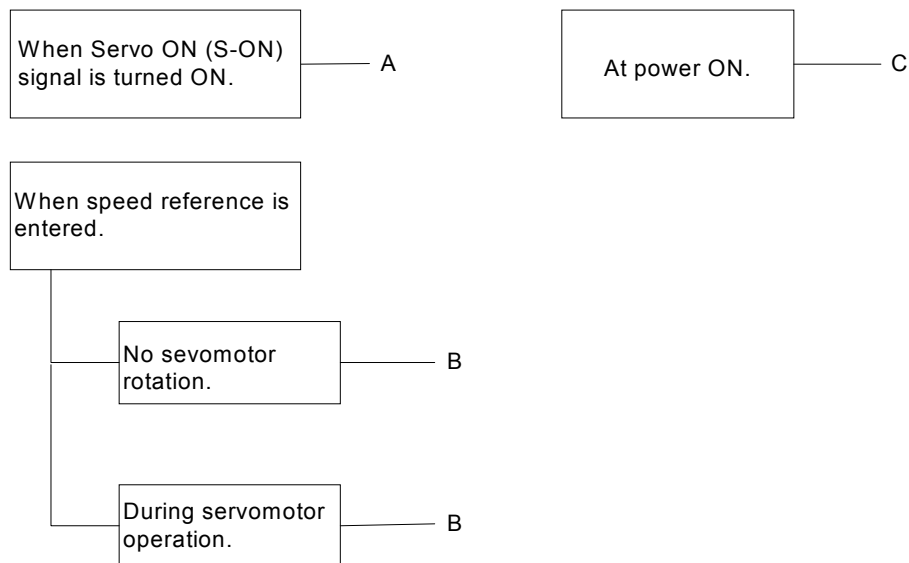

Cause of the Problem		Solution
A	Incorrect or disconnected servomotor wiring.	Check wiring and connectors at the servomotor.
B	Load greatly exceeds rated torque.	Reduce load torque and inertia. Otherwise, replace with a larger capacity servomotor.
C	Defective circuit board (1PWB).	Replace servo amplifier.

Overload Characteristics

Servo amplifiers have a built-in overload protection function that protects the servo amplifiers and servo motors from overload. Allowable power for the servo amplifiers is limited by the overload protective function, as shown in the figure below.

The overload detection level is set under hot start conditions at a servomotor ambient temperature of 40°C.

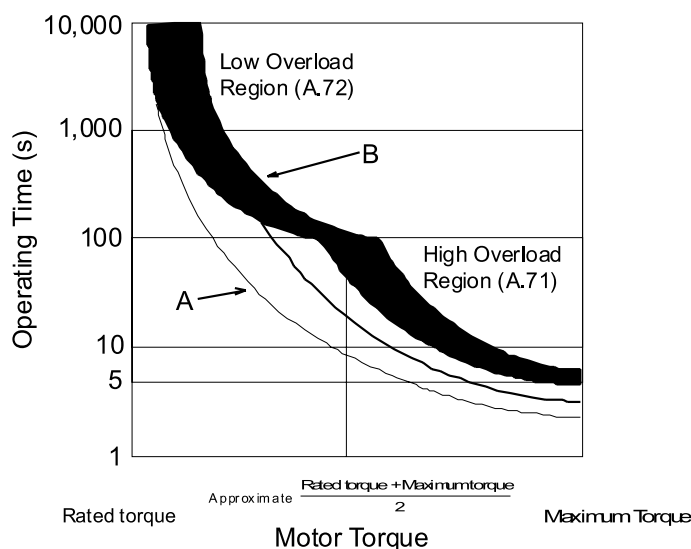

Note: The overload protection characteristics of A and B in the figure are applicable when the servo amplifier is combined with one of the following servomotors:
 A: SGMAH or SGMPPH servomotor with a maximum capacity of 400W, 100V and 200V only.
 B: Other servomotors similar to the SGMAH, SGMPPH, SGMGH, SGMSSH, and SGMUH.

■ A.73: Dynamic Brake Overload

Display and Outputs

Alarm Outputs			
Alarm Code Output			ALM Output
ALO1	ALO2	ALO3	
ON	ON	ON	OFF

Note: OFF: Output transistor is OFF (alarm state).
 ON: Output transistor is ON.

Status and Remedy for Alarm



Cause of the Problem		Solution
A	The product of the square of rotational motor speed, the combined inertia of the motor, and load (rotation energy) exceeds the capacity of the dynamic brake resistor built into servo amplifier.	<ul style="list-style-type: none"> Reduce the rotational speed. Decrease the load inertia. Minimize use of the dynamic brake.
B	Defective circuit board (1PWB).	Replace servo amplifier.

■ A.74: Overload of Surge Current Limit Resistor

Display and Outputs

Alarm Outputs			
Alarm Code Output			ALM Output
ALO1	ALO2	ALO3	
ON	ON	ON	OFF

Note: OFF: Output transistor is OFF (alarm state).
ON: Output transistor is ON.

Status and Remedy for Alarm



Cause of the Problem		Solution
A	Frequently turning the main circuit power ON/OFF.	Do not repeatedly turn ON/OFF the main circuit power.
B	Defective circuit board (1PWB).	Replace servo amplifier.

■ A.7A: Heat Sink Overheated

Heat sink temperature exceeds 100°C.

Display and Outputs

Alarm Outputs			
Alarm Code Output			ALM Output
ALO1	ALO2	ALO3	
ON	ON	ON	OFF

Note: OFF: Output transistor is OFF (alarm state).
ON: Output transistor is ON.

Status and Remedy for Alarm

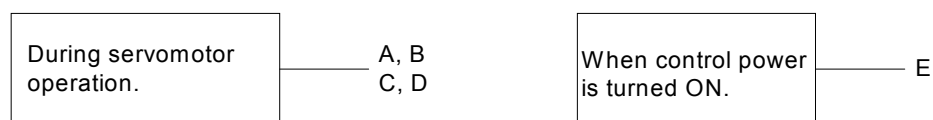

Cause of the Problem		Solution
A	The ambient temperature of the servo amplifier exceeds 55°C.	Alter conditions so that the ambient temperature goes below 55°C.
B	Inadequate air flow around the heat sink .	Provide sufficient space as specified.
C	Fan stopped.	Replace servo amplifier.
D	Servo amplifier is operating under overload.	Reduce load.
E	Defective servo amplifier.	Replace servo amplifier.

Note: Larger servo amplifiers (1.5kW., or larger) will display alarm A.10 if the heat sink overheats.

■ A.81: Absolute Encoder Backup Power Supply Error

Display and Outputs

Alarm Outputs			
Alarm Code Output			ALM Output
ALO1	ALO2	ALO3	
OFF	OFF	OFF	OFF

Note: OFF: Output transistor is OFF (alarm state).

Status and Remedy for Alarm

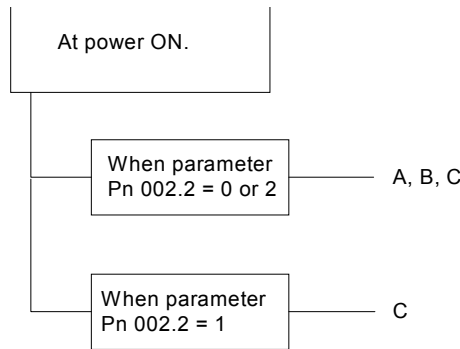

Cause of the Problem		Solution
A	The following power supplies to the absolute encoder both failed: <ul style="list-style-type: none"> +5V supply Battery power 	Follow absolute encoder setup procedure.
B	Absolute encoder malfunctioned.	Replace servomotor.
C	Defective circuit board (1PWB).	Replace servo amplifier.

■ A.82: Encoder Checksum Error

Display and Outputs

Alarm Outputs			
Alarm Code Output			ALM Output
ALO1	ALO2	ALO3	
OFF	OFF	OFF	OFF

Note: OFF: Output transistor is OFF (alarm state).

Status and Remedy for Alarm

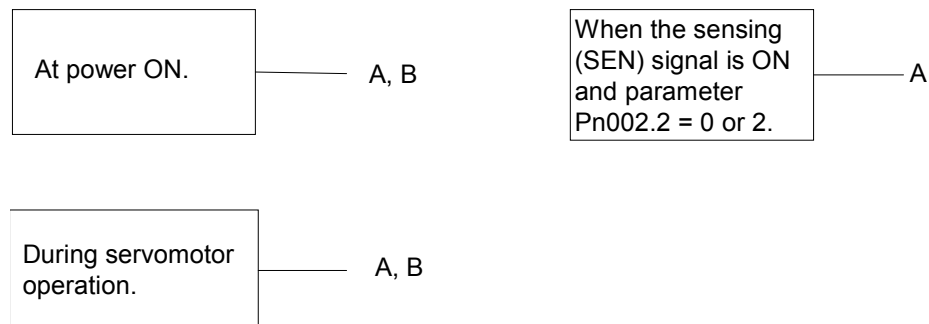

Cause of the Problem		Solution
A	Error during encoder memory check.	<ul style="list-style-type: none"> Follow absolute encoder setup procedure. Replace servomotor if error occurs frequently.
B	Defective circuit board (1PWB).	Replace servo amplifier.

■ A.83: Absolute Encoder Battery Error

Display and Outputs

Alarm Outputs			
Alarm Code Output			ALM Output
ALO1	ALO2	ALO3	
OFF	OFF	OFF	OFF

Note: OFF: Output transistor is OFF (alarm state).

Status and Remedy for Alarm

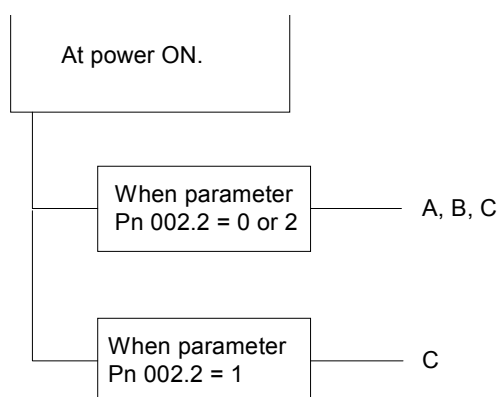

Cause of the Problem		Solution
A	<ul style="list-style-type: none"> Disconnected battery. Defective battery connection. 	Check and correct battery connection.
B	Battery voltage below specified value. Specified value: 2.7V.	Install a new battery while the control power to the servo amplifier is ON. After replacement, cycle the power OFF and ON again.
C	Defective circuit board (1PWB).	Replace servo amplifier.*

* The replacement procedure is described in *Section 9.1.3 Replacing the Battery for the Absolute Encoder*

Note: No alarm will occur at the servo amplifier if the battery error occurs during operation.

■ **A.84: Absolute Encoder Data Error**

Display and Outputs

Alarm Outputs			
Alarm Code Output			ALM Output
ALO1	ALO2	ALO3	
OFF	OFF	OFF	OFF

Note: OFF: Output transistor is OFF (alarm state).

Status and Remedy for Alarm

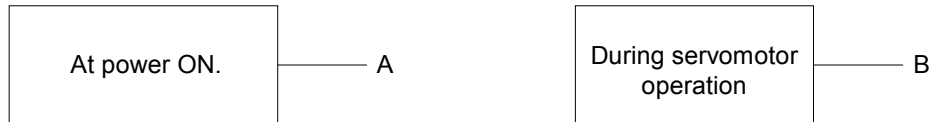

Cause of the Problem		Solution
A	Malfunctioning absolute encoder.	Replace servomotor if error occurs frequently.
B	Operational error in encoder caused by external noise	Check and correct wiring around the encoder, (grounding of servomotor, separation of encoder and power cables, insertion of toroidal cores onto cables to reduce noise, etc.)

■ **A.85: Absolute Encoder Overspeed**

Display and Outputs

Alarm Outputs			
Alarm Code Output			ALM Output
ALO1	ALO2	ALO3	
OFF	OFF	OFF	OFF

Note: OFF: Output transistor is OFF (alarm state).

Status and Remedy for Alarm

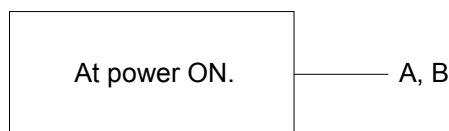

Cause of the Problem		Solution
A	Absolute encoder turned ON at motor speed exceeding 200rpm.	Turn ON power supply with the servomotor stopped.
B	Defective circuit board (1PWB).	Replace servo amplifier.

■ **A.86: Encoder Overheated**

Display and Outputs

Alarm Outputs			
Alarm Code Output			ALM Output
ALO1	ALO2	ALO3	
OFF	OFF	OFF	OFF

Note: OFF: Output transistor is OFF (alarm state).

Status and Remedy for Alarm

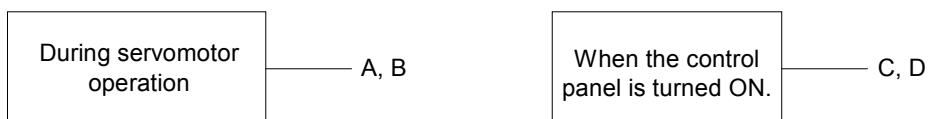

Cause of the Problem		Solution
A	The ambient temperature of the servomotor is high.	Alter conditions so that the ambient temperature goes below 40°C.
B	Servomotor is operating under overload.	Reduce load.
C	Defective circuit board (1PWB).	Replace servo amplifier.
D	Encoder defective.	Replace servo amplifier.

■ **A.b1, A.b2**

A.b1: Reference Speed Input Read Error

A.b2: Reference Torque Input Read Error

The alarm output, status, and remedy for A.b1 are the same as for A.b2.

Display and Outputs

Alarm Outputs			
Alarm Code Output			ALM Output
ALO1	ALO2	ALO3	
OFF	OFF	OFF	OFF

Note: OFF: Output transistor is OFF (alarm state).

Status and Remedy for Alarm



Cause of the Problem		Solution
A	Error in reference read-in unit (A/D Converter, etc.).	Reset alarm and restart operation.
B	Faulty reference read-in unit (A/D Converter, etc.).	Replace servo amplifier.
C	Defective circuit board (1PWB).	Replace servo amplifier.

■ A.C1: Servo Run Away

Display and Outputs

Alarm Outputs			
Alarm Code Output			ALM Output
ALO1	ALO2	ALO3	
ON	OFF	ON	OFF

Note: OFF: Output transistor is OFF (alarm state).
 ON: Output transistor is ON.

Status and Remedy for Alarm

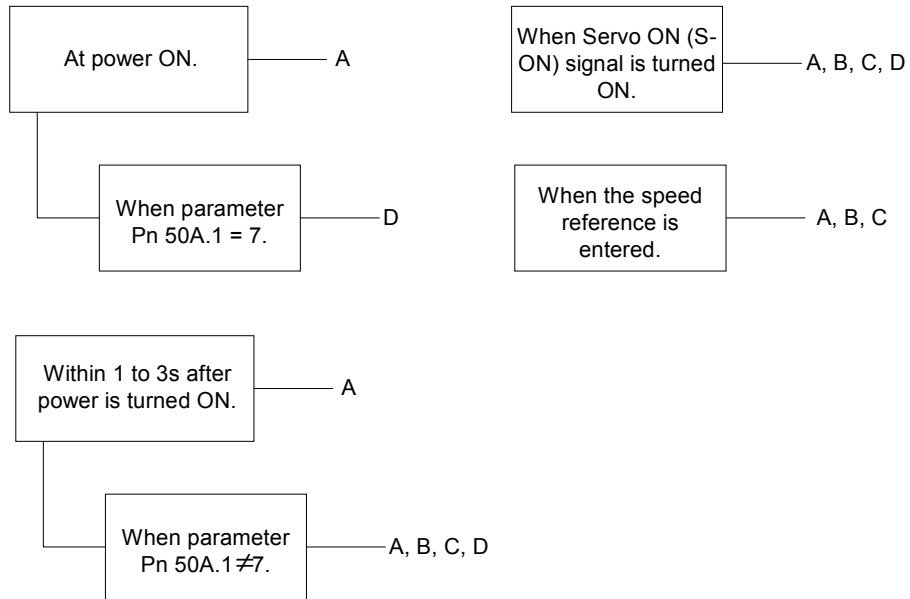

Cause of the Problem		Solution
A	Incorrect or disconnected servomotor wiring.	Check wiring and connectors at the servomotor.
B	Incorrect or disconnected encoder wiring.	Check wiring and connectors at the encoder.
C	Defective encoder.	Replace servomotor.
D	Defective circuit board (1PWB).	Replace servo amplifier.

■ A.C2: Commutation (Phase Finding) Error

Display and Outputs

Alarm Outputs			
Alarm Code Output			ALM Output
ALO1	ALO2	ALO3	
ON	OFF	ON	OFF

Note: OFF: Output transistor is OFF (alarm state).

Status and Remedy for Alarm

At first motor on sequence after power-up, using motor with A quad B encoder	- A, B ,C
--	-----------

Cause of the Problem		Solution
A	Motor parameters are faulty	Ask your local distributor for a new parameters file.
B	The initial value of Pn191.0 (phase order) is not correct	Set Pn191.0 to 0. (The XtraDrive will automatically find the right phase order and update this parameter value).
C	Undesired motor motion was detected when the motor was turned on for the first time after power-up	Before turning servo on, be sure that there is no mechanical movements/vibrations

■ A.C8: Absolute Encoder Clear Error and Multi-turn Limit Setting Error

Display and Outputs

Alarm Outputs			
Alarm Code Output			ALM Output
ALO1	ALO2	ALO3	
ON	OFF	ON	OFF

Note: OFF: Output transistor is OFF (alarm state).
ON: Output transistor is ON.

Status and Remedy for Alarm

At power ON.	— A, B	When resetting the multi-turn clear encoder alarm.	— A, B
--------------	--------	--	--------

Cause of the Problem		Solution
A	Encoder defective.	Replace servomotor.
B	Servo amplifier defective.	Replace servo amplifier.

■ A.C9: Encoder Communications Error

Display and Outputs

Alarm Outputs			
Alarm Code Output			ALM Output
ALO1	ALO2	ALO3	
ON	OFF	ON	OFF

Note: OFF: Output transistor is OFF (alarm state).
ON: Output transistor is ON.

Status and Remedy for Alarm

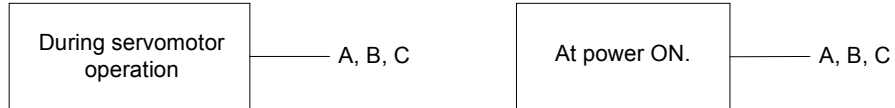

Cause of the Problem		Solution
A	Incorrect or disconnected encoder wiring.	Check wiring and connectors at the encoder.
B	Defective encoder.	Replace servomotor.
C	Defective servo amplifier.	Replace servo amplifier.

■ A.CA: Encoder Parameter Error

Display and Outputs

Alarm Outputs			
Alarm Code Output			ALM Output
ALO1	ALO2	ALO3	
ON	OFF	ON	OFF

Note: OFF: Output transistor is OFF (alarm state).
ON: Output transistor is ON.

Status and Remedy for Alarm

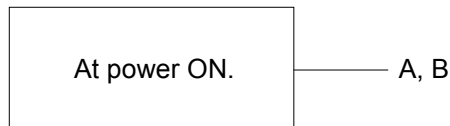

Cause of the Problem		Solution
A	Defective encoder.	Replace servomotor.
B	Defective servo amplifier.	Replace servo amplifier.

■ A.Cb: Encoder Echoback Error

Display and Outputs

Alarm Outputs			
Alarm Code Output			ALM Output
ALO1	ALO2	ALO3	
ON	OFF	ON	OFF

Note: OFF: Output transistor is OFF (alarm state).
ON: Output transistor is ON.

Status and Remedy for Alarm

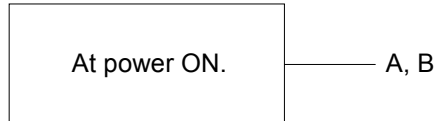

Cause of the Problem		Solution
A	Incorrect or disconnected encoder wiring.	Check wiring and connectors at encoder.
B	Defective encoder.	Replace servomotor.
C	Defective servo amplifier.	Replace servo amplifier.

■ A.CC: Multi-turn Limit Disagreement Alarm

Display and Outputs

Alarm Outputs			
Alarm Code Output			ALM Output
ALO1	ALO2	ALO3	
ON	OFF	ON	OFF

Note: OFF: Output transistor is OFF (alarm state).
ON: Output transistor is ON.

Status and Remedy for Alarm

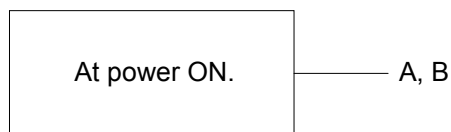

Cause of the Problem		Solution
A	Incorrectly set Multi-Turn Limit Setting parameter (Pn205) in the servo amplifier.	Change the value in parameter Pn205.
B	No Multi-Turn Limit value set in the encoder.	First verify that the Multi-Turn Limit Setting parameter (Pn205) is set correctly in the servo amplifier. While in the active alarm state, change the setting in the encoder Multi-Turn Limit Setting parameter (Pn205) using function Fn013.

■ **A.d0: Position Error Pulse Overflow**

Display and Outputs

Alarm Outputs			
Alarm Code Output			ALM Output
ALO1	ALO2	ALO3	
ON	ON	OFF	OFF

Note: OFF: Output transistor is OFF (alarm state).
 ON: Output transistor is ON.

Status and Remedy for Alarm

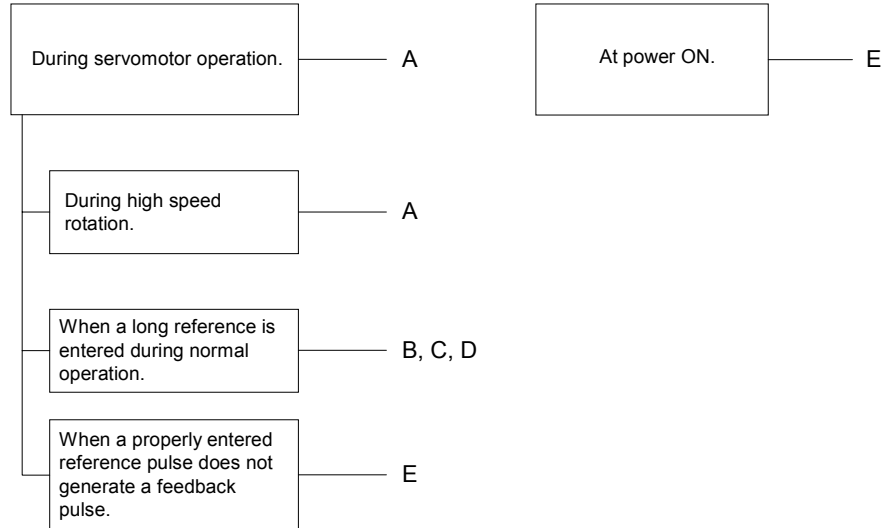

	Cause of the Problem	Solution
A	Servomotor wiring incorrect or poor connection	Check wiring and connectors at encoder.
B	Servo amplifier was not correctly adjusted.	Increase speed loop gain (Pn100) and position loop gain (Pn102).
C	Motor load was excessive.	Reduce load torque or inertia. If problem persists, replace with a larger capacity motor.
D	Position reference pulse frequency was too high.	<ul style="list-style-type: none"> • Increase or decrease reference pulse frequency. • Add smoothing function. • Correct electronic gear ratio.
E	Circuit board (1PWB) defective.	Replace servo amplifier.

■ A.E7: Option Unit Detection Error

A.E7 occurs the first time the SGDh amplifier is used after disconnecting an option unit. This alarm cannot be cleared with an alarm reset; instead, clear it with function Fn014.

Display and Outputs

Alarm Outputs			
Alarm Code Output			ALM Output
ALO1	ALO2	ALO3	
ON	ON	OFF	OFF

Note: OFF: Output transistor is OFF (alarm state).

ON: Output transistor is ON.

Status and Remedy for Alarm



Cause of the Problem		Solution
A	The SGDh amplifier is used immediately after disconnection of an option unit without clearing the unit detector.	To use the SGDh amplifier after disconnecting the option unit, execute Fn014 (option unit detection result clear), in the auxiliary function mode, and then cycle the power.
B	Option unit connection is defective.	Check and correct the connection.
C	Option unit is defective.	Replace the option unit.
D	Servo amplifier	Replace the servo amplifier.

■ A.F1: Power Line Open Phase

Display and Outputs

Alarm Outputs			
Alarm Code Output			ALM Output
ALO1	ALO2	ALO3	
ON	ON	OFF	OFF

Note: OFF: Output transistor is OFF (alarm state).

ON: Output transistor is ON.

Status and Remedy for Alarm

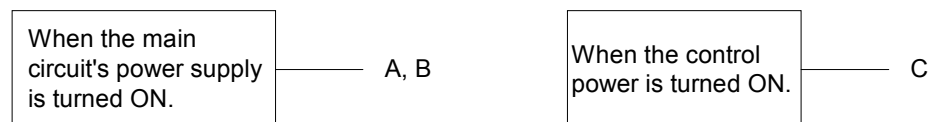

Cause of the Problem		Solution
A	One phase (L1, L2, or L3) of the main circuit power supply is disconnected.	<ul style="list-style-type: none"> Check power supply. Check wiring of the main circuit power supply. Check MCCB, noise filter, magnetic contactor.
B	There is one phase where the line voltage is low.	Check power supply.
C	Servo amplifier defective.	Replace servo amplifier.

Note: A and B tend to occur in a servo amplifier with a capacity of 500W or higher.

■ CPF00: Digital Operator Transmission Error 1

This alarm is not stored in the alarm history.

Display and Outputs

Alarm Outputs			
Alarm Code Output			ALM Output
ALO1	ALO2	ALO3	
Not Applicable			

Status and Remedy for Alarm

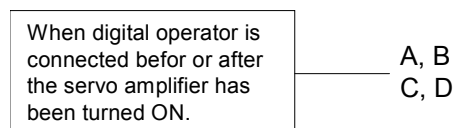

Cause of the Problem		Solution
A	Cable defective or poor contact between digital operator and servo amplifier.	<ul style="list-style-type: none"> Check connector connections. Replace cable.
B	Malfunction due to external noise.	Separate digital operator and cable from noise source.
C	Digital operator defective.	Replace digital operator.
D	Servo amplifier defective.	Replace servo amplifier.

■ CPF01: Digital Operator Transmission Error 2

This alarm is not stored in the alarm history.

Display and Outputs

Alarm Outputs			
Alarm Code Output			ALM Output
ALO1	ALO2	ALO3	
Not Applicable			

Status and Remedy for Alarm

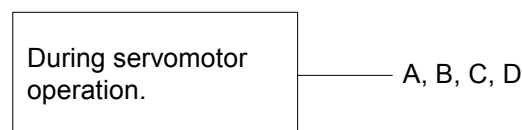

Cause of the Problem		Solution
A	Cable defective or poor contact between digital operator and servo amplifier.	<ul style="list-style-type: none"> • Check connector connections. • Replace cable.
B	Malfunction due to external noise.	Separate digital operator and cable from noise source.
C	Digital operator defective.	Replace digital operator.
D	Servo amplifier defective.	Replace servo amplifier.

■ A.- -: Normal Operation

This is not an alarm display.

Display and Outputs

Alarm Outputs			
Alarm Code Output			ALM Output
ALO1	ALO2	ALO3	
OFF	OFF	OFF	ON

Note: OFF: Output transistor is OFF (alarm state).
ON: Output transistor is ON.

9.2.2. Troubleshooting Problems with No Alarm Display

Use the tables below to identify the cause of a problem that causes no alarm display and follow the described corrective procedure.

Turn OFF the servo system power supply before starting the shaded procedures.

Contact YET if the problem cannot be solved by carefully following the described procedure.

Symptom	Cause	Comment	Solution
Servomotor does not start	Power not connected	Check voltage between power supply terminals.	Correct the power circuit.
	Loose connection	Check terminals of connectors (CN1, CN2).	Tighten any loose parts.
	Connector (CN1) external wiring incorrect	Check connector (CN1) external wiring	Refer to connection diagram and correct wiring.
	Servomotor or encoder wiring disconnected.	—	Reconnect wiring
	Overloaded	Run under no load.	Reduce load or replace with larger capacity servomotor.
	No speed/position references input	Check reference input pins.	Correctly input speed/position references.
	/S-ON is turned OFF	Check settings of parameters Pn50A.0 and Pn50A.1.	Turn /S-ON input ON.
	/P-CON input function setting incorrect	Check parameter Pn000.1.	Refer to section 5.3.5 and set parameters to match application.
	Reference pulse mode selection incorrect.	Refer to section 5.2.2	Correct setting of parameter Pn200.0.
	Encoder type differs from parameter setting.	Confirm whether incremental or absolute encoder is used.	Set parameter Pn002.2 to the encoder type being used.
	P-OT and N-OT inputs are turned OFF.	Refer to section 5.1.2.	Turn P-OT and N-OT input signals ON.
	CLR input is turned ON	Check status of error counter clear input.	Turn CLR input OFF.
SEN input is turned OFF.	When absolute encoder is used.	Turn SEN input ON.	
Servomotor moves suddenly, then stops	Servomotor or encoder wiring incorrect.	—	Refer to chapter 3 and correct wiring.
Suddenly stops during operation and will not restart	Alarm reset signal (/ALM-RST) is turned ON because an alarm occurred	—	Remove cause of alarm. Turn alarm reset signal (ALM-RST) from ON to OFF.
Unstable servo-motor speed.	Defective wiring connection to the motor.	Check the connections of the power lead (U-, V-, and W-phases) and the encoder connectors.	Tighten any loose terminals or connectors
Servomotor vibrates at approximately 200 to 400Hz.	Speed loop gain value too high.	—	Reduce speed loop gain (Pn100) preset value.
	Speed/position reference input wire too long.	—	Minimize length of speed/position reference input wire, with impedance not exceeding several hundred ohms
	Speed/position reference input wire is bundled with power cables.	—	Separate reference input wire at least 30cm from power cables.

Symptom	Cause	Comment	Solution
High rotation speed overshoot on starting and stopping.	Speed loop gain value too high.	—	Reduce speed loop gain (Pn100) preset value. Increase integration time constant (Pn101).
	Speed loop gain is too low compared to position loop gain.	—	Increase the value of parameter Pn100 (speed loop gain). Reduce the integration time constant (Pn101).
Servomotor overheated	Ambient temperature too high	Measure servomotor ambient temperature.	Reduce ambient temperature to 40°C maximum.
	Servomotor surface dirty	Visual check	Clean dust and oil from motor surface.
	Overloaded	Run under no load.	Reduce load or replace with larger capacity servomotor.
Abnormal noise	Incorrect mechanical mounting	Servomotor mounting screws loose?	Tighten mounting screws.
		Coupling not centered?	Center coupling.
		Coupling unbalanced?	Balance coupling.
	Bearing defective	Check noise and vibration near bearing.	Consult your YET representative if defective.
Machine causing vibrations	Foreign object intrusion, damage, or deformation of sliding parts of machine.	Consult with machine manufacturer.	
Speed reference 0V but servomotor rotates.	Speed reference voltage offset applied	—	Adjust reference offset. Refer to sections 7.2.4 and 7.2.5

9.2.3. Alarm Display Table

A summary of alarm displays and alarm code outputs is given in the following table.

Alarm Display	Alarm Code Output			ALM Output	Alarm Name	Description
	ALO1	ALO2	ALO3			
A.02	OFF	OFF	OFF	OFF	Parameter Breakdown*	EEPROM data of servo amplifier is abnormal.
A.03					Main Circuit Encoder Error	Detection data for power circuit is abnormal.
A.04					Parameter Setting Error*	The parameter setting is outside the allowable setting range.
A.05					Servomotor and Amplifier Combination Error	Servo amplifier and servomotor capacities do not match each other.
A.10	ON	OFF	OFF	OFF	Overcurrent or Heat Sink Overheated**	An overcurrent flowed through the IGBT. Heat sink of servo amplifier was overheated.
A.30	ON	ON	OFF	OFF	Regeneration Error Detected	•Regenerative circuit is faulty •Regenerative resistor is faulty.
A.32					Regenerative Overload	Regenerative energy exceeds regenerative resistor capacity.
A.40	OFF	OFF	ON	OFF	Overvoltage	Main circuit DC voltage is excessively high.

* These alarms are not reset by the alarm reset signal (/ALM-RST). Eliminate the cause of the alarm and then turn OFF the power supply to reset the alarms.

Note: OFF: Output transistor is OFF.

ON: Output transistor is ON.

** This alarm display appears only within the range of 30W to 1kW.

Alarm Display	Alarm Code Output			ALM Output	Alarm Name	Description
	ALO1	ALO2	ALO3			
A.41					Undervoltage	Main circuit DC voltage is excessively low.
A.51	ON	OFF	ON	OFF	Overspeed	Rotational speed of the motor is excessively high.
A.71	ON	ON	ON	OFF	Overload: High Load	The motor was operating for several seconds to several tens of seconds under a torque largely exceeding ratings.
A.72					Overload: Low Load	The motor was operating continuously under a torque largely exceeding ratings
A.73					Dynamic Brake Overload	When the dynamic brake was applied, rotational energy exceeded the capacity of dynamic brake resistor.
A.74					Overload of Surge Current Limit Resistor	The main circuit power was frequently turned ON and OFF.
A.7A					Heat Sink Overheated**	The heat sink of servo amplifier overheated.
A.81	OFF	OFF	OFF	OFF	Absolute Encoder Backup Error*	All the power supplies for the absolute encoder have failed and position data was cleared.
A.82					Encoder Checksum Error*	The checksum results of encoder memory is abnormal.
A.83					Absolute Encoder Battery Error	Battery voltage for the absolute encoder has dropped.
A.84					Absolute Encoder Data Error*	Received absolute data is abnormal.
A.85					Absolute Encoder Overspeed	The encoder was rotating at high speed when the power was turned ON.
A.86					Encoder Overheated	The internal temperature of encoder is too high.
A.b1					Reference Speed Input Read Error	The A/D converter for reference speed input is faulty.
A.b2					Reference Torque Input Read Error	The A/D converter for reference torque input is faulty.
A.bF					System Alarm*	A system error occurred in the servo amplifier.
A.C1	ON	OFF	ON	OFF	Servo Overrun Detected	The servomotor ran out of control.
A.C2					Phase Finding Error	The commutation (phase finding) procedure for motor with A quad B encoder was faulty
A.C8					Absolute Encoder Clear Error and Multi-Turn Limit Setting Error*	The multi-turn for the absolute encoder was not properly cleared or set.
A.C9					Encoder Communications Error*	Communications between servo amplifier and encoder is not possible.
A.CA					Encoder Parameter Error*	Encoder parameters are faulty.

* These alarms are not reset by the alarm reset signal (/ALM-RST). Eliminate the cause of the alarm and then turn OFF the power supply to reset the alarms.

** This alarm display appears only within the range of 30W to 1kW.

Note: OFF: Output transistor is OFF. ON: Output transistor is ON.

Alarm Display	Alarm Code Output			ALM Output	Alarm Name	Description
	ALO1	ALO2	ALO3			
A.Cb					Encoder Echo back Error*	Contents of communications with encoder is incorrect.
A.CC	ON	OFF	ON	OFF	Multi-Turn Limit Disagreement	Different multi-turn limits have been set in the encoder and servo amplifier.
A.d0	ON	ON	OFF	OFF	Position Error Pulse Overflow	Position error pulse exceeded parameter (Pn505).
A.E7	OFF	ON	ON	OFF	Option Unit Detection Error	Option unit detection fails.
A.F1	OFF	ON	OFF	OFF	Power Line Open Phase	One phase is not connected in the main power supply
CPF00	Not Specified				Digital Operator Transmission Error	Digital operator (JUSP-OP02A-2) fails to communicate with servo amplifier (e.g., CPU error).
CPF01						
A.--	OFF	OFF	OFF	ON	Not an error	Normal operation status

* These alarms are not reset by the alarm reset signal (/ALM-RST). Eliminate the cause of the alarm and then turn OFF the power supply to reset the alarms.

** This alarm display appears only within the range of 30W to 1kW.

Note: OFF: Output transistor is OFF.

ON: Output transistor is ON.

9.2.4. Warning Displays

The correlation between warning displays and warning code outputs is shown in the following table.

Warning Display	Warning Code Outputs			Warning Name	Meaning of Warning
	ALO1	ALO2	ALO3		
A.91	ON	OFF	OFF	Overload	This warning occurs before either of the overload alarms (A.71 or A.72) occurs. If the warning is ignored and operation continues, an overload alarm may result.
A.92	OFF	ON	OFF	Regenerative Overload	This warning occurs before the regenerative overload alarm (A.32) occurs. If the warning is ignored and operation continues, a regenerative overload alarm may result.

Appendix A. Host Controller Connection Examples

This appendix provides examples for XtraDrive servo amplifiers connected to typical host controllers. Refer to the manuals for the host controller when actually connecting to them.

A.1.	Connecting the GL-series MC20 Motion Module	A-2
A.2.	Connecting the CP-9200SH Servo Controller Module (SVA)	A-3
A.3.	Connecting the GL-series B2813 Positioning Module	A-4
A.4.	Connecting OMRON's C500-NC221 Position Control Unit	A-5
A.5.	Connecting OMRON's C500-NC112 Position Control Unit	A-6
A.6.	Connecting MITSUBISHI's AD72 Positioning Unit	A-7
A.7.	Connecting MITSUBISHI's AD75 Positioning Unit	A-8

A.1. Connecting the GL-series MC20 Motion Module

The following diagram shows an example of connecting to the GL-series MC20 Motion Module. In this example, the servo amplifier is used in Speed Control Mode.

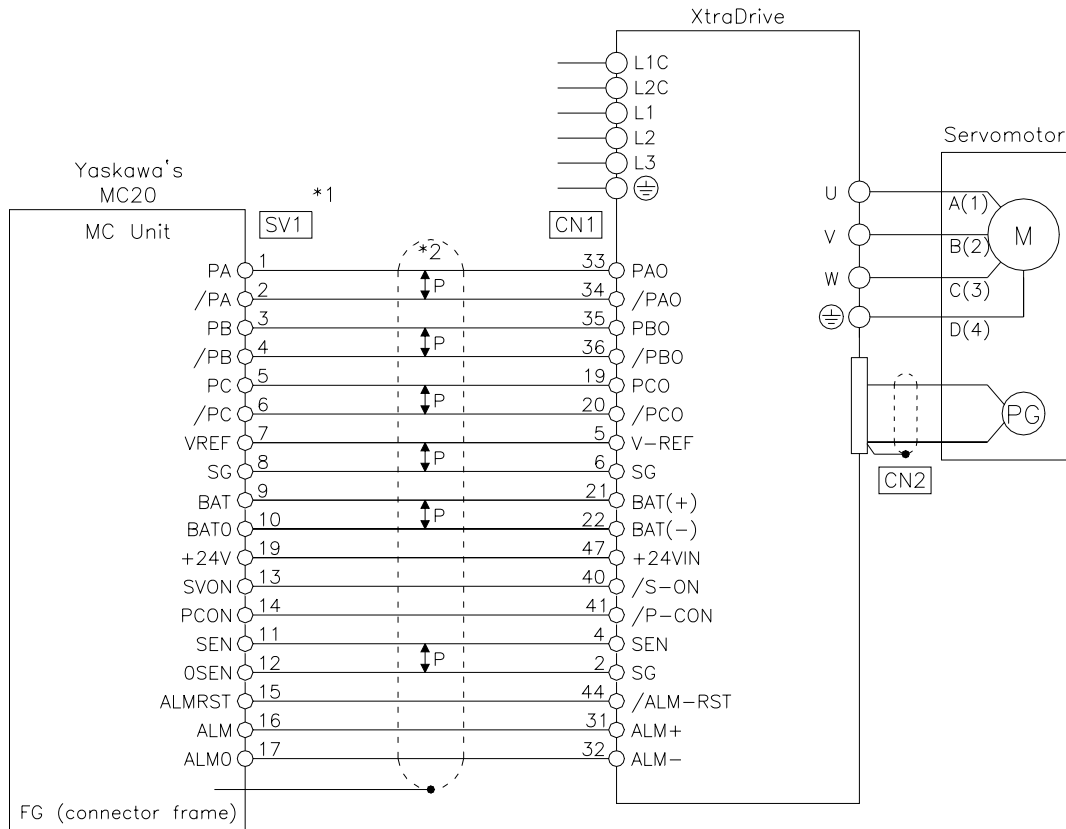

*1. These pin numbers are the same for SV2 to SV4.

*2. ↑↓P indicates twisted-pair wires.

A.2. Connecting the CP-9200SH Servo Controller Module (SVA)

The following diagram shows an example of connecting to the CP-9200SH servo controller Module (SVA). In this example, the servo amplifier is used in Speed Control Mode.

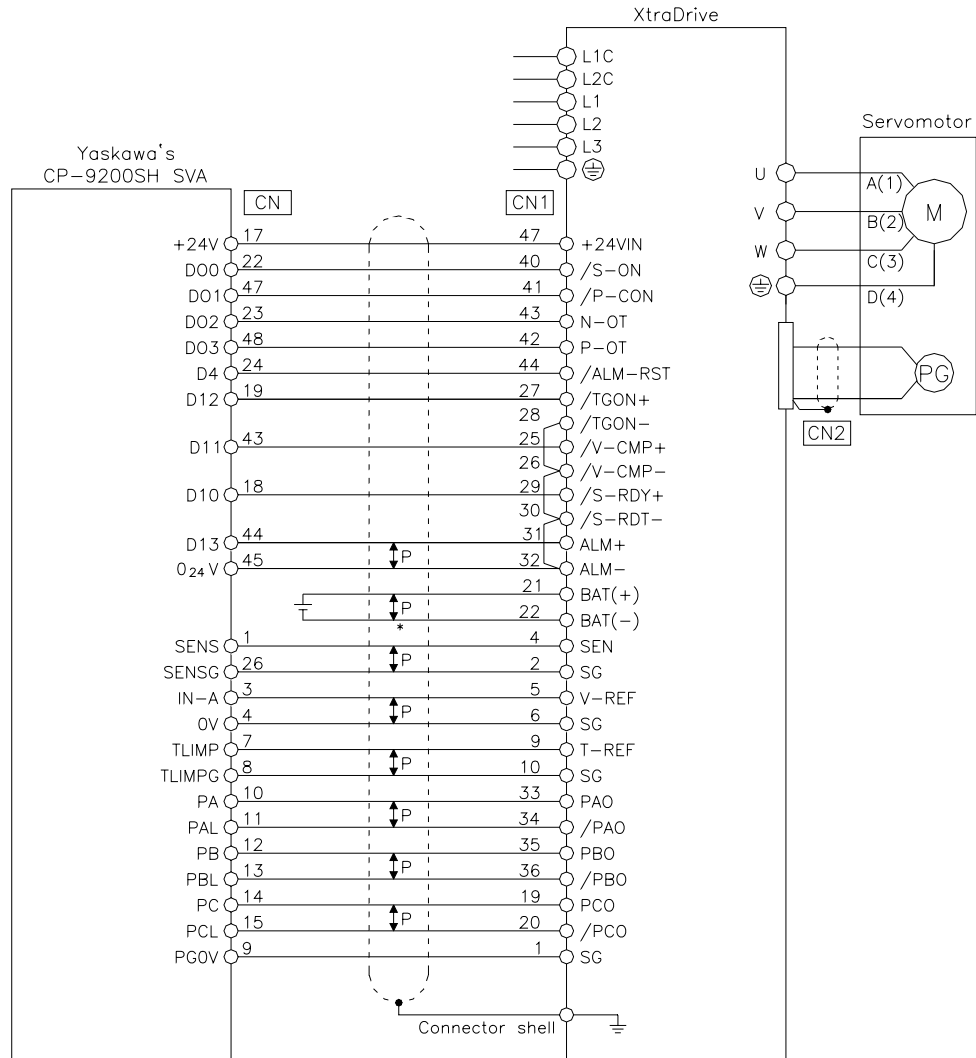

*↕P indicates twisted-pair wires.

A.3. Connecting the GL-series B2813 Positioning Module

The following diagram shows an example of connecting to the GL-series B2813 Positioning Module. In this example, the servo amplifier is used in Position Control Mode.

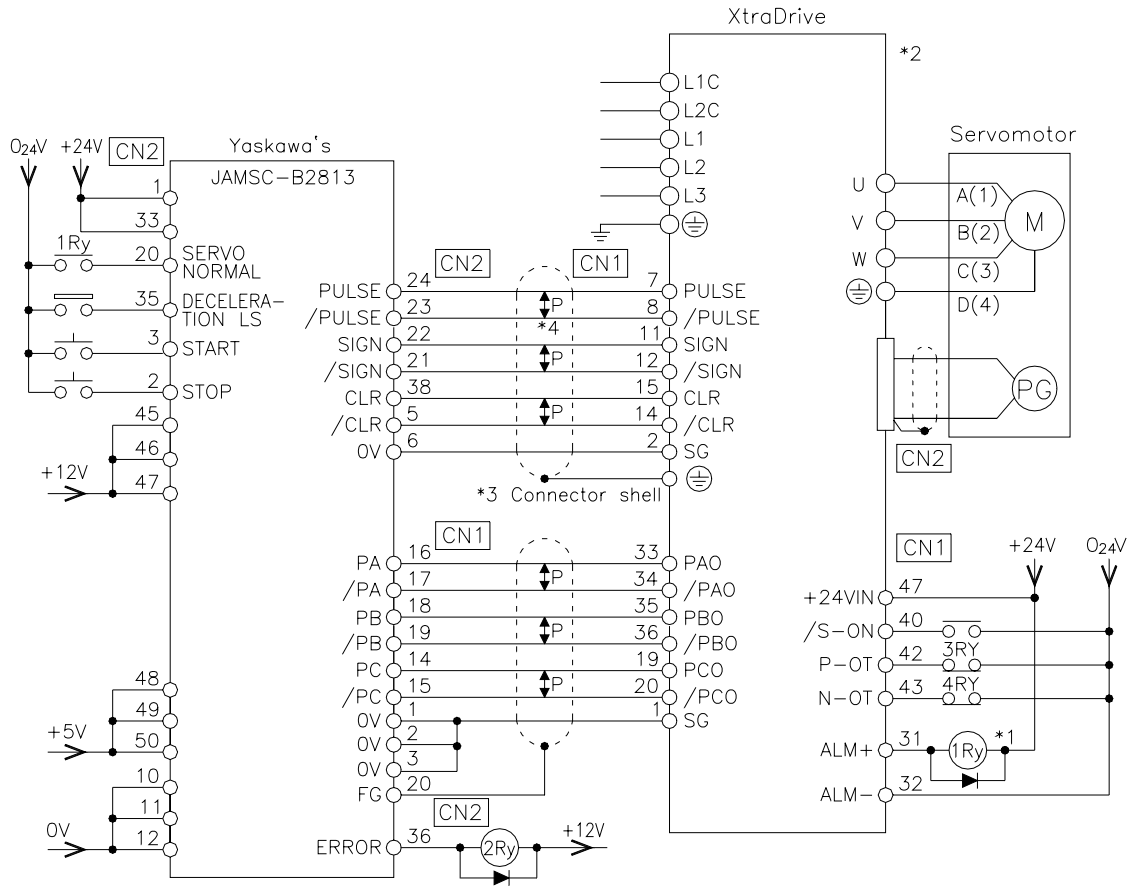

- *1. The ALM signal is output for approximately two seconds when the power is turned ON. Take this into consideration when designing the power ON sequence. The ALM signal actuates the alarm detection relay 1Ry to stop main circuit power supply to the XtraDrive.
- *2. Set parameter Pn200.0 to "1".
- *3. Connect the shield wire to the connector shell.
- *4. P indicates twisted pair wires.

A.4. Connecting OMRON's C500-NC222 Position Control Unit

The following diagram shows an example of connecting to an OMRON C500-NC222 Position Control Unit. In this example, the servo amplifier is used in Speed Control Mode.

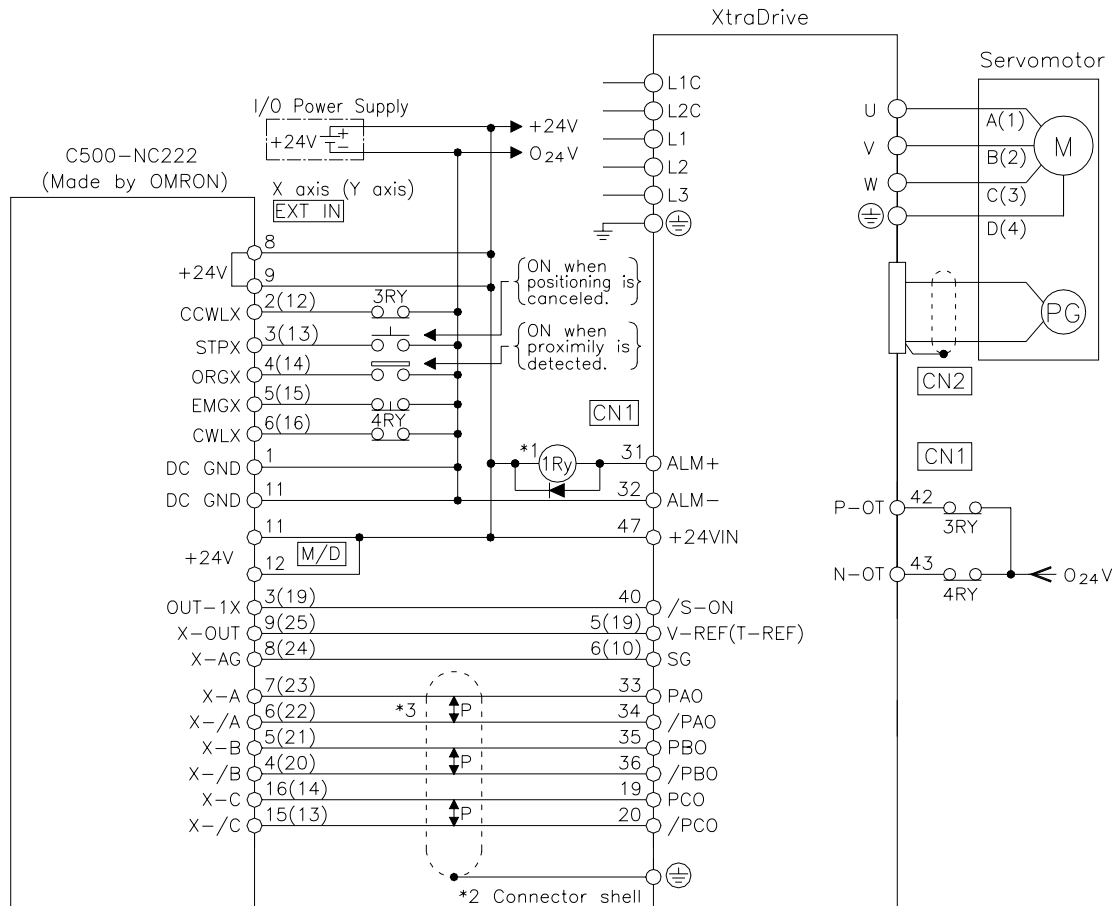

- *1. The ALM signal is output for approximately two seconds when the power is turned ON. Take this into consideration when designing the power ON sequence. The ALM signal actuates the alarm detection relay 1Ry to stop main circuit power supply to the XtraDrive.
- *2. Connect the shield wire of the I/O cable to the connector shell.
- *3. P indicates twisted pair wires.

Note: Only signals applicable to OMRON's C500NC222 Position Control Unit and YET's XtraDrive are shown here.

A.5. Connecting OMRON's C500-NC112 Position Control Unit

The following diagram shows an example of connecting to the OMRON C500-NC112 Position Control Unit. In this example, the servo amplifier is used in the position control mode.

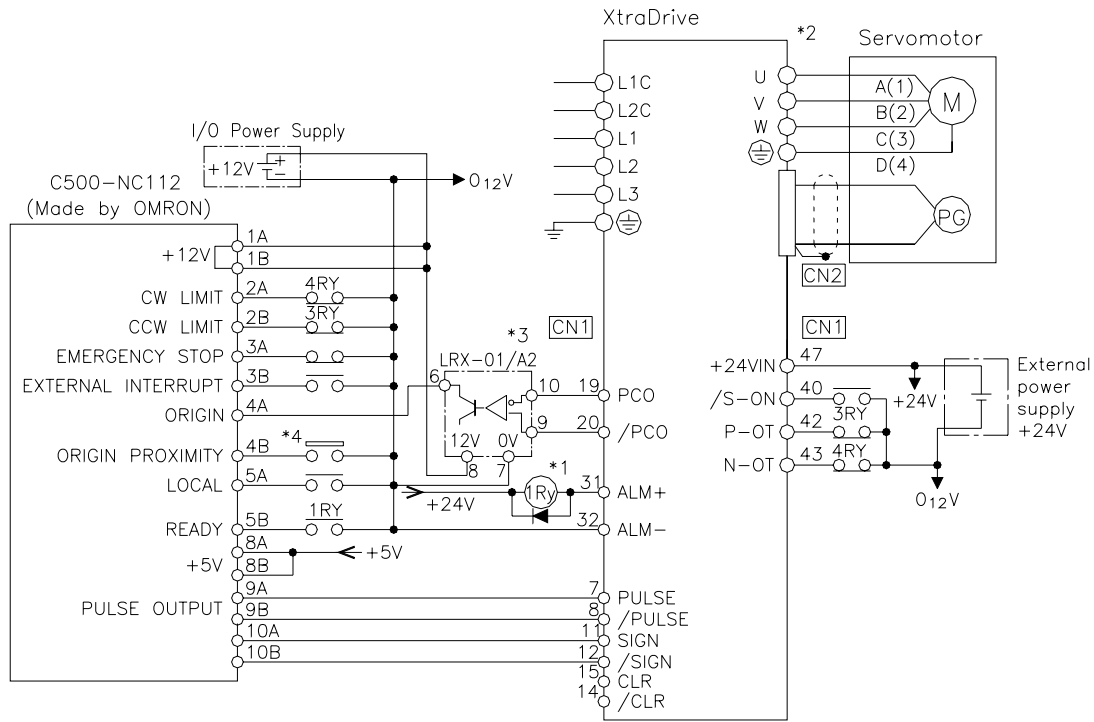

- *1. The ALM signal is output for approximately two seconds when the power is turned ON. Take this into consideration when designing the power ON sequence. The ALM signal actuates the alarm detection relay 1Ry to stop main circuit power supply to XtraDrive.
- *2. Set parameter Pn200.0 to "1".
- *3. Manufactured by Yaskawa Controls Co.

Note: Only signals applicable to OMRON's C500NC112 Position Control Unit and YET's XtraDrive are shown here.

A.6. Connecting MITSUBISHI's AD72 Positioning Unit

The following diagram shows an example of connecting to the MITSUBISHI AD72 Positioning Unit. In this example, the servo amplifier is used in Speed Control Mode.

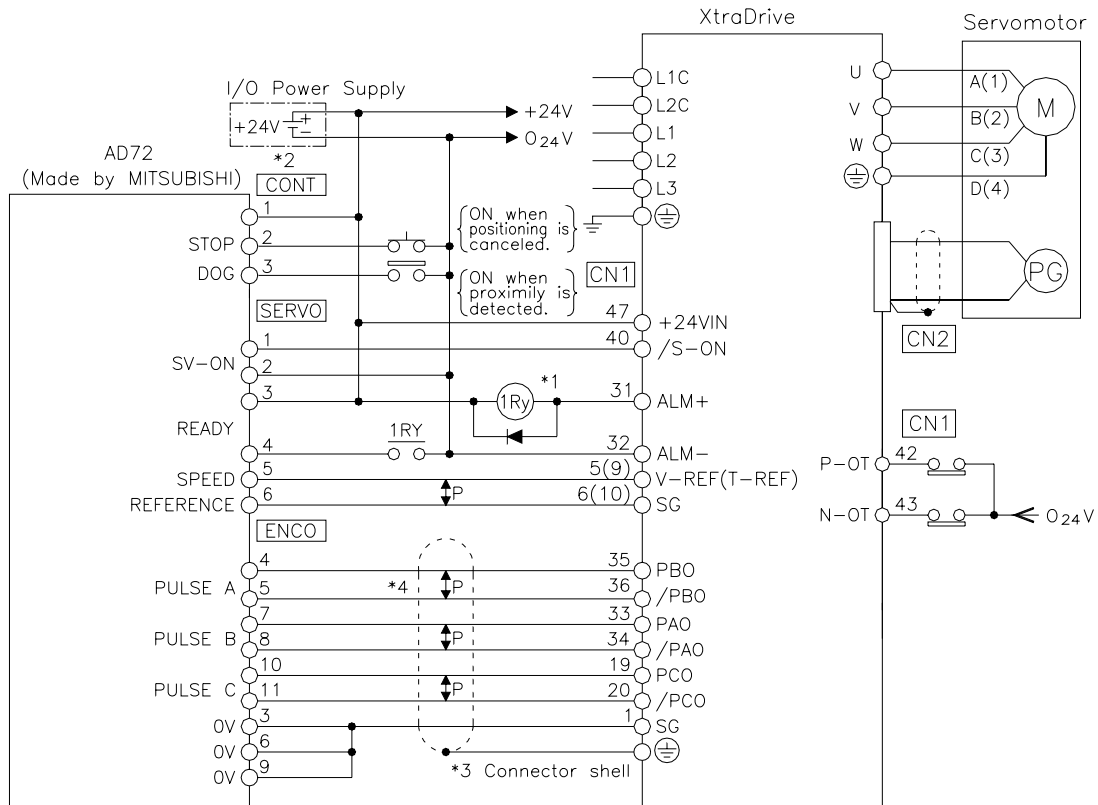

- *1. The ALM signal is output for approximately two seconds when the power is turned ON. Take this into consideration when designing the power ON sequence. The ALM signal actuates the alarm detection relay 1Ry to stop main circuit power supply to XtraDrive.
- *2. Pin numbers are the same both for X-axis and Y-axis.
- *3. Connect the connector wire of the cable to the connector shell.
- *4. P indicates twisted pair wires.

Note: Only signals applicable to Mitsubishi's AD72 Positioning Unit and YET's XtraDrive are shown here.

A.7. Connecting MITSUBISHI's AD75 Positioning Unit

The following diagram shows an example of connecting to the MITSUBISHI AD75 Positioning Unit. In this example, the servo amplifier is used in Position Control Mode.

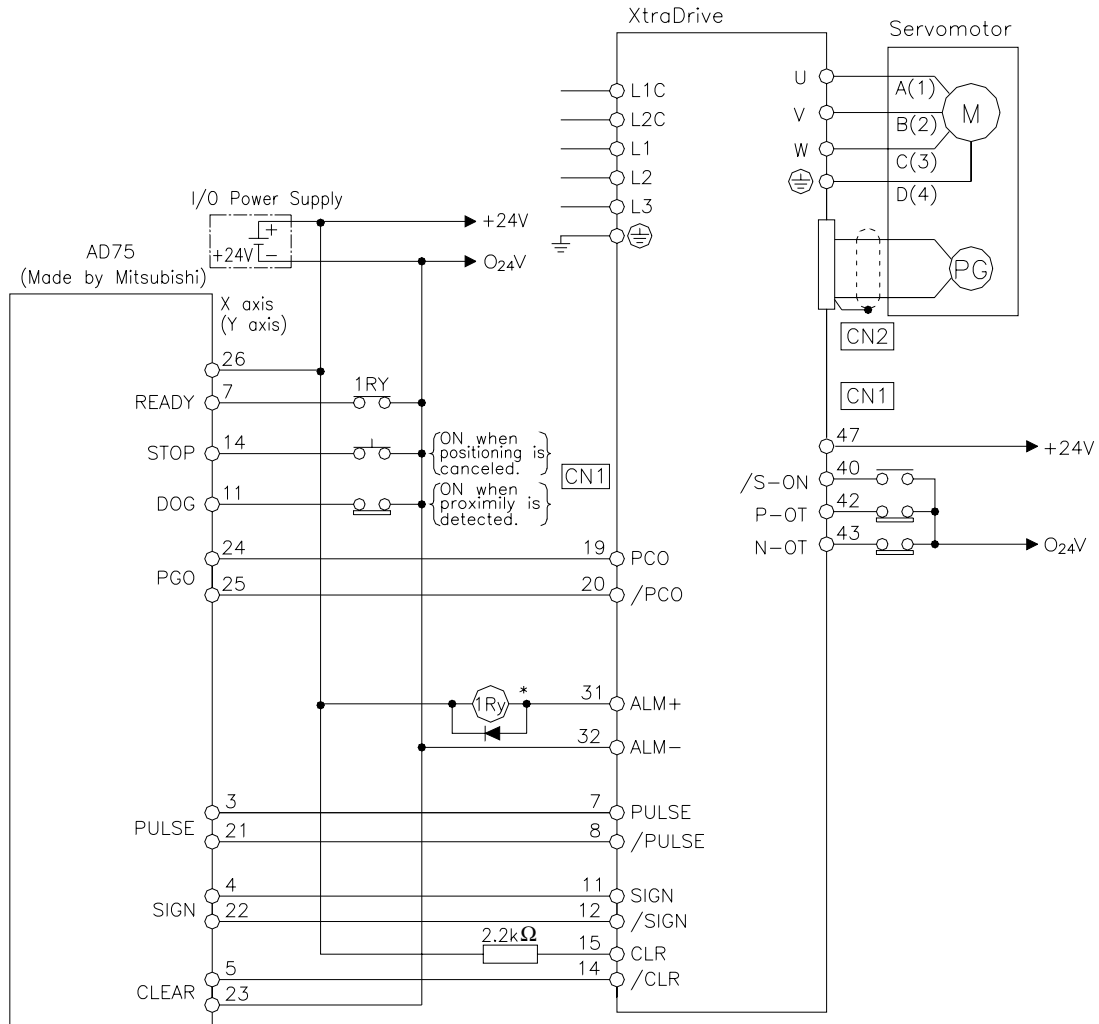

* The ALM signal is output for approximately two seconds when the power is turned ON. Take this into consideration when designing the power ON sequence. The ALM signal actuates the alarm detection relay 1RY to stop main circuit power supply to XtraDrive.

Note: Only signals applicable to MITSUBISHI's AD75 Positioning Unit and YET's XtraDrive are shown here.

Appendix B. Special Wiring

This appendix provides examples for XtraDrive servo amplifiers connected to typical host controllers. Refer to the manuals for the host controller when actually connecting to them.

B.1.	Wiring Precautions.....	B-2
B.2.	Wiring for Noise Control.....	B-5
B.3.	Using More Than One XtraDrive	B-9
B.4.	Extending Encoder Cables.....	B-10
B.5.	400V Power Supply Voltage	B-12
B.6.	Reactor for Harmonic Suppression.....	B-14

B.1. Wiring Precautions

To ensure safe and stable operation, always observe the following wiring precautions:

1. Always use the following cables for reference input and encoder wiring.

-	Cable Type	Yaskawa Drawing Number	Maximum Allowable Length	
Reference Input	Twisted pair wires	JZSP-CKI01	118in (3m)	
Encoder	Multi-conductor shielded twisted air wire	JZSP-CMP00	SGMAH, SGMPH	787in (20m)
		JZSP-CMP02	SGMGH, SGMSH	1969in (50m)

- Trim off the excess portion of the cable to minimize the cable length.
2. For a ground wire use as large a wire as possible: AWG14 (2.0mm²) or larger.
 - At least class-3 ground (100Ω. maximum) is recommended.
 - Ground to one point only.
 - If the motor is insulated from the machine, ground the motor directly.
 3. Do not bend or apply tension to cables.
The conductor of a signal cable is very thin (0.0079 to 0.012in. (0.2 to 0.3mm)), handle the cables with care.
 4. Use a noise filter to prevent noise interference.
(For details, refer to 5.8.2 *Wiring for Noise Control*).
 - If the equipment is to be used near private houses or may receive noise interference, install a noise filter on the input side of the power supply line.
 - Since this servo amplifier is designed as an industrial device, it provides no mechanism to prevent noise interference.

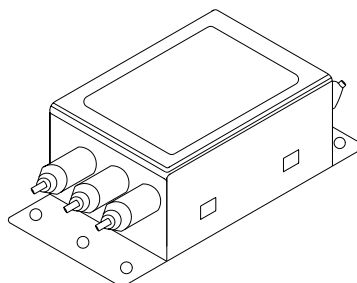

5. To prevent malfunction due to noise, take the following actions:
 - Position the input reference device and noise filter as close to the servo amplifier as possible.
 - Always install a surge absorber circuit in the relay, solenoid, and electromagnetic contactor coils.
 - The distance between a power line (such as a power supply line or motor cable) and a signal line must be at least 11.8in (30cm). Do not put the power and signal lines in the same duct or bundle them together.
 - Do not share the power supply with an electric welder or electrical discharge machine. When the servo amplifier is placed near a high-frequency oscillator, install a noise filter on the input side of the power supply line.

Note: 1. Since the servo amplifier uses high-speed switching elements, signal lines may receive noise. To prevent this, always take the above precautions.
2. For details on grounding and noise filters, refer to 5.8.2 Wiring for Noise Control.

6. Use a UL listed molded-case circuit breaker (MCCB) or fuse in accordance with the National Electrical Code (NEC) to protect the power supply line from high voltage.
 - This servo amplifier connects directly to a commercial power supply without a transformer, so always use an MCCB or fuse to protect the servo system from accidental high voltage.
 - Select an appropriate MCCB or fuse according to the servo amplifier capacity and the number of servo amplifiers to be used as shown in the following table.

■ MCCB or Fuse According to Power Capacity

The following table shows the MCCB or fuse capacity for each power supply capacity.

Main Circuit Power Supply	Servo Amplifier Model		Applicable Motor	Power Capacity per Servo Amplifier (kVA)*	Current Capacity per MCCB or Fuse(A _{rms})* **
	Capacity (kW)	XD-			
Single-phase 200V	0.05	P5	SGMAH-A5A	0.25	4
	0.10	01	SGMAH-01A	0.40	
			SGMPH-01A		
	0.20	02	SGMAH-02A	0.75	
			SGMPH-02A		
	0.40	04	SGMAH-04A	1.2	8
			SGMPH-04A		
0.75	08	SGMAH-08A	2.1	11	
		SGMPH-08A			
1.50	15	SGMPH-15A	4.0	19	
Three-phase 400V	1.0	10	SGMGH-09D	2.3	3.4
			SGMSH-10D		
			SGMUH-10D		
	2.0	20	SGMGH-09D	4.9	7.1
			SGMSH-10D		

* This is the net value at the rated load. When actually selecting fuses, determine the capacity using the prescribed derating.

** Operating characteristics (at 25°C): 2 seconds or more for 200%, 0.01 second or more for 700%

- Note:**
1. A fast-operating fuse cannot be used because the servo amplifier power supply is a capacitor input type. A fast-operating fuse may blow when the power is turned ON.
 2. XtraDrive servo amplifiers do not have built-in ground protection circuits. To configure a safer system, install a ground fault interrupter with or without a circuit breaker for protection against overload and short circuit conditions.

B.2. Wiring for Noise Control

■ Wiring Example

This servo amplifier uses high-speed switching elements in the main circuit. It may receive “switching noise” from these high-speed switching elements if wiring or grounding around the servo amplifier is not appropriate. To prevent this, always wire and ground the servo amplifier correctly.

This servo amplifier has a built-in microprocessor (CPU). To protect it from external noise install a noise filter in the appropriate place.

The following is an example of wiring for noise control.

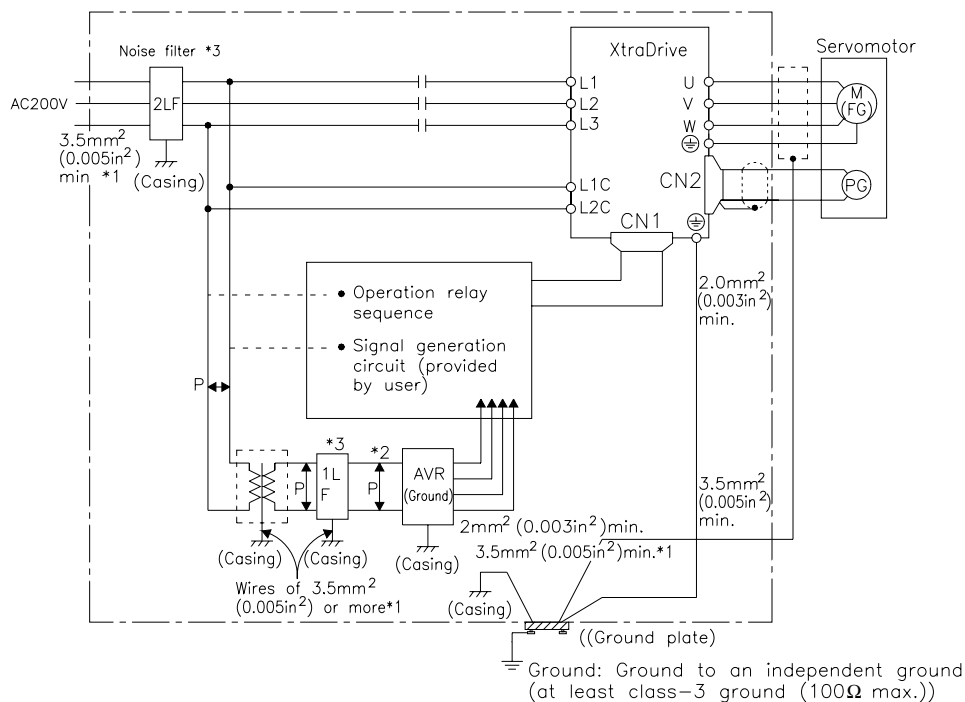

Note: * When using a noise filter, follow the precautions in *Using Noise Filters* on the following page.

** For ground wires connecting to the casing, use a wire with a thickness of at least 0.005in^2 (3.5mm^2), preferably a braided flat copper wire.

■ Correct Grounding

Grounding the Motor Frame

Always connect servomotor's frame terminal FG to the XtraDrive's ground terminal \oplus . Also be sure to ground the ground terminal \oplus .

If the servomotor is grounded via the machine, switching noise current will flow from the servo amplifier power unit through motor stray capacitance. The grounding of the motor frame is required to prevent the adverse effects of switching noise.

Noise on the Reference Input Line

If the reference input line is affected by noise, ground the 0V line (SG) of the reference input line. If the main circuit wiring for the motor is accommodated in a metal conduit, ground the conduit and its junction box.

All grounds must be made to only one point in the system.

■ Using Noise Filters

Use a noise suppression filter to prevent noise generated by the power supply line. Install a noise filter on the power supply line for peripheral equipment as necessary.

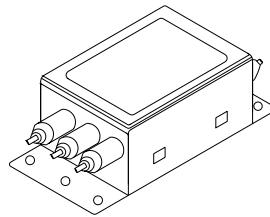

The following table recommends noise filters for each servo amplifier model.

Voltage	Servo Amplifier Model	Recommended Noise Filter	
		Model	Manufacturer
Single-phase, 200V	XD - P3 to XD - 02	FN2070-6/07	Schaffner
	XD - 04	FN2070-10/07	
	XD - 08	FN2070-16/07	
	XD - 15	FN350-30/33	
Three-phase, 400V	XD - 10	FN258L-7/07	
	XD - 20, 30	FN258L-16/07	

Note: Filters manufactured by Schaffner.

■ Installation and Wiring a Noise Filter

Incorrect application of a noise filter significantly reduces its benefits. Follow these instructions for the best results.

- Separate the input lines from the output lines.

Do not put the input and output lines in the same duct or bundle them together.

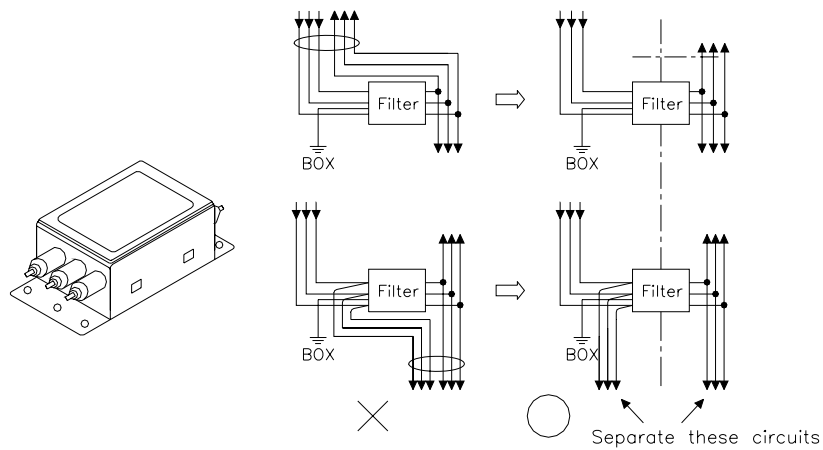

- Isolate the noise filter ground wire from the output lines.

Do not put the noise filter ground wire, output lines and other signal lines in the same duct or bundle them together.

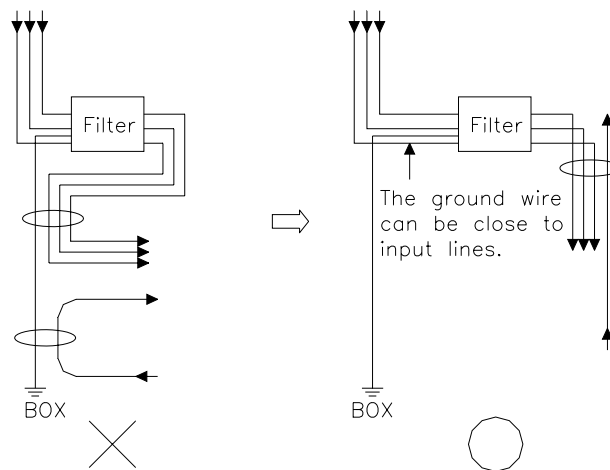

- Connect the noise filter ground wire directly to the ground plate.
Do not connect the noise filter ground wire to other ground wires.

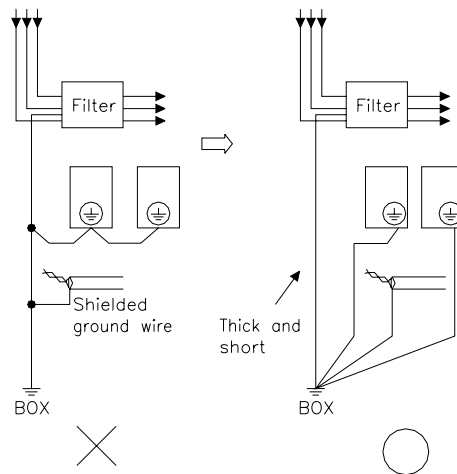

- When grounding a noise filter inside an enclosure:
If a noise filter is located inside an enclosure, connect the noise filter ground wire and the ground wires from other devices inside to the ground plate for the enclosure first, then ground these wires.

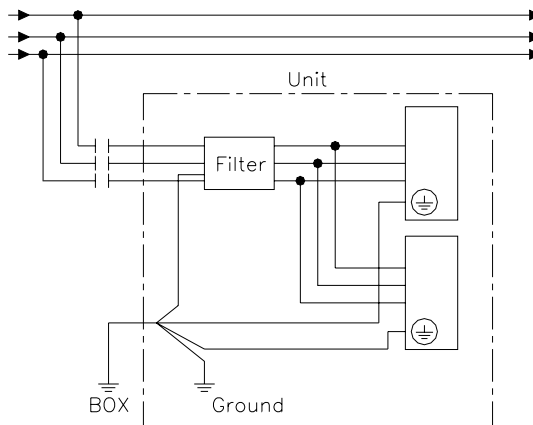

B.3. Using More Than One XtraDrive

The following diagram is an example of the wiring when more than one XtraDrive is used.

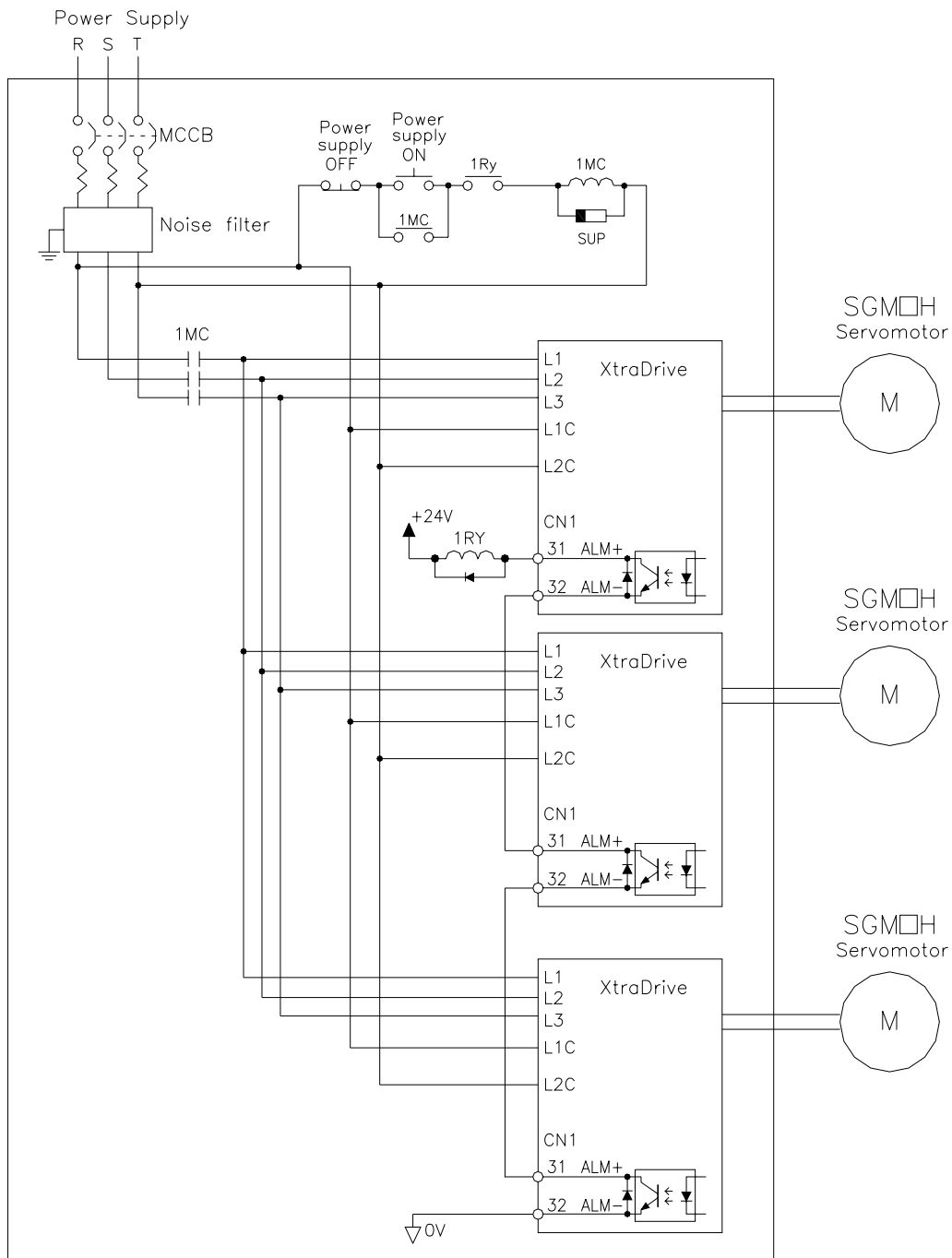

Note: Wire the system to comply to National Electrical Code.

Connect the alarm output (ALM) terminals for the three servo amplifiers in series to enable alarm detection relay 1Ry to operate. The output transistor is turned OFF when the ALM output signal enters an alarm state.

Multiple servos can share a single MCCB or noise filter. Always select an MCCB or noise filter that has enough capacity for the total power capacity (load conditions) of those servos. For details, refer to *5.8.1 Wiring Precautions*.

B.4. Extending Encoder Cables



Standard encoder cables have a maximum length of 20m. If a longer cable is required, prepare an extension cable as described below. The maximum allowable cable length is 50m.

■ Preparing 50m (164.0ft) Encoder Cables

- Cable Model Number: UL2076-SB
Cables are ordered in units of meters. Specify the length, when ordering.
- Connectors or Connector Kits

Connector Type		Model
XtraDrive end	Encoder connector (CN2) socket	JZSP-CMP9-1
Motor end	Encoder connector socket for SGMAH and SGMPH servomotors	JZSP-CMP9-2
	Encoder connector plug and cable plug for SGMGH and SGMSH servomotors	Plug L: MS3108B20-29S Straight: MS3106B20-29S Cable clamp: MS3057-12A

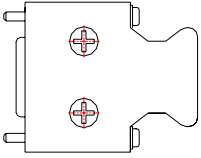
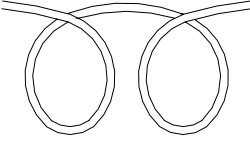
• Preparing Encoder Cables

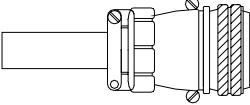
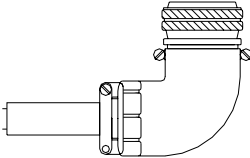
• Encoder Connector at XtraDrive end	• Cable Line	• Encoder Connector at Motor End	
			For SGMAH and SGMPH servomotors
			For SGMGH, SGM SH, and SGMUH servomotors
			

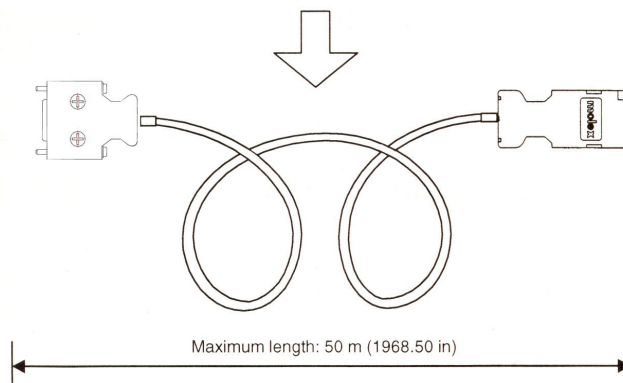

B.5. 400V Power Supply Voltage

Caution

- Do not connect the servo amplifier directly to any voltage level other than what is specified on the servomotor.
Doing so will destroy the servo amplifier.

There are 3 types of XtraDrive servo amplifiers. The power supply voltages are: single-phase 200 V_{ac}, three-phase 200V and three-phase 400 V_{ac}.

For 200V servo amplifiers that use three-phase 400 V_{ac} power supply, prepare the following voltage conversion transformer (single-phase or three-phase).

Primary Voltage	Secondary Voltage
400 V _{ac} or 440V	200 V _{ac}

Refer to the capacities shown in the following table when selecting a voltage conversion transformer.

Voltage	Servo Amplifier Model	Voltage capacity per Servo Amplifier kVA
Single-phase 200V	XD-P5	0.25
	XD-01	0.40
	XD-02	0.75
	XD-04	1.2
	XD-08	2.1

* This is the net value at the rated load.

IMPORTANT

Turn the power supply ON and OFF at the primary winding of the voltage conversion transformer when using a 400V class power supply.

Transformer inductance will cause a voltage surge if the power is turned ON/OFF at the secondary winding, damaging the servo amplifier.

■ **Single-phase Power Supply Connection Example**

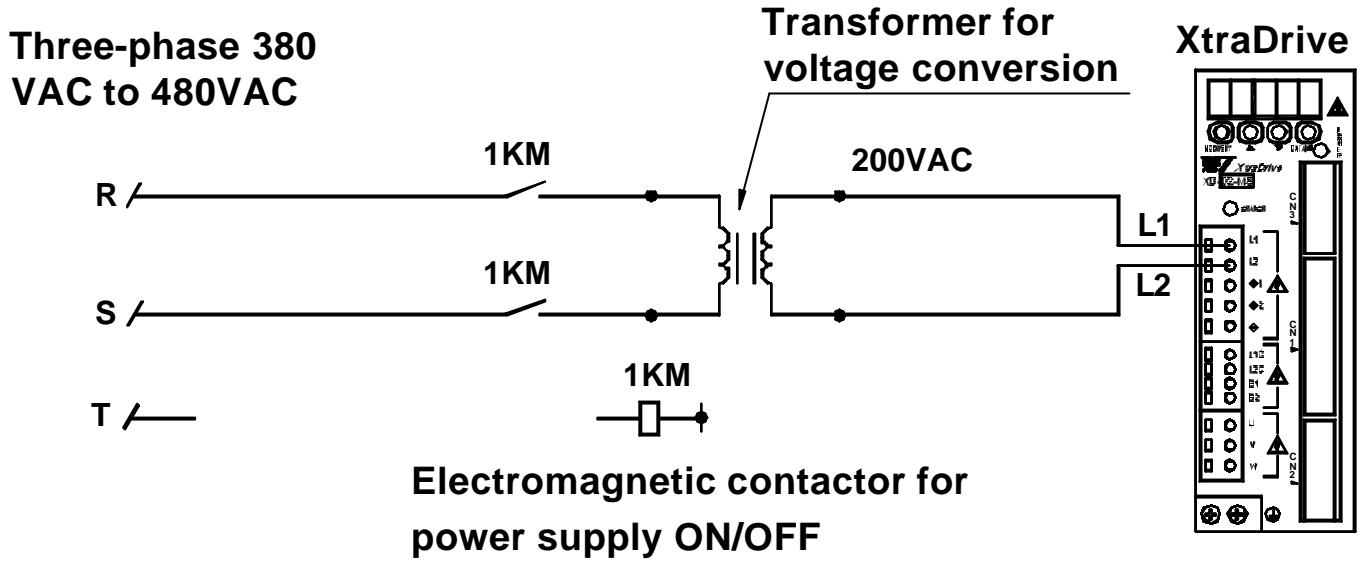

B.6. Reactor for Harmonic Suppression

XtraDrive servo amplifiers have DC reactor connection terminals for power supply harmonic suppression.

■ Connecting a DC Reactor

The DC reactor is connected in series to the rectifier circuit's output side. Refer to *3.2 Servo Amplifier Internal Block Diagrams*.

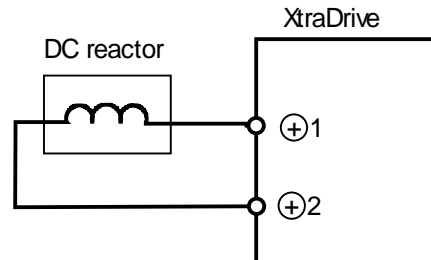

By default XtraDrive shipped with (+)1 and (+)2 terminal short-circuited. Remove the lead wire between the two terminals and connect the DC reactor instead.

■ DC Reactor Specifications

For DC reactor specifications provided by Yaskawa refer to Appendix C of this manual.

Appendix C. Specifications for Peripheral Devices

This chapter provides specifications and dimensional drawings for peripheral devices required in XtraDrive Series Servo System.

C.1.	Connector Terminal Block Converter Unit JUSP-TA50P	C-2
C.2.	External Regenerative Resistors	C-4
C.3.	DC Reactors for Power Supplies Designed for Minimum Harmonics	C-6
C.4.	Brake Power Supplies	C-8
C.5.	Surge Suppressor	C-9
C.6.	Magnetic Contactor	C-9
C.7.	Variable Resistor for Speed Setting	C-9
C.8.	CN1 I/O Signal Connector	C-9
C.9.	Connecting Pulse A/B Encoder without C Pulse (Index Pulse)	C-10
C.10.	Absolute Encoder Battery	C-11
C.11.	Cables for Connecting PC to XtraDrive	C-12
C.11.1.	RS-232 Communication Cable	C-12
C.11.2.	Cable with RS-232 to RS-422 Active Adapter	C-14
C.12.	Connecting Regenerative Resistors	C-15
C.13.	Connecting Yaskawa Option Board	C-19
C.13.1.	Attaching the Option Board	C-19
C.13.2.	Detaching the Option Board	C-19

C.1. Connector Terminal Block Converter Unit JUSP-TA50P

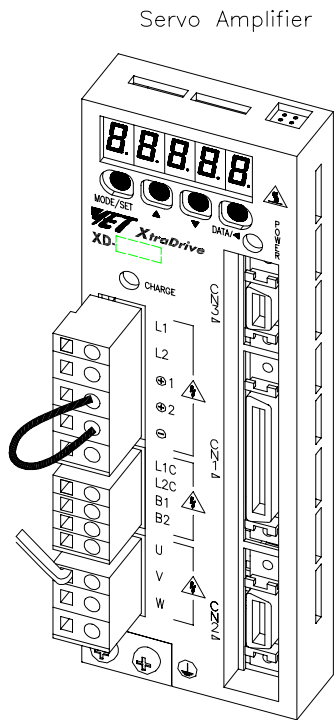

Servo Amplifier

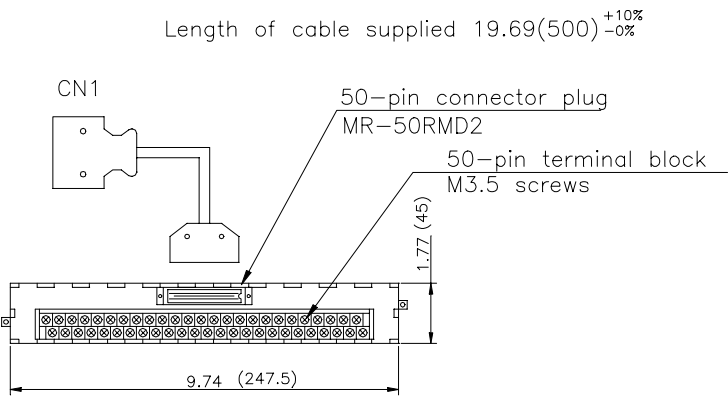

Connector terminal block converter unit
JUSP-TA50P (cable included)

Mounting hole diagram

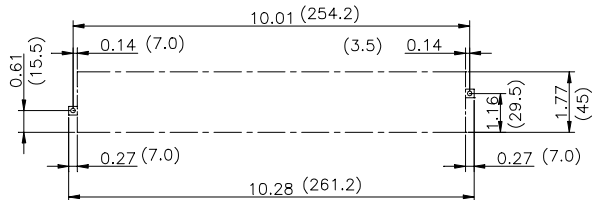

* Terminal specifications: see the following page

■ **JUSP-TA50P Terminal Block Pin Numbers and Signal Names.**

Xtradrive			JUSP-TA50P Terminal Block Unit		
Signal Name		CN1 pin no.		Connector No.	Terminal Block No.
SG		1		A1	1
SG		2		B1	2
PL1		3		A2	3
SEN		4		B2	4
V-REF		5		A3	5
SG		6		B3	6
PULS		7		A4	7
/PULS		8		B4	8
T-REF		9		A5	9
SG		10		B5	10
SIGN		11		A6	11
/SIGN		12		B6	12
PL2		13		A7	13
/CLR		14		B7	14
CLR		15		A8	15
		16		B8	16
		17		A9	17
PL3		18		B9	18
PCO		19		A10	19
/PCO		20		B10	20
BAT(+)		21		A11	21
BAT(-)		22		B11	22
		23		A12	23
		24		B12	24
/V-CMP+		25		A13	25
/V-CMP-		26		B13	26
/TGON+		27		A14	27
/TGON-		28		B14	28
/S-RDY+		29		A15	29
/S-RDY-		30		B15	30
ALM+		31		A16	31
ALM-		32		B16	32
PAO		33		A17	33
/PAO		34		B17	34
PBO		35		A18	35
/PBO		36		B18	36
ALO1		37		A19	37
ALO2		38		B19	38
ALO3		39		A20	39
/S-ON		40		B20	40
/P-CON		41		A21	41
P-OT		42		B21	42
N-OT		43		A22	43
/ALM-RST		44		B22	44
/P-CL		45		A23	45
/N-CL		46		B23	46
+24VIN		47		A24	47
PSO		48		B24	48
/PSO		49		A25	49
		50		B25	50
Connector Case					

Cable: Supplied with the terminal block

↕ P: Twisted-par

C.2. External Regenerative Resistors

Regenerative resistors can be externally mounted onto all XtraDrive models. Mount a regenerative resistor externally if regenerative energy exceeds the capacity of the XtraDrive.

If a regenerative resistor is to be mounted externally, the jumper between B2 and B3 terminals of XtraDrive must be removed.

Specifications for XtraDrive Regenerative Resistors

Applicable XtraDrive		Specifications for Regenerative Resistor Mounted in a XtraDrive		Min. Allowable Resistance (Ω)
		Resistance (Ω)	Capacity (W)	
Single-phase 200V	XD-01	-	-	40
	XD-02			
	XD-04			
	XD-08	50	60	40
	XD-15	25	140	20
Three-phase 400V	XD-05	108	70	73
	XD-10			
	XD-20	45	140	44
	XD-30			

Examples of External Regenerative Resistors

Manufacturer Model	Specifications	Manufacturer
RH120	70W, 1 to 100 Ω	Iwaki Wireless Research Institute
RH150	90W, 1 to 100 Ω	
RH220	120W, 1 to 100 Ω	
RH300C	200W, 1 to 10 k Ω	
RH500	300W, 10 to 30 Ω	

* Set the resistance of the regenerative resistor to higher than the minimum allowable resistance of the XtraDrive.

■ Product Name Configurations

RH120 (N) 10 Ω J
1 2 3

<u>1</u> Model	N indicates non-inductive windings
<u>2</u> Resistance	-
<u>3</u> Resistor Tolerance	K: $\pm 10\%$ J: $\pm 5\%$ H: $\pm 3\%$

Specifications

Resistor Tolerance	K: $\pm 10\%$, J: $\pm 5\%$, H: $\pm 3\%$
Resistor Temperature Characteristics	± 400 PPM/ $^{\circ}\text{C}$ (Up to 20Ω), ± 260 PPM/ $^{\circ}\text{C}$ (20Ω or higher)
Withstand Voltage	ΔR at 200 VAC/1min: $\pm(0.1\% + 0.05 \Omega)$
Insulation Resistance	500 VDC, $20 \text{ M}\Omega$ or higher
Short-term Overload	ΔR with 10 times the rated power applied for 5 s: $\pm(2\% + 0.05 \Omega)$
Service Life	ΔR in 1000 hours at rated 90 minutes ON and 30 minutes OFF: $\pm(5\% + 0.05 \Omega)$
Inflammability	Fire does not occur with 10 times the rated power applied for 1 min.
Ambient Temperature Range	-25 to $150 \text{ }^{\circ}\text{C}$

Dimensional Drawings

RH120,150,220 Lead wire: L=300(11.81)

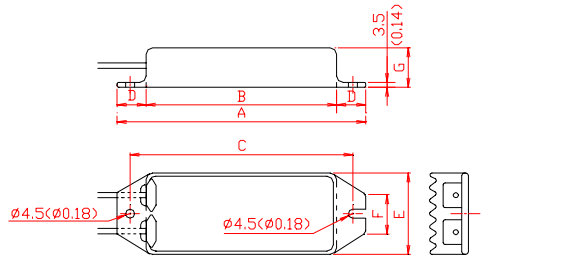

	Rated Power	Resistance Range	Unit (mm) (in)						
			A	B	C	D	E	F	G
RH120	70W	1Ω to 100Ω	182 (7.17)	150 (5.91)	172 (6.77)	16 (0.63)	42 (1.65)	22 (0.87)	20 (0.79)
RH150	90W	1Ω to 100Ω	212 (8.35)	180 (7.09)	202 (7.95)	16 (0.63)	44 (1.73)	24 (0.94)	30 (1.18)
RH220	120W	1Ω to 100Ω	230 (9.06)	200 (7.87)	220 (8.66)	15 (0.59)	60 (2.36)	24 (0.94)	20 (0.79)

RH 220B

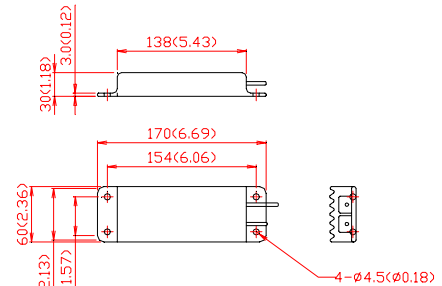

Lead wire: L=500(19.69)
 Rated power: 120W
 Resistance range: 1Ω to $100\text{k}\Omega$

RH 300C

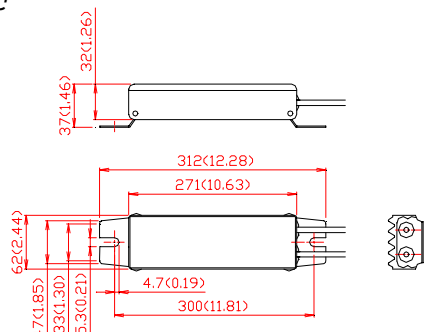

Lead wire: L=300(11.81)
 Rated power: 200W
 Resistance range: 1Ω to $10\text{k}\Omega$

RH 500

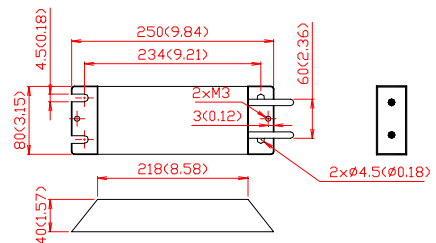

Lead wire: L=450(17.72)
 Rated power: 300W
 Resistance range: 1Ω to $30\text{k}\Omega$

C.3. DC Reactors for Power Supplies Designed for Minimum Harmonics

If necessary for power supplies designed for minimum harmonics, connect a DC reactor between the (+)1 and (+)2 terminals of XtraDrive main circuits. Select a DC reactor that matches the ratings of the XtraDrive from among those listed in table.

DC Reactor Specifications

Applicable XtraDrive		Reactor Specifications		Reactor Model
		Impedance (mH)	Rated Current (A)	
Single-phase 200V	XD-01	40.0	0.85	X5071
	XD-02	20.0	1.65	X5070
	XD-04	10.0	3.3	X5069
	XD-08	4.0	5.3	X5079
Three-phase 200V	XD-10	2.0	4.8	X5061
	XD-20	1.5	8.8	X5060
	XD-30	1.0	14.0	X5059
Three-phase 400V	XD-05	4.7	1.5	X5074
	XD-10	3.3	4.5	X5075
	XD-15			
	XD-20	2.2	8.6	X5076
XD-30				

■ **Dimensional Drawings**

Reactor Model	Dimensions mm (in)									Approximate Mass kg (lb)
	A	B	C	D	E	F	G	φH	φI	
X5071	35 (1.38)	52 (2.05)	80 (3.15)	95 (3.74)	30 (1.18)	40 (1.57)	45 (1.77)	4	4.3 (0.17)	0.5 (1.102)
X5070	40 (1.57)	59 (2.32)	100 (3.94)	120 (4.72)	35 (1.38)	45 (1.77)	50 (1.97)	4	4.3 (0.17)	0.8 (1.764)
X5069	40 (1.57)	59 (2.32)	105 (4.13)	125 (4.92)	45 (1.77)	60 (2.36)	65 (2.56)	4	5.3 (0.21)	1.0 (2.205)
X5079	50 (1.97)	74 (2.91)	125 (4.92)	140 (5.51)	35 (1.38)	45 (1.77)	60 (2.36)	5	4.3 (0.17)	1.2 (2.65)
X5078	50 (1.97)	74 (2.91)	125 (4.92)	155 (6.1)	60 (2.36)	70 (2.76)	80 (3.15)	5	5.3 (0.21)	2.0 (4.41)
X5061	35 (1.38)	52 (2.5)	80 (3.15)	95 (3.74)	35 (1.38)	45 (1.77)	50 (1.97)	4	4.3 (0.17)	0.5 (1.102)
X5060	40 (1.57)	59 (2.32)	105 (4.13)	125 (4.92)	45 (1.77)	60 (2.36)	65 (2.56)	4	4.3 (0.17)	1.0 (2.205)
X5059	50 (1.97)	74 (2.91)	125 (4.92)	155 (6.1)	60 (2.36)	70 (2.76)	80 (3.15)	5	5.3 (0.21)	1.1 (2.43)
X5074	30 (1.18)	47 (1.85)	70 (2.76)	85 (3.35)	28 (1.10)	38 (1.50)	45 (1.77)	4	4.3 (0.17)	0.3 (0.661)
X5075	40 (1.57)	59 (2.32)	100 (3.94)	120 (4.72)	40 (1.57)	50 (1.97)	55 (2.17)	4	4.3 (0.17)	0.9 (1.984)
X5076	50 (1.97)	74 (2.91)	125 (4.92)	140 (5.51)	35 (1.38)	45 (1.77)	60 (2.36)	5	4.3 (0.17)	1.1 (2.43)

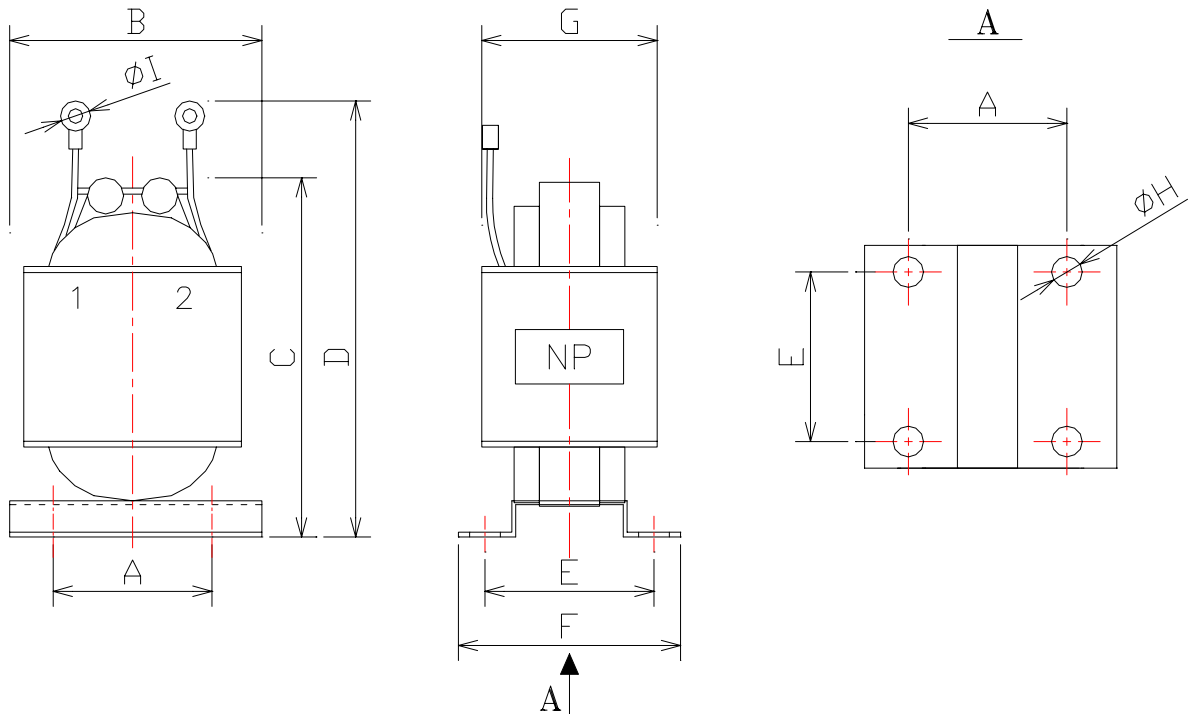

C.4. Brake Power Supplies

Brake power supplies are available for 200V inputs for servomotors with brakes.

- 200 V input: LPSE-2H01

■ Dimensional Drawings

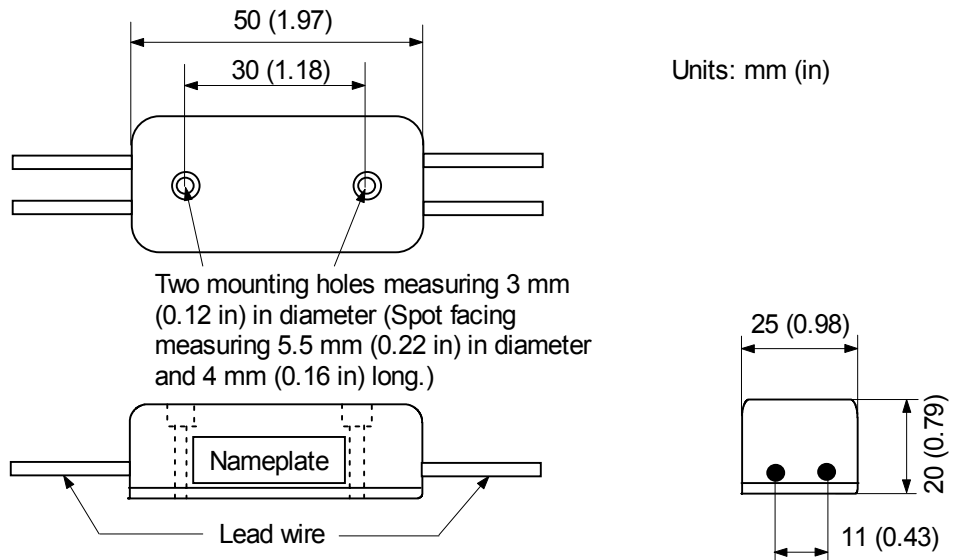

■ Specifications

- Lead wire length: About 500 mm (19.69 in) each
- Max. ambient temperature: 60 C
- Lead wires: Color coded

AC Input	Brake End
Yellow/White	Red/Black

■ Internal Circuit

The following shows internal circuit for brake power supply. While it is possible to switch either the AC or DC side of the power supplies, it is normally safer to switch the AC side.

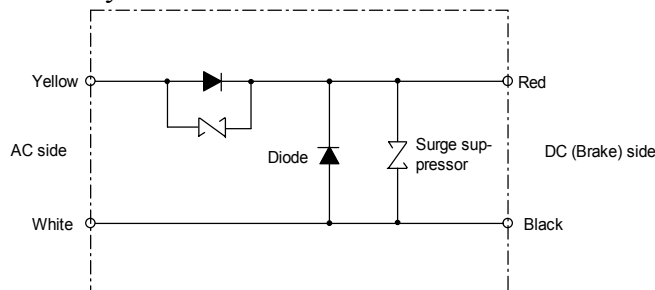

* When switching on the DC side, install a surge suppressor near the brake coil to prevent damage to the coil from voltage surges due to DC-side switching.

C.5. Surge Suppressor

Recommended to install surge suppressor that absorbs surge voltage generated when the magnetic coil is OFF. This prevents faulty operation or damage to electronic circuits near the magnetic contactors or switches.

C.6. Magnetic Contactor

A magnetic contactor turns ON and OFF the servo. Be sure to attach a surge suppressor to the excitation coil of the magnetic contactor.

Select a magnetic contactor based on the current capacity of the XtraDrive. For multiply servo systems, select a contactor based on total current capacity.

C.7. Variable Resistor for Speed Setting

A variable resistor provides speed references by applying speed reference voltage from the external power supply across CN1 pins 1 and 5 as well as 1 and 6.

■ Connection to an External Power Supply

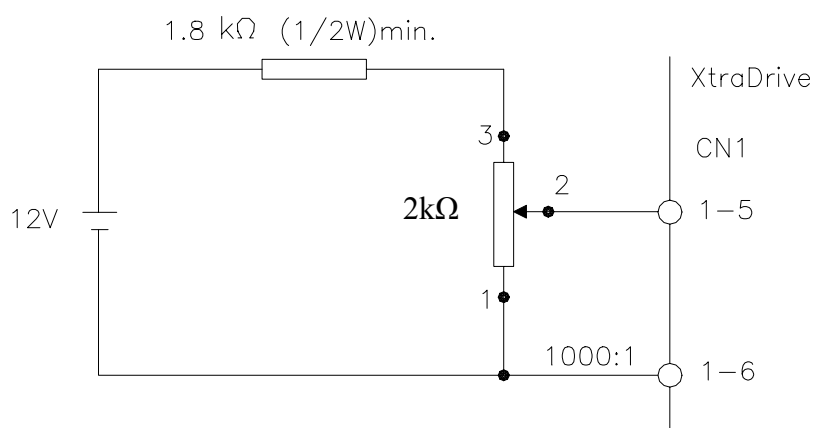

C.8. CN1 I/O Signal Connector

CN1 connector is required to connect the host controller to XtraDrive. It comprised of a connector and a case.

YET P/N of Connector	Connector Parts	
	Connector	Case
	Model	Model
4J4003	10150-3000VE *	10350-52A0-008 *

* Manufactured by Sumitomo 3M Co.

C.9. Connecting Pulse A/B Encoder without C Pulse (Index Pulse)

OEM Encoder Cable

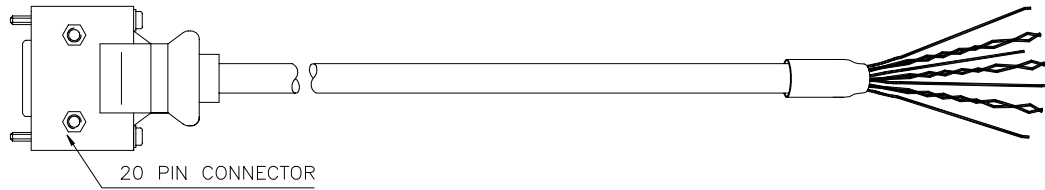

XtraDrive Side Pin Number (20-pin connector)	Signal Name	Wire Color	Remarks
1,2,3	PG GND	Black	
4,5,6	PG +5V	Red	Twisted Pair
		White	
14	PC	Green	Twisted Pair
15	/PC	White	
16	PA	Blue	Twisted Pair
17	/PA	White	
18	PB	Yellow	Twisted Pair
19	/PB	White	
FG	Connector Shield	Yellow/Green	

In case of using an A/B encoder without C pulse:

- Connect signal PC (Green Wire) directly to +5V terminal (together with Red-White PG +5V wires)
- Connect signal /PC (White wire from Green-White pair) directly to GND terminal (together with Black wire)

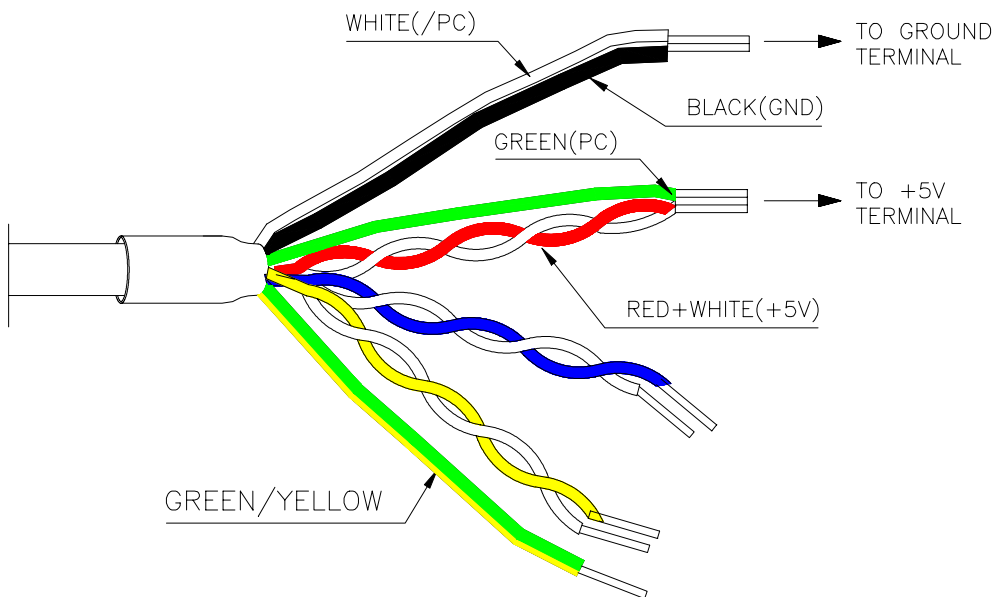

C.10. Absolute Encoder Battery

When the power supply of an absolute encoder is OFF, a data backup battery is required. Customers can install one of the absolute encoder batteries shown below.

■ Battery Installed at the Absolute Encoder Cable End

Model: ER6V (Lithium battery by Toshiba Battery Co. Ltd)

3.6V 2000 mAh

YET P/N: 704004



■ Battery Installed at the XtraDrive End (CN1 Connector)

Connect a lithium battery with following characteristics to XtraDrive using CN1 connector:

2000 mAh

3.6V

Contact No.	Contact Name
21	Battery +
22	Battery -

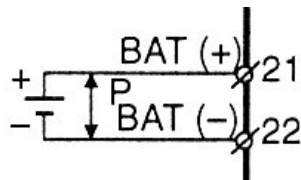

↑P represents twisted pair.

C.11. Cables for Connecting PC to XtraDrive

C.11.1. RS-232 Communication Cable

Cable Configuration

D-Sub 9-pin connector

Plug: 77SDE-09S

Shell: 17JE-09-H1C

Amphenol Ltd.

Half-pitch 14-pin connector

Plug: 10114-3000VE

Shell: 10314-52A0-008

Sumitomo 3M Ltd.

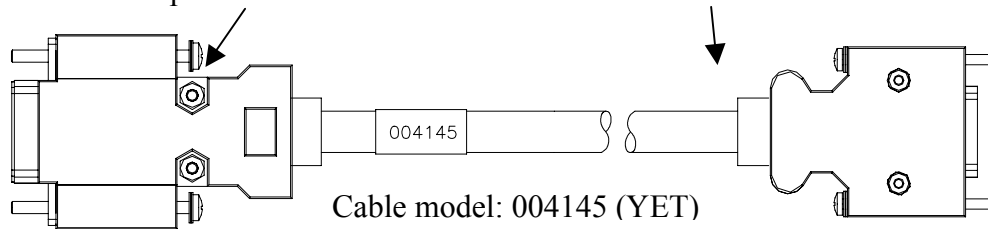

Communication Specifications

The communication specifications are as follows:

- Baud Rate: up to 19200 bps
- Number of Bits:
 - Start: 1 bit
 - Data: 7 bits
 - Stop: 1 bit
 - Parity: 1 bit (even)
- Synchronization Method: Start-Stop
- XON/XOFF Control: None
- Shift Control: None
- Communication Method: Semi-duplex

Connection Circuits

- With the Standard RS-232C Port

Maximum cable length is 2 m (6.56 ft). In this case, the connection circuits are follows:

XtraDrive end (14-pin CN3) RS-232C port (9-pin PC end)

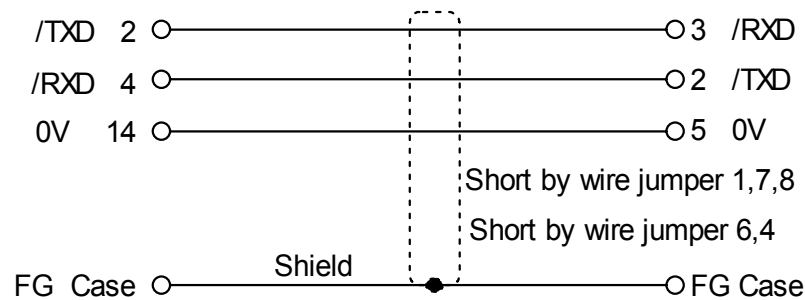

- With RS-422A Port

XtraDrive can also be connected to an RS-422A port.

In this case, the connection circuit is as follows:

- Transmission Distance: 30 m (98.4 ft)
- Transmission System: RS-422A

XtraDrive end (CN3) RS-422A port (PC end)

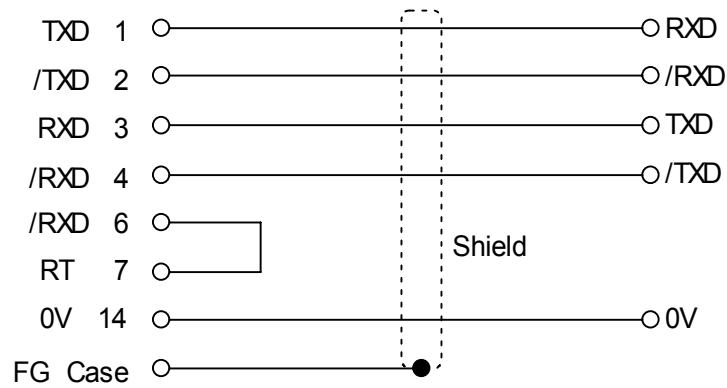

- Terminal Arrangement at XtraDrive End

Connector Pin Numbers and Signal Names

Pin No.	Signal Name	Signal Circuit Name	Signal Direction
1	TXD	Transmit data (not inverted)	P ¹ ← S ²
2	/TXD	Transmit data (inverted)	P ← S
3	RXD	Receive data (not inverted)	P → S
4	/RXD	Receive data (inverted)	P → S
5	OPH	Reserved pin	-
6	/RXD	Short pins 6 and 7 to insert a 220Ω terminating resistance between RXD and /RXD	
7	RT		
8	TXD	Transmit data (not inverted)	P ← S
9	/TXD	Transmit data (inverted)	P ← S
10	RXD	Receive data (not inverted)	P → S
11		Reserved pin	# ³
12		Reserved pin	# ³
13	5VPP	Reserved pin	-
14	GND		-

- * 1. P: Personal computer
- * 2. X: XtraDrive
- * 3. #: Reserved terminal (leave open)

C.12. Connecting Regenerative Resistors

The method for connecting regenerative resistors is shown below.

Disconnect the wire between the servo amplifier's B2 and B3 terminals and connect an external regenerative resistor between the B1 and B2 terminals.

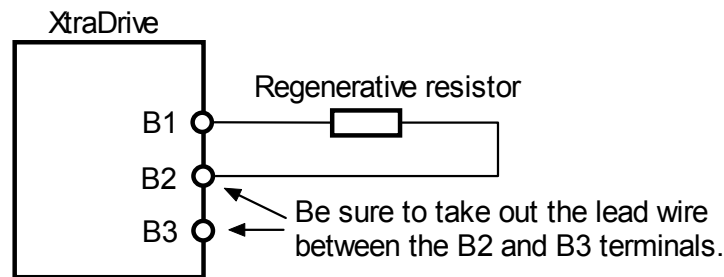

*The user must provide the regenerative resistor.

■ Calculating the Regenerative Power Capacity

Simple Calculation Method

When driving a servomotor normally along the horizontal axis, check the external regenerative resistor requirements using the calculation method shown below.

Servo Amplifiers with Capacity of 400W or Less

Servo amplifiers with a capacity of 400W or less do not have built-in regenerative resistors. The energy that can be absorbed by capacitors is shown in the following table. If the rotational energy in the servo system exceeds these values, then connect a regenerative resistor externally.

Voltage	Applicable Servo Amplifiers	Regenerative Energy that Can be Processed (joules)	Comments
200V	XD-P3-**, -P5-**	18.5	Value when the input voltage is 200V AC
	XD-01-** to -04-**	37.1	

Calculate the rotational energy in the servo system using the following equation:

$$E_S = \frac{J \times (N_M)^2}{12566} \text{ Joules}$$

Where: $J = J_M + J_L$

J_M : Servomotor rotor inertia ($\text{kg}\cdot\text{m}^2$) ($\text{oz}\cdot\text{in}\cdot\text{s}^2$)

J_L : Motor axis conversion load inertia ($\text{kg}\cdot\text{m}^2$) ($\text{oz}\cdot\text{in}\cdot\text{s}^2$)

N_M : Rotation speed of the servomotor (rpm)

Servo Amplifier Capacity of 0.8 to 3.0kW

Servomotors with a capacity of 500W to 3kW have built-in regenerative resistors. The allowable frequencies for just the servomotor during acceleration/deceleration operation, in the run cycle from 0 to the maximum rotation speed to 0, are summarized in the following table.

Convert the data into the values obtained with actual rotation speed used and load inertia to determine whether an external regenerative resistor is needed.

Voltage	Series	Allowable Frequencies in Regeneration Mode (r/min)								
	Capacity Symbol	03	05	08	09	10	13	15	20	30
200V	SGMAH	—	—	89	—	—	—	—	—	—
	SGMPH	—	—	29	—	—	—	17	—	—
	SGMGH-□A□A		34	—	13	—	10	—	12	8
	SGMSH	—	—	—	—	39	—	31	48	20
400V	SGMGH	—	42	—	15	—	10	—	12	8
	SGMSH	—	—	—	—	47	—	31	48	20
	SGMUH	—	—	—	—	27	—	19	—	13

Operating Conditions for Allowable Regenerative Frequency Calculation

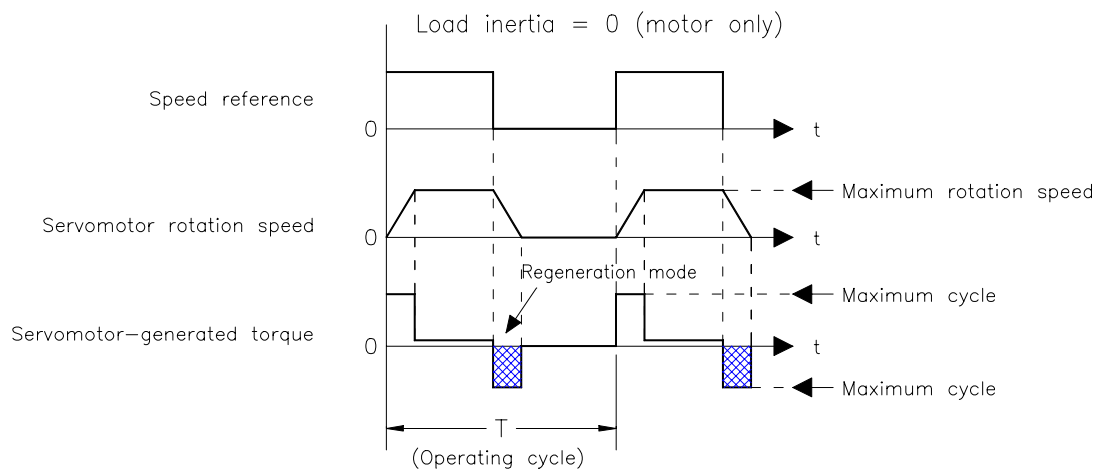

$$\text{Allowable frequency} = 1/T \text{ (r/min)}$$

Use the following equation to calculate the allowable frequency for regeneration mode operation.

$$\text{Allowable frequency} = \frac{\text{Allowable frequency for servomotor only}}{(1 + n)} \times \left(\frac{\text{Max. rotation speed}}{\text{Rotation speed used}} \right)^2 \frac{\text{Cycles}}{\text{Minute}}$$

Where: $n = J_L/J_M$

J_L : Motor axis conversion load inertia [oz·in·s² (kg·m²)]

J_M : Servomotor rotary inertia [oz·in·s² (kg·m²)]

■ Regenerative Energy Calculation Method

This section shows the procedure for calculating the regenerative resistor capacity when acceleration and deceleration operation is as shown in the following diagram.

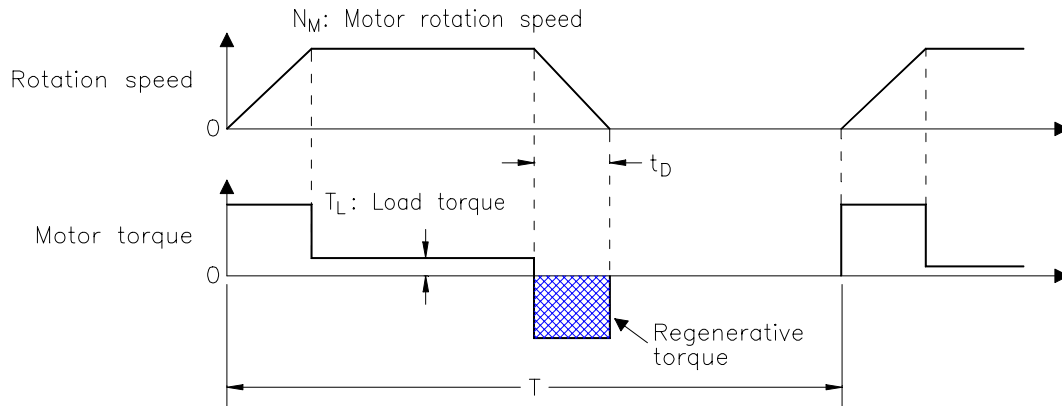

Calculation Procedure

The procedure for calculating the capacity is as follows:

Step	Procedure	Units [in. (mm)]	Equation
1	Find the rotational energy of the servo system (E_S).	$E_S =$ [Joules] = [J]= [oz·in·s ² (kg·m ² ·s ²)] $J_L =$ J $J_M =$ J $N_M =$ rpm	$E_S = \frac{(J_L + J_M) \times N_M^2}{182}$ Where: $N_M =$ Motor speed $J_L =$ Load Inertia $J_M =$ Motor Inertia
2	Find the energy consumed by load system loss (E_L) during the deceleration period (t_D).	$\tau_L =$ oz·in (N·m) $E_L =$ Joules = J $N_M =$ rpm $t_D =$ s	$E_L = \frac{\pi}{60} (N_M \times \tau_L \times t_D)$ □Where: $\tau_L =$ Motor torque
3	Calculate the energy lost (E_M) from servomotor winding resistance.	$t_D =$ s = deceleration stopping time $E_M =$ Joules = J	$E_M =$ (Value from the “Servomotor Winding Resistance Loss” graph below) $\times t_D$
4	Calculate the servo amplifier energy (E_C) that can be absorbed.	$E_C =$ Joules = J	$E_C =$ Value from the “Absorbable Servo Amplifier Energy” graph below.
5	Find the energy consumed by the regenerative resistor (E_K).	$E_K = E_S = E_L = E_M = E_C =$ Joules = J	$E_K = E_S - (E_L + E_M + E_C)$
6	Calculate the required regenerative resistor capacity (W_K).	$W_K =$ W $E_K =$ Joules = J $T =$ s	$W_K = \frac{E_K}{0.2 \times T}$ Where: T = Time

* 1. The “0.2” in the equation for calculating W_K is the value for when the regenerative resistor’s utilized load ratio is 20%.

If the previous calculation determines that the amount of regenerative power (W_{Wk}) that can be processed by the built-in resistor is not exceeded, then an external regenerative resistor is not required.

If the amount of regenerative power that can be processed by the built-in resistor is exceeded, install an external regenerative resistor for the capacity obtained from the above calculation.

If the energy consumed by load system loss (in step 2 above) is unknown, then perform the calculation using $E_L = 0$.

When the operation period in regeneration mode is continuous, add the following items to the above calculation procedure in order to find the required capacity (W) for the regenerative resistor.

- Energy for continuous regeneration mode operation period: E_G (joules)
- Energy consumed by regenerative resistor: $E_K = E_S - (E_L + E_M + E_C) + E_G$
- Required capacity of regenerative resistor: $W_K = E_K / (0.2 \cdot T)$
Here, $E_G = (2\pi/60) N_{MG} \times \tau_G \cdot t_G$
- τ_G : Servomotor's generated torque [oz·in (N·m)] in continuous regeneration mode operation period.
- N_{MG} : Servomotor rotation speed (rpm) for same operation period as above.
- t_G : Same operation period (s) as above.

Servo Amplifier's Absorbable Energy

The following diagrams show the relationship between the servo amplifier's input power supply voltage and its absorbable energy.

- XtraDrive for 200V motor

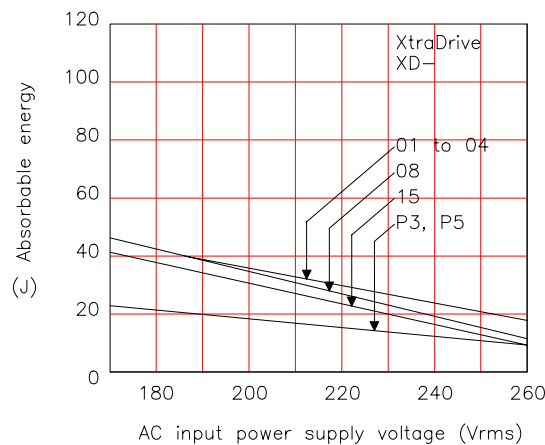

- XtraDrive for 400V motor

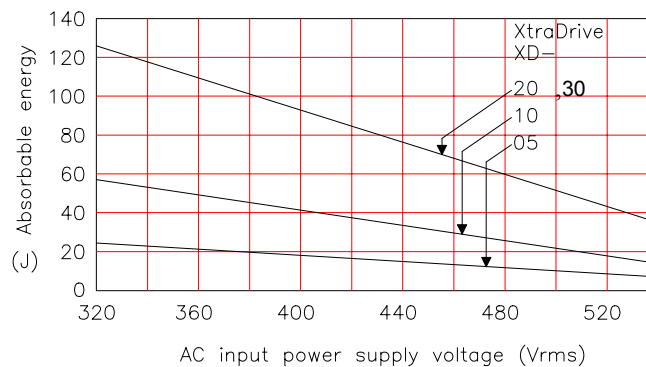

C.13. Connecting Yaskawa Option Board

XtraDrive supports Yaskawa option boards. When connecting the Yaskawa option board, XtraDrive acts as an SGDh servo amplifier, includes control loops, which are not NCT (standard control loop of XtraDrive).

Note: XtraDrive's digital I/O allocation input (Pn50A – Pn510) default is different than SGDh default.

C.13.1. Attaching the Option Board

XtraDrive parameter settings

1. Set Pn000.1=1 for Option Board detection.

Set Pn191.3

2. Restart XtraDrive

Note: These settings done automatically by selecting “Yaskawa Option Board” during wizard.

Parameter	Dig.	Name	Setting	Description	Default
Pn191	3	Option Board	0	Option board enabled	0
		Enable	1	Option board ignored	

Mounting the Option Board to XtraDrive

1. Turn XtraDrive power supply off.
2. Remove the connector cover from the CN10 connector on the XtraDrive.
3. Insert the lower two mounting notches into the mounting holes at the bottom right of the XtraDrive.
4. Push the Option Board, inserting the upper mounting notches of the board into the upper mounting holes on the right side of the XtraDrive.
5. For grounding, connect the ground wire of the board to the point marked “G” on the XtraDrive.

C.13.2. Detaching the Option Board

1. Turn XtraDrive power supply off.
2. Disconnect the ground wire of the board from the XtraDrive.
3. Push the upper mounting notch (single) of the board out off the upper mounting holes on the right side of the XtraDrive.
4. Turn XtraDrive power supply on.
5. Alarm A.E7 will appear. To clear the alarm executes Fn014 (option unit detection result clear), in the auxiliary function mode, and then cycle the power. See 7.2.13
6. Set Pn000.1 to the required control method and reset the XtraDrive.

Appendix D. List of Parameters

This appendix lists the parameters, switches, and input signal selections, out put signal selections, auxiliary functions, and monitor modes for XtraDrive servo amplifiers.

D.1.	Parameters	D-2
D.2.	Switches	D-7
D.3.	Input Signal Selections	D-11
D.3.1.	Home Switches	D-12
D.3.2.	Extended input signal selection.	D-12
D.4.	Output Signal Selections.....	D-13
D.4.1.	Extended Output Signal Selection	D-13
D.5.	Auxiliary Functions	D-14
D.6.	Monitor Modes.....	D-14

D.1. Parameters

The following list shows parameters and their settings.

Category	Parameter Number	Name	Unit	Setting Range	Default Setting	Reference
Function Selection Parameters	Pn000*	Function Selection Basic Switches	—	—	0x00D0	5.1.1, 5.3.5
	Pn001*	Function Selection Application Switches 1**	—	—	0000	5.1.2, 5.4.2, 5.5.7
	Pn002*	Function Selection Application Switches	—	—	0000	5.2.8, 5.2.9, 5.7.2
	Pn003	Function Selection Application Switches 3	—	—	0002	6.4
	Pn006	Function Selection Application Switches 3	—	—	0000	6.4
	Pn007	Function Selection Application Switches 3	—	—	0000	6.4
Gain Parameters	Pn100	Speed Loop Gain	Hz	1 to 2000	40	6.2.2, 6.2.7, 6.2.10
	Pn101	Speed Loop Integral Time Constant	0.01ms	15 to 51200	2000	
	Pn102	Position Loop Gain	s ⁻¹	1 to 2000	40	6.2.10
	Pn103	Inertia Ratio	%	0 to 10000	300	6.2.6, 6.3.1, 6.3.5
	Pn109	Feed-Forward (Speed control)	%	0 to 100	0	6.2.2
	Pn110*	Online Autotuning Switches	—	—	0010	6.3.4

* After changing this parameter, cycle the main circuit and control power supplies to enable the new settings.

** The multi-turn limit is valid only when parameter Pn002.2 Absolute Encoder Usage is set to "2". The value will be processed in the range of "+32767 to -32768" for other settings even if the value is changed. There is no need to change the multi-turn limit except for in special cases. Be careful not to change the setting unless necessary.

Category	Parameter Number	Name	Unit	Setting Range	Default Setting	Reference
Motor parameters	Pn190*	Motor selection switch	--	--	0000	5.8
	Pn191*	Motor selection switch	--	--	0000	5.8
	Pn192*	Pulses number of A quad B encoder (Low)	Pulses/rev	0-9999	2048	5.8
	Pn193*	Pulses number of A quad B encoder (High)	Pulse*10000/Rev	0-419	0	5.8
	Pn199*	Encoder counts per Scale Pitch of linear motor	Counts/Scale Pitch	1-256	1	
Gain parameters	Pn1A0	Global gain factor (Tightness)	%	0-500	60	6.3.3
	Pn1A2	Speed feedback filter	0.01ms	30-3200	40	6.3.5
	Pn1A4	Torque filter (low pass)	0.01ms	0-2500	20	6.3.5
	Pn1A5	Torque filter (second order)	0.1%	0-1000	0	6.3.5
	Pn1A7	Integral mode switch	--	--	1121	6.3.8
	Pn1A9	Integral feedback gain	Hz	0-500	40	6.3.5
Pn1AA	Proportional feedback gain	Hz	0-500	40	6.3.3	
	Pn1AB	Supplementary proportional feedback gain	Hz	0-500	30	6.3.3

Category	Parameter Number	Name	Unit	Setting Range	Default Setting	Reference
Gain Parameters	Pn1AC	Speed feedback gain	Hz	0-2000	80	6.3.3
	Pn1AD	Acceleration feedback gain	%	0-500	0	6.3.3
	Pn1AE	Acceleration feedback filter	0.01ms	0-2500	300	6.3.9
	Pn1AF	Feed forward gain	%	0-200	0	6.3.3
	Pn1B5	Maximum variable gain	%	100-1000	160	6.3.7
	Pn1BB	Feed forward compensation	Hz	10-2000	2000	6.3.4
	Pn1BC	Filter on command acceleration	0.01ms	0-2500	300	6.3.4
	Pn1BD	Reduction of vibrations due to system flexibility.	Hz	10-2000	2000	6.3.4
	Pn1BF	Integral switch advance	--	1-15	3	6.3.8
	Pn1C0	Integral offset averaging time	ms	0-25	0	6.3.7
Pn1C1	Integral switch advance	125us	0-8	3		
Position Parameters	Pn200*	Position Control Reference Selection Switches	—	—	0000	5.2.2
	Pn201*	PG Divider (rotary motor)	p/r	0 to 65635	2048	5.2.3
	Pn202*	Electronic Gear Ratio (Numerator)	—	1 to 65535	4	5.2.5
	Pn203*	Electronic Gear Ratio (Denominator) (See note 3).	—	1 to 65535	1	5.2.5
	Pn205*	Multi-Turn Limit Setting ²	rev	0 to 65535	65535	5.7.2
	Pn216	Command smoothing	0.1ms	0-65535	0	6.3.4
Linear Motor Position parameter	Pn281*	PG Divider	Counts / Scale Pitch	1-256	1	
Serial communication command	Pn2A2*	Work speed default (low)	Speed units	0-65535	0	5.9.1.2
	Pn2A3*	Work speed default (high)	Speed units* 65536	0-256	0	5.9.1.2
	Pn2A4*	Work acceleration default (low)	Acceleration units	0-65535	0	5.9.1.2
	Pn2A5*	Work acceleration default (high)	Acceleration units* 65536	0-256	0	5.9.1.2
	Pn2A6*	Work jerk smoothing time default	μs	0-63999	0	5.9.1.2
	Pn2A8*	Quick stop deceleration (low)	Acceleration units	0-65535	65535	5.9.1.2
	Pn2A9*	Quick stop deceleration (high)	Acceleration units* 65536	0-256	256	5.9.1.2
	Pn2B0*	Position units ratio numerator (low)	--	1-65535	1	5.9.1.1
	Pn2B1*	Position units ratio numerator (high)	--	0-16383	0	5.9.1.1
	Pn2B2*	Position units ratio denominator (low)	--	1-65535	1	5.9.1.1
	Pn2B3*	Position units ratio denominator (high)	--	0-16383	0	5.9.1.1
	Pn2B4*	Speed units ratio numerator (low)	--	1-65535	1	5.9.1.1
	Pn2B5*	Speed units ratio numerator (high)	--	0-16383	0	5.9.1.1
	Pn2B6*	Speed units ratio denominator (low)	--	1-65535	1	5.9.1.1
	Pn2B7*	Speed units ratio denominator (high)	--	0-16383	0	5.9.1.1

Category	Parameter Number	Name	Unit	Setting Range	Default Setting	Reference
Serial communication command	Pn2B8*	Acceleration units ratio numerator (low)	--	1-65535	1	5.9.1.1
	Pn2B9*	Acceleration units ratio numerator (high)	--	0-16383	0	5.9.1.1
	Pn2BA*	Acceleration units ratio denominator (low)	--	1-65535	1	5.9.1.1
	Pn2BB*	Acceleration units ratio denominator (high)	--	0-16383	0	5.9.1.1
	Pn2C0	Motion end window	User position units	0-250	7	5.9.1.2
	Pn2C1	Torque slope	0.1% of rated torque/ ms	1-24000	24000	5.9.2
	Pn2C4	Synchronize window for pulse train	User position units	0-250	7	Note*
	Pn2C5	Zero speed when find hard home	Speed units	0-32000	2	5.9.3
	Pn2C6	Communication switch selection	Null	0-1	1	
	Pn2C7*	Home switch selection	--	--	0008	5.9.3
	Pn2C8	Auto tuning – Time between movements	ms	200-2000	400	5.9.5
	Pn2C9	Auto tuning – Speed of movement	% of maximum speed	0-100	50	5.9.5
	Pn2CA	Auto tuning – Acceleration time	ms	1-1000	50	5.9.5
	Pn2CB	Auto tuning – Plateau time of movement	ms	0-1000	50	5.9.5
	Pn2CC*	Auto start user program	--	0-99	0	5.10
	Pn2D0	Reserved	--	--	-	-
	Pn2D1*	Expand input signal selection 2	--	--	8887	5.9.4
Pn2D2*	Expand output signal selection 1	--	--	0021	5.9.4	
Speed Parameters	Pn300	Speed Reference Input Gain	0.01V/ rated speed	150 to 3000	600	5.2.1
	Pn301	Speed 1 (rotary motor)	rpm	0 to 10000	100	5.2.6
	Pn302	Speed 2	rpm	0 to 10000	200	5.2.6
	Pn303	Speed 3	rpm	0 to 10000	300	5.2.6
	Pn304	Jog Speed	rpm	0 to 10000	500	5.3.2
	Pn305	Soft Start Acceleration Time	ms	0 to 10000	0	6.2.2
	Pn306	Soft Start Deceleration Time	ms	0 to 10000	0	6.2.2
	Pn307	Speed Reference Filter Time Constant	0.01ms	0 to 65535	40	—
	Pn308	Speed Feedback Filter Time Constant	0.01ms	0 to 65535	0	—
Linear Motor Speed Parameters	Pn380	Speed1	mm/s	0-5000	10	
	Pn381	Speed2	mm/s	0-5000	20	
	Pn382	Speed3	mm/s	0-5000	30	
	Pn383	Jog Speed	mm/s	0-5000	40	

Category	Parameter Number	Name	Unit	Setting Range	Default Setting	Reference
Torque Parameters	Pn400	Torque Reference Input Gain	0.1V/rated torque	10 to 100	30	5.2.7
	Pn401	Torque Reference Filter Time Constant	0.01ms	0 to 65535	100	6.2.2
	Pn402	Forward Torque Limit	%	0 to 800	800	5.1.3
	Pn403	Reverse Torque Limit	%	0 to 800	800	5.1.3
	Pn404	Forward External Torque Limit	%	0 to 800	100	5.1.3
	Pn405	Reverse External Torque Limit	%	0 to 800	100	5.1.3
	Pn406	Emergency Stop Torque	%	0 to 800	800	5.1.2
	Pn407	Speed Limit during Torque Control	rpm	0 to 10000	10000	5.2.7
	Pn408	Torque Function Switches	—	—	0000	6.2.9
	Pn409	Notch Filter Frequency	Hz	50 to 2000	2000	6.2.9
	Pn40A	Notch Filter width	Hz	70 to 1000	70	6.2.9
Linear Motor Torque Parameters	Pn480	Speed limit during torque control	mm/s	0-5000	5000	
	Pn483	Forward force limit	% of rated force	0-800	10	
	Pn484	Reverse force limit	% of rated force	0-800	10	
Sequence Parameters	Pn500	Positioning Completed Width	ref. units	0 to 250	7	5.5.3
	Pn501	Zero Clamp Level	rpm	0 to 10000	10	5.4.3
	Pn502	Rotation Detection Level	rpm	1 to 10000	20	5.5.5
	Pn503	Speed Coincidence Signal Output Width	rpm	0 to 100	10	5.5.4
	Pn504	NEAR Signal Width	ref. units	1 to 250	7	5.5.8
	Pn505	Overflow Level	256 ref. units	1 to 32767	1024	6.2.1
	Pn506	Brake Reference Servo OFF Delay Time	10ms	0 to 50	0	5.4.4
	Pn507	Brake Reference Output Speed Level	rpm	0 to 10000	100	5.4.4
Sequence Parameters	Pn508	Timing for Brake Reference Output during Motor Operation	10ms	10 to 100	50	5.4.4
	Pn509	Momentary Hold Time	ms	20 to 1000	20	5.5.9
	Pn50A*	Input Signal Selections 1	—	—	8881	5.3.3
	Pn50B*	Input Signal Selections 2	—	—	8848	5.3.3
	Pn50C*	Input Signal Selections 3	—	—	8888	5.3.3
	Pn50D*	Input Signal Selections 4	—	—	8888	5.3.3
	Pn50E*	Output Signal Selections 1	—	—	3000	5.3.4
	Pn50F*	Output Signal Selections 2	—	—	0000	5.3.4
	Pn510*	Output Signal Selections 3	—	—	0000	5.3.4
	Pn511	Reserved parameter (Do not change).	—	—	8888	—
Pn512*	Output Signal Reversal Settings	—	—	0000	5.3.4	
Linear Motor Sequence Parameters	Pn580	Zero clamp level	mm/s	0-5000	10	
	Pn581	Motion detection level	mm/s	1-5000	20	
	Pn582	Speed coincidence signal output width	mm/s	0-5000	10	
	Pn583	Brake reference output speed level	mm/s	0-5000	100	
Other Parameters	Pn600	Regenerative Resistor Capacity ⁴	10W	0 to capacity ⁵	0	5.6.1
	Pn601	Reserved parameter (Do not change.)	—	0 to capacity ⁵	0	—

* **After changing this parameter, cycle the main circuit and control power supplies to enable the new settings.**

² The multi-turn limit is valid only when parameter Pn002.2 Absolute Encoder Usage is set to "2". The value will be processed in the range of "+32767 to -32768" for other settings even if the value is changed. There is no need to change the multi-turn limit except for in special cases. Be careful not to change the setting unless necessary.

³ The setting of parameter Pn111 is valid only when parameter Pn110.1 is set to 0.

⁴ Normally set to "0". When using an external regenerative resistor, set the capacity (W) of the regenerative resistor.

⁵ The upper limit is the maximum output capacity (W) of the servo amplifier.

Note* Refer to XtraWare User Manual

D.2. Switches

The following list shows the switches and their default settings.

Parameter	Digit Place	Name	Setting	Description	Default Setting
Pn000 Function Selection Basic Switches	0	Direction Selection	0	Sets CCW as forward direction.	0
			1	Sets CW as forward direction (reverse rotation mode).	
	1	Control Method Selection	0	Speed control (analog reference).	D
			2	Torque control (analog reference).	
			3	Internal set speed control (contact reference).	
			4	Internal set speed control (contact reference)/Speed control (analog reference).	
			6	Internal set speed control (contact reference)/Torque control (analog reference).	
			8	Position control (pulse train reference)/Torque control (analog reference).	
			9	Torque control (analog reference)/Speed control (analog reference).	
			A	Speed control (analog reference)/Zero clamp.	
			B	Position control (pulse train reference)/Position control (Inhibit)	
			C	Position control (pulse train)	
D	Serial communication command				
2	Axis Address	0 to F	Sets servo amplifier axis address.	0	
3	Reserved		—	0	
Pn001 Function Selection Application Switches	0	Servo OFF or Alarm Stop Mode	0	Stops the motor by applying dynamic brake (DB).	0
			1	Stops the motor by applying dynamic brake (DB) and then releases DB.	
			2	Makes the motor coast to a stop state without using the dynamic brake (DB).	
	1	Overtravel Stop Mode	0	Same setting as Pn001.0 (Stops the motor by applying DB or by coasting.)	0
			1	Sets the torque of Pn406 to the maximum value, decelerates the motor to a stop, and then sets it to servo lock state.	
			2	Sets the torque of Pn406 to the maximum value, decelerates the motor to a stop, and then sets it to coasting state.	
	2	AC/DC Power Input Selection	0	Not applicable to DC power input: Input AC power supply through L1, L2, and (L3) terminals.	0
			1	Applicable to DC power input: Input DC power supply through (+)1 and (-) terminals.	
	3	Warning Code Output Selection	0	ALO1, ALO2, and ALO3 output only alarm codes.	0
			1	ALO1, ALO2, and ALO3 output both alarm codes and warning codes. While warning codes are output, ALM signal output remains ON (normal state).	
2			Uses absolute encoder as an absolute encoder. Uses multi-turn limit.		

Parameter	Digit Place	Name	Setting	Description	Default Setting
Pn002 Function Selection Application Switches	0	Speed Control Option (T-REF Terminal Allocation)	0	None.	0
			1	Uses T-REF as an external torque limit input.	
			2	Uses T-REF as a torque feed-forward input.	
			3	Uses T-REF as an external torque limit input when P-CL and N-CL are ON.	
	0	Speed Control Option (T-REF Terminal Allocation)	0	None.	
			1	Uses T-REF as an external torque limit input.	
			2	Uses T-REF as a torque feed-forward input.	
			3	Uses T-REF as an external torque limit input when P-CL and N-CL are ON.	
	1	Torque Control Option (V-REF Terminal Allocation)	0	None.	0
			1	Uses V-REF as an external speed limit input.	
	2	Absolute Encoder Usage	0	Uses absolute encoder as an absolute encoder.	0
			1	Uses absolute encoder as an incremental encoder.	
			2	Uses absolute encoder as an absolute encoder. Uses multi-turn limit.	
3	Not used.	0	—	0	
Pn003 Function Selection Application Switches	0	Analog Monitor 1 Torque Reference Monitor	0	Motor speed: 1V/1000rpm.	0
			1	Speed reference: 1V/1000rpm.	
			2	Torque reference: 1V/100%.	
			3	Position error: 0.05V/1 reference units.	
			4	Position error: 0.05V/100 reference units.	
			5	Reference pulse frequency (converted to rpm): 1V/1000rpm.	
			6	Motor speed x 4: 1V/250rpm.	
	7	Motor speed x 8: 1V/125rpm.			
	1	Analog Monitor 2 Speed Reference Monitor	0 to 7	Same as Pn003.0 (see above).	
	2	Not used.	—	—	0
3	Not used.	—	—	0	
Pn006 Gain Application Switches	0	Analog monitor 1.	0	Servo position error: 1V/10 encoder counts	0
			1	Servo position error: 1V/5 user units	
			2	Target speed 1V/500 rpm.	
			3	Target speed after applying command smoothing: 1V/500 rpm	
			4	Torque reference: 10V/Max Torque.	
			5	Motor speed: 1V/500 rpm.	
	1	Analog monitor 1-selection of source parameter	0	Pn003.0 used for analog monitor 1.	0
			1	Pn006.0 used for analog monitor 1.	
	2	Analog monitor 1- magnification of signal.	0-4	0: x1, 1: x10, 2: x100 3: x1/10, 4: x1/100	0
3	Not used.	0	--	0	

Parameter	Digit Place	Name	Setting	Description	Default Setting
Pn007 Gain Application Switches	0	Analog monitor 2.	0	Servo position error: 1V/10 encoder counts	0
			1	Servo position error: 1V/5 user units	
			2	Target speed 1V/500 rpm.	
			3	Target speed after applying command smoothing: 1V/500 rpm	
			4	Torque reference: 10V/Max Torque.	
			5	Motor speed: 1V/500 rpm.	
	1	Analog monitor 2 -selection of source parameter	0	Pn003.1 used for analog monitor 2.	0
			1	Pn007.0 used for analog monitor 2.	
	2	Analog monitor 2 - magnification of signal.	0-4	0: x1, 1: x10, 2: x100 3: x1/10, 4: x1/100	0
			3	Not used.	
Pn080 Linear Motor Commutation Switch	0	Communication sensor switch	0	With commutation sensors	1
			1	Without commutation sensors	
	1	Communication sensor order	0	UVW	1
			1	UWV	
	2	Reserved	--	--	0
3	Reserved	--	--	0	
Pn110 Online Autotuning Switches	0	Online Auto-tuning Method	0	Tunes only at the beginning of operation.	0
			1	Always tunes.	
			2	Does not perform autotuning.	
	1	Speed Feedback Compensation Selection	0	Enabled.	1
			1	Disabled.	
	2	Friction Compensation Selection	0	Friction compensation: Disabled.	0
			1	Friction compensation: Small.	
			2	Friction compensation: Large.	
	3	Reserved	0 - 3	Reserved parameter (Do not change).	0
	Pn190 Motor selection Switches	0	Motor model	0	Yaskawa A quad B model SGM
1				Yaskawa A quad B model SGMP	
2				Non Yaskawa rotary motor	
3				Non Yaskawa linear motor	
1		Encoder type	0	Incremental A quad B encoder	0
			1	Yaskawa absolute A quad B encoder	
2		Encoder selection	0	Yaskawa serial encoder	0
			1	A quad B encoder	
			2	A quad B encoder with commutation sensors (U,V,W)	
3		C- phase mask	0	C phase signal used	0
	1		C phase signal mask		
Pn191 Motor selection Switches	0	Motor phase order	0	Not defined	0
			1	UVW	
			2	UWV	
	1-3	Not used	0	--	0
Pn1A7 Motor selection Switches	0	Integral mode	0	Disable clear integral function (refer to 6.3.8).	1
			1	Enable clear integral function (refer to 6.3.8).	
	1-3	Not used	0	--	0

Parameter	Digit Place	Name	Setting	Description	Default Setting
Pn200 Position Control References Selection Switches	0	Reference Pulse Form	0	Sign + pulse, positive logic.	0
			1	CW + CCW, positive logic.	
			2	A phase + B phase (x1), positive logic.	
			3	A phase + B phase (x2), positive logic.	
			4	A phase + B phase (x4), positive logic.	
			5	Sign + pulse, negative logic.	
			6	CW + CCW, negative logic.	
			7	A phase + B phase (x1), negative logic.	
			8	A phase + B phase (x2), negative logic.	
	9	A phase + B phase (x4), negative logic.			
	1	Error Counter Clear Signal Form	0	Clears error counter when the signal goes high.	0
			1	Clears error counter at the rising edge of the signal.	
			2	Clears error counter when the signal goes low.	
			3	Clears error counter at the falling edge of the signal.	
	2	Clear Operation	0	Clears error counter at the base block.	0
1			Does not clear error counter. (Possible to clear error counter only with CLR signal).		
2			Clears error counter when an alarm occurs.		
3			Clear signal ignore		
3	Filter Selection	0	Reference input filter for line driver signals.	0	
		1	Reference input filter for open collector signals.		
Pn2C6 Communication Switch	0	Check Sum	0	Doesn't use check sum	1
			1	Use check sum	
	1	Not used	---	---	0
	2		1	Normally open	
	3			Home failure	
Pn2D4 Oscillation Canceling Mode Switch	0	Oscillation Canceling Mode	0	OCA is not activate	0
			1	OCA is active	
	1	Not used.	—	—	
	2		—	—	
3	—		—		
Pn408 Torque Control Function Switches	0	Notch Filter Selection	0	Disabled.	0
			1	Uses a notch filter for torque reference.	
	1	Not used.	—	—	
	2		—	—	
3	—		—		

D.3. Input Signal Selections

The following list shows input signal selections and their default settings.

Parameter	Digit Place	Name	Setting	Description	Default Setting
Pn50A	0	Input Signal Allocation Mode	0	Sets the input signal allocation for the sequence to the same one as for the Yaskawa special servo amplifier.	0
			1	Possible to freely allocate the input signals.	
	1	/S-ON Signal Mapping (Servo ON when low.)	0	Inputs from the SI0 (CN1-40) input terminal.	0: SI0
			1	Inputs from the SI1 (CN1-41) input terminal.	
			2	Inputs from the SI2 (CN1-42) input terminal.	
			3	Inputs from the SI3 (CN1-43) input terminal.	
			4	Inputs from the SI4 (CN1-44) input terminal.	
			5	Inputs from the SI5 (CN1-45) input terminal.	
			6	Inputs from the SI6 (CN1-46) input terminal.	
			7	Sets signal ON.	
			8	Sets signal OFF.	
			9	Inputs the reverse signal from the SI0 (CN1-40) input terminal.	
			A	Inputs the reverse signal from the SI1 (CN1-41) input terminal.	
			B	Inputs the reverse signal from the SI2 (CN1-42) input terminal.	
			C	Inputs the reverse signal from the SI3 (CN1-43) input terminal.	
	D	Input the reverse signals from the SI4 (CN1-44) input terminal.			
	E	Inputs the reverse signal from the SI5 (CN1-45) input terminal.			
F	Inputs the reverse signal from the SI6 (CN1-46) input terminal.				
2	/P-CON Signal Mapping (P-control when low.)	0 to F	Same as above.	1: SI1	
3	P-OT Signal Mapping (Overtravel when high.)	0 to F	Same as above.	2: SI2	
Pn50B	0	N-OT Signal Mapping (Overtravel when high.)	0 to F	Same as above.	3: SI3
	1	/ALM-RST Signal Mapping (Alarm reset when low.)	0 to F	Same as above.	4: SI4
	2	/P-CL Signal Mapping (Torque control when low.)	0 to F	Same as above.	5: SI5
	3	/N-CL Signal Mapping (Torque control when low.)	0 to 8	Same as above.	6: SI6

Parameter	Digit Place	Name	Setting	Description	Default Setting
Pn50C	0	/SPD-D Signal Mapping (Internal Set Speed Selection)	0 to F	Same as above.	8: OFF
	1	/SPD-A Signal Mapping (Internal Set Speed Selection)	0 to F	Same as above.	8: OFF
	2	/SPD-B Signal Mapping (Internal Set Speed Selection)	0 to F	Same as above.	8: OFF
	3	/C-SEL Signal Mapping (Control Mode Switching)	0 to F	Same as above.	8: OFF
Pn50D	0	/ZCLAMP Signal Mapping (Zero Clamping)	0 to F	Same as above.	8: OFF
	1	/INHIBIT Signal Mapping (Disabling Reference Pulse)	0 to F	Same as above.	8: OFF
	2	/G-SEL Signal Mapping (Gain Switching)	0 to F	Same as above.	8: OFF
	3	(Reserved)	0 to F	Same as above.	8: OFF

- When Pn50A.0 is set to 0 for the XtraDrive servo amplifier, only the following modes are compatible: Pn50A.1=7, Pn50A.3=8, and Pn50B.0=8.

D.3.1. Home Switches

Parameter	Digit Place	Name	Setting	Description	Default Setting
Pn2C7	0	Home switch input		Same as Pn50A.1	8
	1	Reserved	--	--	0
	2	Reserved	--	--	0
	3	Reserved			0

D.3.2. Extended input signal selection.

These inputs are used in the user program.

Pn2D1	0	Emergency input	0	Same as Pn50A.1	8: ON
	1	New Move Enable	0-F	Same as Pn50A.1	7
	2	Reserved	--	-	0
	3	Reserved	--	--	0

D.4. Output Signal Selections

The following list shows output signal selections and their default settings.

Parameter	Digit Place	Name	Setting	Description	Default Setting
Pn50E	0	/COIN Signal Mapping	0	Disabled.	1: SO1
			1	Outputs from the SO1 (CN1-25, 26) output terminal.	
			2	Outputs from the SO2 (CN1-27, 28) output terminal.	
			3	Outputs from the SO3 (CN1-29, 30) output terminal.	
	1	/V-CMP Signal Mapping	0 to 3	Same as above	1: SO1
	2	/TGON Signal Mapping	0 to 3	Same as above	2: SO2
	3	/S-RDY Signal Mapping	0 to 3	Same as above	3: SO3
Pn50F	0	/CLT Signal Mapping	0 to 3	Same as above	0: Not used
	1	/VLT Signal Mapping	0 to 3	Same as above	
	2	/BK Signal Mapping	0 to 3	Same as above	
	3	/WARN Signal Mapping	0 to 3	Same as above	
Pn510	0	/NEAR Signal Mapping	0 to 3	Same as above	0
	1	Reserved	0 to 3	Same as above	
	2	Not used.	0	—	
	3	Not used.	0	—	
Pn512	0	Output Signal Reversal for SO1 (CN-25 and 26)	0	Output signal is not reversed.	0: Not reversed
			1	Output signal is reversed.	
	1	Output Signal Reversal for SO2 (CN-25 and 26)	0	Output signal is not reversed.	
			1	Output signal is reversed.	
	2	Output Signal Reversal for SO3 (CN-25 and 26)	0	Output signal is not reversed.	
			1	Output signal is reversed.	
3	Not used.	—	—	0	

- Note:**
1. When more than one signal is allocated to the same output circuit, data is output using OR logic.
 2. Depending on the control mode, undetected signals are treated as OFF. For example, in the speed control mode, the /COIN signal is treated as OFF.
 3. Types of /WARN signals: Overload and regenerative overload.

D.4.1. Extended Output Signal Selection

These outputs are used in the user program.

Pn2D2	0	/COIN Signal Mapping	0	Disabled.	0:disable
			1	Outputs from the SO1 (CN1-25, 26) output terminal.	
			2	Outputs from the SO2 (CN1-27, 28) output terminal.	
			3	Outputs from the SO3 (CN1-29, 30) output terminal.	
	1	Not used.	—	—	0
	2	Not used.	—	—	0
	3	Not used.	—	—	0

D.5. Auxiliary Functions

The following list shows the available auxiliary functions.

Parameter	Function
Fn000	Alarm traceback data display.
Fn001	Rigidity setting for online autotuning.
Fn002	JOG mode operation.
Fn003	Zero-point search mode.
Fn004	(Reserved parameter).
Fn005	Parameter settings initialization.
Fn006	Alarm traceback data clear.
Fn007	Writing to EEPROM inertia ratio data obtained from online autotuning.
Fn008	Absolute encoder multi-turn reset and encoder alarm reset.
Fn009	Automatic tuning of analog (speed, torque) reference offset.
Fn00A	Manual adjustment of speed reference offset.
Fn00B	Manual adjustment of torque reference offset.
Fn00C	Manual zero-adjustment of analog monitor output.
Fn00D	Manual adjustment of analog monitor output gain.
Fn00E	Automatic adjustment of motor current detection signal offset.
Fn00F	Manual adjustment of motor current detection signal offset.
Fn010	Write protect setting (protects parameters from being changed).
Fn011	Motor model display.
Fn012	Software version display.
Fn013	Multi-Turn Limit Setting: Change when a Multi-Turn Limit Disagreement Alarm (A.CC) occurs.
Fn014	Clear Option Unit Detection Alarm (A.E7).

D.6. Monitor Modes

The following list shows monitor modes available

Parameter	Content of Display	Unit	Remarks
Un000	Actual motor speed	rpm	—
Un001	Input speed reference	rpm	—
Un002	Internal torque reference	%	Value for rated torque
Un003	Rotation angle 1	pulse	Number of pulses from the origin
Un004	Rotation angle 2	degree	Angle from the origin (electrical angle)
Un005	Input signal monitor	—	—
Un006	Output signal monitor	—	—
Un007	Input reference pulse speed	rpm	—
Un008*	Error counter value	reference units	Amount of position error
Un009	Accumulated load rate	%	Value for the rated torque as 100% Displays effective torque in 10s cycle.
Un00A	Regenerative load rate	%	Value for the processable regenerative power as 100% Displays effective torque in 10s cycle.
Un00B	Power consumed by DB resistance	%	Value for the processable power when dynamic brake is applied as 100% Displays effective torque in 10s cycle.
Un00C	Input reference pulse counter	—	Displayed in hexadecimal.
Un00D	Feedback pulse counter	—	Displayed in hexadecimal.

*Not used in serial communication command.

YET Ltd. ISRAEL

13 Hamelacha St.,
Afeq Industrial Estate
Rosh Ha'ayin 48091
ISRAEL

Tel: +972-3-9004114

Fax: +972-3-9030412

info@yetmotion.com

YET US Inc.

531 King St.,
Unit 1
Littleton, MA 01460
USA

Tel: +1-866-YET-8080

Fax: +1-978-952-6821

USinfo@yetmotion.com

*For more information refer to our web site: **www.yetmotion.com***



Specifications are subject to change without notice due to ongoing product modifications and improvements.

Catalog No. 8U0108

Rev. C